

RELIANCE[™]
P R E C I S I O N





28 AWG WIRES

Precise Motorised
Linear Actuators

305 ±3

1.7 ±0.1



	Introduction to Reliance	i-6
	Linear Actuators	1-1
	Hybrid Linear Actuators	1-26
	Can-Stack Linear Actuators	1-144
	Drives & Controllers	2-001

Section contents

Linear Actuators

Selection Process	Page 1-2
-------------------------	----------

Hybrid Linear Actuators

Product Introduction	Page 1-26
21000 Series	Page 1-30
28000 Series	Page 1-46
35000 Series	Page 1-62
43000 Series	Page 1-86
57000 Series	Page 1-110
87000 Series	Page 1-134
Options For Hybrids	Page 1-142

Can-Stack Linear Actuators

Product Introduction	Page 1-144
19000 Series	Page 1-148
25000 Series	Page 1-156
37000 Series	Page 1-164
15000 Series	Page 1-172
20000 Series	Page 1-180
Z20000 Series	Page 1-186
26000 Series	Page 1-194
Z26000 Series	Page 1-202
26000 Series - High Resolution	Page 1-212
36000 Series	Page 1-220
46000 Series	Page 1-236
Options For Can-Stack	Page 1-246



Selection Process

The following is the minimum information needed to select the most appropriate linear actuator.

1. Linear force needed to move the load, expressed in Newtons (N)
2. Linear distance the load needs to be moved, expressed in meters (m)
3. Time required to move the load, expressed in seconds (s)
4. One of the actuators from tables 1-3 below
5. Performance curves illustrated in the linear actuator section

The power required to meet the application is now calculated using the parameters above. This allows the user to easily choose the correct motor frame-size needed.

$$\text{Power} = \frac{\text{Distance travelled (m)} \times \text{Force (N)}}{\text{Time taken (s)}} = \text{Watts (W)}$$

Once the power is known in watts, choose the most appropriate frame-size from tables below.

All stepper motor linear actuators require a drive to send the pulses to the motor. As seen in the table, the power for both an L/R drive and a chopper drive is listed. Most applications today use an electronic chopper drive. Unless the application is battery powered (as in a hand-held portable device), a chopper drive is highly recommended to get the maximum performance from the linear actuator.

Frame Sizes and Performance Based on Required Output Power

1 Hybrid Single Stack					
				Max. Linear Power (Watts)	
Series	Size	Max Force (N)	Linear Travel Per Step (Micron)	L/R Drive	Chopper Drive
21000	8	44	1.5 - 40	0.3	0.37
28000	11	90	3 - 50	0.27	0.51
35000	14	220	1.5 - 50	0.57	1.5
43000	17	220	1.5 - 50	1.02	2.31
57000	23	890	4 - 50	1.47	6
87000	34	2224	12.7 - 127	N/A	21.19



2 Hybrid Double Stack					
				Max. Linear Power (Watts)	
Series	Size	Max Force (N)	Linear Travel Per Step (Micron)	L/R Drive	Chopper Drive
21000	8	75	2.5 - 40	N/A	0.76
28000	11	133	3 - 50	N/A	1.14
35000	14	220	15.8 - 127	N/A	2.7
43000	17	337	15.8 - 127	N/A	4.62
57000	23	890	12.7 - 127	N/A	10.08

Velocity

After calculating the mechanical power needed to meet the application requirements, the linear velocity in millimeters per second is calculated using the following equation.

$$\text{Velocity linear} = \frac{\text{Required travel distance (mm)}}{\text{Time to achieve travel (s)}} = \text{mm/s}$$

3 Can-Stack					
				Max. Linear Power (Watts)	
Series	Size	Max Force (N)	Linear Travel Per Step (Micron)	L/R Drive	Chopper Drive
G4 19000	20	50	25 - 100	0.17	0.35
G4 25000	26	90	12.7 - 100	0.26	0.53
G4 37000	36	260	12.7 - 100	0.44	0.66
15000	15	7	20	0.025	0.03
20000	20	16	25 - 100	0.05	0.06
Z20000	20	35	25 - 100	0.09	0.23
26000	26	50	6 - 100	0.17	0.18
Z26000	26	80	6 - 100	0.18	0.48
36000	36	160	3 - 100	0.23	0.51
46000	46	260	12.7 - 400	0.55	1.13



Example No1

Application requirements:

Required Force (N) = 66.72 N
 Required Travel (mm) = 76.20 mm
 Time to Achieve Travel (sec) = 6 sec
 Desired Cycles = 1,000,000
 Linear Velocity (mm/sec) = 12.7 mm/sec

Calculate the initial rated force based on required number of cycles:

Refer to Figure 6. and determine the % wear after 1,000,000 cycles.
 This is indicated with the line in Figure 1. below.

Figure 1. Life expectancy. Cycles on a standard stroke actuator

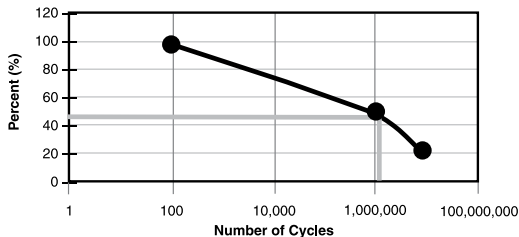

As indicated in the graph, in order to get 1,000,000 cycles, a factor of 50% must be used when sizing the actuator. The initial rated actuator capacity required in order to meet the load after 1,000,000 cycles is therefore:

$$66.72 \text{ N} / 0.5 = 133.44 \text{ N}$$

Choose frame-size of actuator from selector table below:

Determine the required linear mechanical power in watts

$$P_{\text{linear}} = (133\text{N} \times 0.0762\text{m}) / 6 \text{ sec} = 1.7 \text{ Nm} / \text{sec} = 1.7 \text{ watts}$$

Use table 1 to determine the correct frame-size actuator. As discussed earlier, most applications will use a chopper drive to supply the required input pulses to the stepper motor. The 43000 (Size 17 hybrid) was chosen for this application, as highlighted in the "Hybrid Single Stack" section of table 1.

Hybrid Single Stack					
				Max. Linear Power (watts)	
Series	Size	Max Force (N)	Linear Travel Per Step (Micron)	L/R Drive	Chopper Drive
21000	8	44	1.5 - 40	0.3	0.37
28000	11	90	3 - 50	0.27	0.51
35000	14	220	1.5 - 50	0.57	1.5
43000	17	220	1.5 - 50	1.02	2.31
57000	23	890	4 - 50	1.47	6
87000	34	2224	12.7 - 127	N/A	21.19



Select a Suitable Resolution using the “Force vs Linear Velocity” Chart

As determined by the life calculation performed above, an initial load of 66.72N is to be moved at a velocity of 12.7 mm/sec. The resulting leadscrew resolution required in the Size 17 hybrid motor is 0.012192 (J resolution), as indicated in Figure 2 below.

Figure 2. Force vs Linear Velocity Size 17 Series 43000.
5.54mm Ø leadscrew, bipolar, Chopper Drive, 100%, Duty Cycle

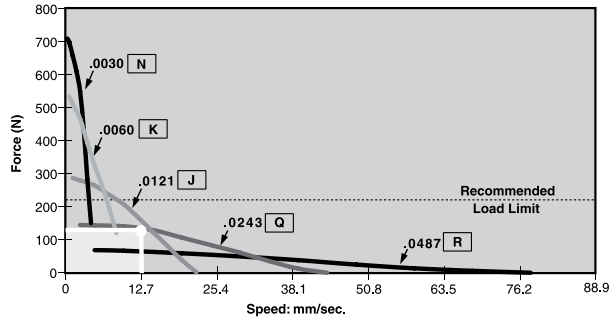

Verify selection by checking force at the required step rate

Earlier in the section, it was discussed that the leadscrew advances based on the number of input steps to the motor. Our performance curves are expressed in both “mm/sec” (Figure 2) and also in “steps/sec” (Figure 3). As an effective check, verify the selection by checking the force at the required step rate.

Resolution chosen	0.012192 mm/step
Required linear velocity	12.7 mm/sec
Required step rate	$(12.7 \text{ mm/sec}) / (0.012192 \text{ mm/step}) = 1041 \text{ steps/sec}$

Figure 3. Force vs Pulse Rate Size 17 Series 43000.
5.54mm Ø leadscrew, bipolar, Chopper Drive, 100%, Duty Cycle

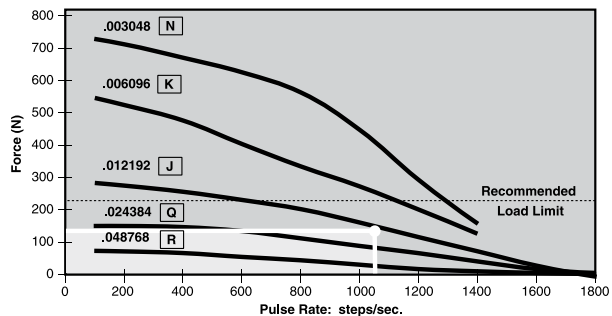

Figures 2. and 3. are a good illustration of how the pulses to the stepper motor translate into linear motion through the leadscrew.



Example No2

We offer a range of Double Stack Hybrid Actuators that are designed to meet the needs of higher speed applications. This next example illustrates a typical situation where higher speed is required to perform the motion.

All other applications requirements with the exception of the move velocity are unchanged from Example 1.

Application requirements:

Required Force (N) =	66.72 N
Required Travel (mm) =	76.20 mm
Time to Achieve Travel (sec) =	3 sec (Modified application requirement)
Desired Cycles =	1,000,000
Linear Velocity (mm/sec) =	25.4 mm/sec (Modified linear velocity)

Calculate the initial rated force based on required number of cycles:

Refer to Figure 6. and determine the % wear after 1,000,000 cycles. This indicated by the line in Figure 1. This initial force required in order to meet the load after 1,000,000 cycles is therefore:

$$66.72 \text{ N} / 0.5 = 133.44 \text{ N}$$

Choose frame-size of actuator from selector table:

Determine the required linear mechanical power in watts

$$P_{\text{linear}} = (133\text{N} \times 0.0762\text{m}) / 3 \text{ sec} = 3.4 \text{ Nm} / \text{sec} = 3.4 \text{ watts}$$

As shown from the result above, the required output power increased by 100% due to the application requirement change from a 6sec Time to Achieve Travel (Example 1) to a 3sec Time to Achieve Travel.

Assuming the mounting footprint is to remain unchanged (in this case, the size 17 motor frame), using the Double Stack version of the actuator would easily meet the application requirements. This is highlighted in the "Hybrid Double Stack" section of the table below.

Hybrid Double Stack					
				Max. Linear Power (watts)	
Series	Size	Max Force (N)	Linear Travel Per Step (Micron)	L/R Drive	Chopper Drive
21000	8	75	2.5 - 40	N/A	0.76
28000	11	133	3 - 50	N/A	1.14
35000	14	220	15.8 - 127	N/A	2.7
43000	17	337	15.8 - 127	N/A	4.62
57000	23	890	12.7 - 127	N/A	10.08



Select a Suitable Resolution using the “Force vs Linear Velocity” Chart

As determined by the life calculation performed above, an initial load of 66.72N is to be moved at a velocity of 25.4mm/sec. The intercept falls under curve “C”. The resulting leadscrew required in the Size 17 Double Stack Hybrid motor is 0.317 (C resolution), as indicated in Figure 4 below.

Figure 4. Force vs Linear Velocity Size 17 Double Stack Series 43000.
6.35mm Ø leadscrew, bipolar, Chopper Drive, 100%, Duty Cycle

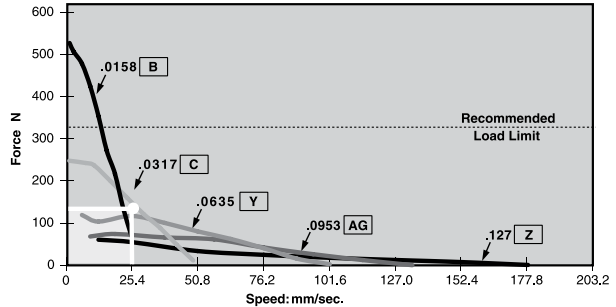

Verify selection by checking force at the required step rate

As discussed earlier, our motor performance curves are expressed in both “mm/sec” and also in “step/sec”. As an effective check, verify the selection by checking the force at the required step rate.

Resolution chosen	0.0317 mm/step
Required linear velocity	25.4 mm/sec
Required step rate	$(25.4 \text{ mm/sec}) / (0.0317 \text{ mm/step}) = 801 \text{ steps/sec}$

The intercept of the required force and pulse rate (load point) is confirmed to fall under curve “C” as calculated.

Figure 5. Force vs Pulse Rate Size 17 Double Stack Series 43000.
6.35mm Ø leadscrew, bipolar, Chopper Drive, 100%, Duty Cycle

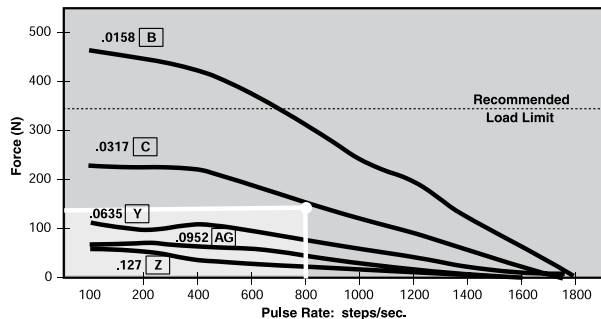



Actuator Life

When all aspects of an application are taken into account, and the selected product is well matched to its duty, our actuators have the potential to deliver up to 20 million cycles. In practice the life of an actuator is determined by the demands placed upon it by the specific application. To determine an actuators performance in a given system and design for maximum life, the system must be thoroughly understood. We recommend testing in the final assembly using field conditions to be the optimum method for obtaining dependable rating data. Clearly this is not always possible, and the extent to which a rating is an estimate should be kept in mind when selecting a product.

A stepper motor is a brushless design, with the bearings being the only components subject to mechanical wear. Together with the lead screw interface with the nut (linear actuators), these are the only areas which suffer with accumulating duty. Local load at these points, together with operating environment are the factors which affect this rate of degradation.

Extensive field experience has shown that increased loading such as side loads or unbalanced set-up, and harsh environmental factors such as high humidity, harsh chemicals, excessive dirt or debris and raised temperature, can significantly affect life expectancy.

To help reduce the negative effects of poor operating conditions, we recommend the use of techniques to improve heat dissipation such as effective air flow and heat sink capacity, and careful consideration of the environment in which the system operates.

The best way to predict life is through application testing. However, we can estimate the value. A stepper motor contains no brushes to wear out and also utilizes precision long-life ball bearings so the main wear component is the power nut. The number of cycles can be summarised as a function of load, as illustrated in Figure 6 below.

Figure 6. % Rated Load vs Number of Cycles. Cycles on a standard stroke actuator.

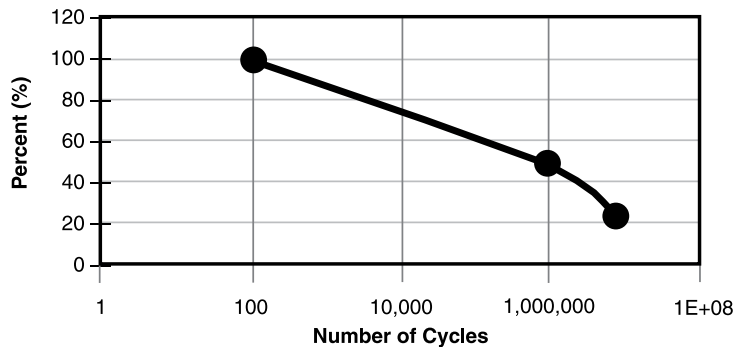



Our linear actuators are capable of up to 20 million cycles and our rotary motors provide up to 25000 hours of service. Resultant life is determined by each customer's unique application. The following definitions are important for understanding motor life and fatigue.

Continuous Duty: Operating a stepper motor at its rated voltage at all time.

25% Duty Cycle: Running a motor double its rated power. The motor is "on" approximately 25% of the time. The motor generates about 60% more output than at rated voltage. Note, duty cycle is not related to the load placed on the motor.

Life: A linear actuators life is the number of cycles that the motor is able to move at a prescribed load and maintain step accuracy. Rotary motor life is the number of hours of operations.

One Cycle: A linear actuator's cycle consists of extending and retracting back to the original position.

Force vs Linear Velocity Curves

Once the required actuator frame-size is determined and linear velocity is calculated, the "force vs linear velocity curve" is used to determine the most suitable resolution of the actuator leadscrew.

Figure 7. Force vs Linear Velocity Size 17 Series 43000. (5.54 mm Ø leadscrew, Bipolar, Chopper Drive, 100% Duty Cycle

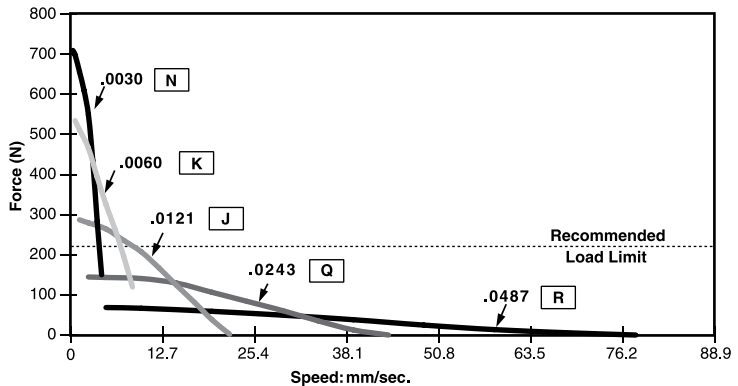



Resolution, Accuracy and Repeatability

Resolution:

This is defined as the nominal incremental distance an actuators output shaft will extend with each input pulse. Resolution is expressed as seen in the curves above, resolutions are available in very small increments per step allowing very controlled linear motion.

$$\text{Resolution} = (\text{screw lead}) / (360 \text{ deg} / \text{step angle})$$

$$\text{Actuator Resolution} = (2.4384 \text{ mm/rev}) / (360\text{deg}/(1.8\text{deg}/\text{step})) = 2.4384/200 = 0.0122 \text{ mm/step}$$

Accuracy:

The difference between the theoretical distance and the actual distance traveled. Due to manufacturing tolerances in the individual components of the actuator, the actual travel will be slightly different. The tight design tolerances within our actuators allow this error to be very small, but nevertheless, it exists. See figure 8.

Generally an actuator moving though 25.4 mm will achieve the desired position to a tolerance of +/- 0.0127 mm.

Figure 8. Accuracy and repeatability

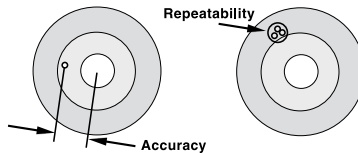

Repeatability:

The range of positions attained when the actuator is commanded to approach the same target multiple time under identical conditions.

Example:

Allow the actuator to extend a commanded distance from its home position(starting point). Measure and record this distance and call it "X". Retract the actuator back to its home position. Command the actuator to repeatedly return to the commanded distance "X". The differences between the actual distances traveled and "X" is the repeatability.

Resonance

Stepper motors have a natural resonant frequency as a result of the motor being a spring-mass system. When the step rate equals the motor's natural frequency, there may be an audible change in noise made by the motor, as well as an increase in vibration. The resonant point will vary with the application and load, but typically occurs somewhere between 100 and 250 steps per second. In severe cases the motor may lose steps at the resonant frequency. Changing the step rate is the simplest means of avoiding many problems related to resonance in a system. Also, half stepping or micro stepping usually reduces resonance problems. When accelerating or decelerating to a given speed, the resonance zone should be passed through as quickly as possible.



Selecting the Optimum Motor

In order to select the best motor several factors must be considered. Is linear or rotary motion required? The following list will help determine the best choice of an actuator or a rotary motor.

Rotary Motor

- How much torque required?
- What is the duty cycle?
- What is desired step angle?
- What is the step rate of RPM?
- Bipolar or unipolar coils?
- Coil Voltage?
- Detent or holding torque requirements?
- Are there size restrictions?
- What is anticipated life requirements?
- Temperature of operating environment?
- Sleeve or ball bearings?
- Radial and axial load?
- Type of driver?

Linear Actuator

- How much force is required?
- What is the duty cycle?
- What is desired step increment?
- What is the step rate or speed of travel?
- Bipolar or unipolar coils?
- Coil Voltage?
- Must the screw hold position with power off or must it be "Backdriveable" with power off?
- Are there size restrictions?
- What is anticipated life requirement?
- Temperature of operating environment?
- Captive or non-captive shaft?
- Type of driver?

Drives

Stepper motors require some external electrical components in order to run. These components typically include a power supply, logic sequencer, switching components and a clock pulse source to determine the step rate. Many commercially available drives have integrated these components into a complete package. Some basic drive units have only the final power stage without the controller electronics to generate the appropriate step sequencing.

Bipolar Drives

This is a very popular drive for a two phase bipolar motor having four leads. In a complete driver/controller the electronics alternately reverse the current in each phase. The stepping sequence is shown in figure 5.

Unipolar Drives

This drive requires a motor with a center-tap at each phase (6 leads). Instead of reversing the current in each phase, the drive only has to switch current from one coil to the other in each phase (figure 6). The windings are such that this switching reverses the magnetic fields within the motor. This option makes for a simpler drive but only half of the copper winding is used at any one time. This results in approximately 30% less available torque in a rotary motor or force in a linear actuator as compared to an equivalent bipolar motor.



L/R Drives

This type of drive is also referred to as a constant voltage drive. Many of these drives can be configured to run bipolar or unipolar stepper motors. L/R stands for the electrical relationship of inductance (L) to resistance (R). Motor coil impedance vs. step rate is determined by these parameters. The L/R drive should “match” the power supply output voltage to the motor coil volt-age rating for continuous duty operation. Most published motor performance curves are based on full rated voltage applied at the motor leads. Power supply output voltage level must be set high enough to account for electrical drops within the drive circuitry for optimum continuous operation.

Performance levels of most steppers can be improved by increasing the applied voltage for shortened duty cycles. This is typically referred to as “over-driving” the motor. When over-driving a motor, the operating cycle must have sufficient periodic off time (no power applied) to prevent the motor temperature rise from exceeding the published specification.

Chopper Drives

A chopper drive allows a stepper motor to maintain greater torque or force at higher speeds than with an L/R drive. The chopper drive is a constant current drive and is almost always the bipolar type. The chopper gets its name from the technique of rapidly turning the output power on and off (chopping) to control motor current. For this setup, low impedance motor coils and the maximum voltage power supply that can be used with the drive will deliver the best performance. As a general rule, to achieve optimum performance, the recommended ratio between power supply and rated motor voltage is eight to one. An eight to one ratio was used for the performance curves in this catalogue.

Microstepping Drives

Many bipolar drives offer a feature called microstepping. Microstepping electronically divides a full step into smaller steps. For instance, if one step of a linear actuator is 0.0254 mm, this can be driven to have 10 microsteps per step. In this case, one microstep would normally be 0.00254 mm. Microstepping effectively reduces the step increment of a motor. However, the accuracy of each microstep has a larger percentage of error as compared to the accuracy of a full step. As with full steps, the incremental errors of microsteps are non-cumulative.

Summary

Stepper motors have been used in a wide array of applications for many years. With trends towards miniaturization, computer control and cost reduction, “hybrid” style stepper motor actuators are being used in an ever increasing range of applications, in particular the use of linear actuators. These precise, reliable motors can be found in many applications including blood analysers and other medical instrumentation, automated stage lighting, imaging equipment, HVAC equipment, value control, printing equipment, X-Y tables, integrated chip manufacturing, inspection and test equipment. This attractive technical solution eliminates the use of numerous components and the associated costs related to assembly, purchasing, inventory, etc. The applications for these motors are only limited by the designer’s imagination.



Terminology

Detent or residual torque: The torque required to rotate the motor output shaft with no current applied to the windings.

Drives: A term describing the external electrical components to run a stepper motor system. This will include power supplies, long sequencers, switching components and usually a variable frequency pulse source to determine the step rate.

Dynamic torque: The torque generated by the motor at a given step rate. Dynamic torque can be represented by PULL in torque or PULL OUT torque.

Holding torque: The torque required to rotate the motor's output shaft while the windings are energised in a steady state.

Inertia: The measure of a body's resistance to acceleration or deceleration. Typically used in reference to the inertia of the load to be moved by the motor or the inertia of a motor's rotor.

Linear step increment: The linear travel movement generated by the leadscrew with each single step of the rotor.

Maximum temperature rise: Allowable increase in motor temperature by design. Motor temperature rise is caused by the internal power dissipation of the motor as a function of load. This power dissipation is the sum total from I^2R (copper loss), iron (core) loss and friction. The final motor temperature is the sum of the temperature rise and ambient temperature.

Pulse rate: The number of pulses per second (pps) applied to the windings of the motor. The pulse rate is equivalent to the motor step rate.

Pulses per second (PPS): The number of steps that the motor takes in one second (sometimes called "steps per second"). This is determined by the frequency of pulses produced by the motor drive.

Ramping: A drive technique to accelerate a given load from a low step rate, to a given maximum step rate and then decelerate to the initial step rate without loss of steps.

Single step response: The time required for the motor to make one complete step.

Step: The angular rotation produced by the rotor each time the motor receives a pulse. For linear actuators a step translates to a specific linear distance.

Step angle: The rotation of the rotor caused by each step, measured in degrees.

Step per revolution: The total number of steps required for the rotor to rotate 360° .

Torque: The sum of the frictional load torque and inertial torque.

Pull out torque: The maximum torque the motor can deliver once the motor is running at constant speed. Since there is no change in speed there is no inertial torque. Also, the kinetic energy stored in the rotor and load inertia help to increase the pull out torque.

Pull in torque: The torque required to accelerate the rotor inertia and any rigidly attached external load up to speed plus whatever friction torque must be overcome. Pull in torque, therefore, is always less than pull out torque.

Torque to inertia ratio: Holding torque divided by inertia.



How a Stepper Motor Driven Actuator Works

One of the most energy efficient and compact ways to convert rotary to linear motion is within the motor itself. Our range of stepper motor driven linear actuators use a threaded precision nut which is rotated by the motor. The shaft is replaced by a lead screw which passes through and engages with the nut. Hence the motive force which rotates the nut generates a corresponding linear motion of the lead screw. This approach can greatly simplify the design of linear motion solutions, while using a thoroughly understood and economic technology. The use of stepper motors also means high resolution and accuracy can be achieved where precision motion is required, as the individual rotary steps of the motor deliver corresponding linear steps of the lead screw.

Stepper motors offer the unique ability to move a given amount of rotary motion for every electrical input pulse. Depending on the type, our motors achieve resolutions from 18 degrees per step, to 0.9 degrees per step. The stepping feature, coupled with the characteristics of the lead screw, provides a broad range of fine positioning solutions.

Permanent magnet stepper motors incorporate a permanent magnet rotor, coil windings, and a steel stator capable of carrying magnetic flux. Energising a coil winding creates an electromagnetic field with a NORTH and SOUTH pole as shown in figure 9.

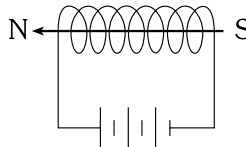

Figure 9. Magnetic field created by energising a coil winding

The stator concentrates the magnetic field and causes the permanent magnet rotor to align itself to the field. The stator magnetic field can be altered by sequentially energising and de-energising a sequence of different stator coils. This causes a “stepping” action and incrementally moves the rotor resulting in angular motion.

Assembly Details

Figure 10. below is a cross section drawing of a “captive (C)” type linear actuator. Captive indicates that there is already an anti-rotation mechanism built into the actuator though the use of a splined “anti-rotation” shaft and a “captive sleeve”. Other forms of linear actuators are “Non-captive (NC)” and “External Linear (EL)” as pictured in Figure 11 and 12.

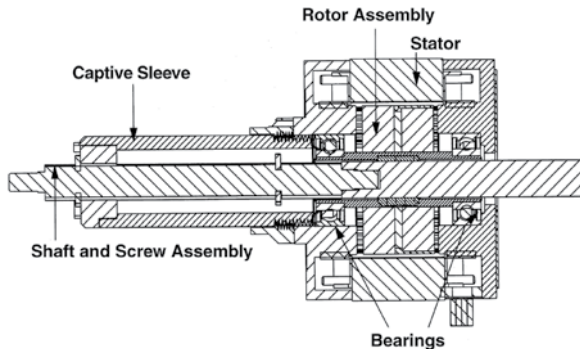

Figure 10. Typical Hybrid Linear Actuator. Captive linear stepping actuator.

Actuators



Figure 11. Hybrid Linear Actuators
Size 17 Series. (43mm square)
Captive, Non-captive and External Linear, available in 1.8 and 0.9 rotational degrees per step.



Figure 12. Can-Stack Linear Actuators.
19000 Series (20 mm)
Captive, Non-captive and External Linear, available in 15 and 7.5 rotational degrees per step.



Hybrid Linear Actuators

Series	Size (Square)	Configuration	Stroke mm		Max Force (N)	Travel Per Step (micron)
			C#	NC/ EL#		
21000	21 mm	C / NC / EL	9 - 38. 1	Up to ≈ 200	2 - 44	1.5 - 40
28000	28 mm	C / NC / EL	12.7 - 63.5	Up to ≈ 250	15 - 90	3 - 50
35000	35 mm	C / NC / EL	12.7 - 63.5	Up to ≈ 300	50 - 220	1.5 - 50
43000	43 mm	C / NC / EL	12.7 - 63.5	Up to ≈ 400	100 - 220	1.5 - 50
57000	57 mm	C / NC / EL	12.7 - 63.5	Up to ≈ 500	300 - 890	4 - 50
87000	87 mm	C / NC / EL	12.7 - 63.5	Up to ≈ 500	400 - 2224	12.7 - 127

Double Stack Hybrid Linear Actuators

Series	Size (Square)	Configuration	Stroke mm		Max Force (N)	Travel Per Step (micron)
			C#	NC/ EL#		
21000	21 mm	C / NC / EL	9 - 38. 1	Up to ≈ 200	10 - 75	2.5 - 40
28000	28 mm	C / NC / EL	12.7 - 63.5	Up to ≈ 250	30 - 133 ^A	3 - 50
35000	35 mm	C / NC / EL	12.7 - 63.5	Up to ≈ 300	50 - 220 ^A	15.8 - 127
43000	43 mm	C / NC / EL	12.7 - 63.5	Up to ≈ 400	50 - 337	15.8 - 127
57000	57 mm	C / NC / EL	12.7 - 63.5	Up to ≈ 500	150 - 890 ^A	12.7 - 127

^AMaximum force limited by bearing capabilities



Can-Stack Linear Actuators

Series	Ø Size	Configuration	Stroke mm		Max Force (N)	Travel Per Step (micron)
			C#	NC/ EL#		
G4 19000	20 mm	C / NC / EL	14 - 31	Up to ≈ 150	12 - 50	25 - 100
G4 25000	26 mm	C / NC / EL	13 - 31	Up to ≈ 150	20 - 90	12.7 - 100
G4 37000	36 mm	C / NC / EL	17 - 38	Up to ≈ 150	30 - 260	12.7 - 100
LC15	15 mm	C / EL	12.7	Up to ≈ 60	7	20
(Z)20000	20 mm	C / NC / EL	12.7	Up to ≈ 150	3 - 35	25 - 100
(Z)26000	26 mm	C / NC / EL	12.7 - 31	Up to ≈ 150	10 - 80	6 - 100
36000	36 mm	C / NC / EL	15.5	Up to ≈ 150	15 - 160	3 - 100
46000	46 mm	C / NC / EL	23.1	Up to ≈ 200	20 - 260	12.7 - 400

* Configurations = Captive (C) / Non-captive (NC) / External Linear (EL) Leadscrews

Drives

	Type	Motor Leads	Input Voltage (VDC)	Current (RMS)/Phase (I)	Microstepping Resolution
40105	Chopper	4	20 - 40	2	2
44103	Chopper	4*	24 - 28	1	8
DCS4020	Chopper	4	24 - 40	2	2
DCM4826X	Chopper	4	12 - 48	2.6	64
DCM8028	Chopper	4 / 6 / 8	20 - 80 E	2.8	256
DCM8055	Chopper	4 / 6 / 8	20 - 80 E	5.5	256

* 5V motors only. E = For Europe - the max. Input voltage must be limited to 70 VDC (CE regulations).

Drives

Series	Type	Input Voltage (VDC)	Programming	Connector	I/O inputs - I/O outputs
IDEA Drive	Chopper	12 - 75 VDC	Graphic User Interface	USB/RS-485	8 opto-isolated



Nuts made from Engineered Polymers

Many lead screw nuts in this catalogue feature high strength self-lubricating polymers, where compounds within the material interact with the surface of the screw to offer lubrication over the lifetime of the product. The coefficient of friction and hence wear life and drive torque required to rotate the lead screw, are governed by the consistent delivery of sufficient lubricant to the screw/nut interface by the engineered plastic from which the nut is made. Consistent friction avoids erratic drag torque, unpredictable wear, and ultimately premature failure.

Screw Coatings

The following screw coatings have been carefully chosen to complement the properties of the nut material, improving or adding to the even coating of lubricant to improve life expectancy in the most demanding applications.

Tetrafluoroethylene (TFE) Screw Coatings

Kerkote is a long term dry lubricant optimised for use with softer plastics such as acetals and nylons, with or without mechanical reinforcement. Lubrication at the screw/nut interface occurs by the nut picking up Kerkote TFE material from the coating, in addition to the internal lubricant within the plastic nut. Transfer of TFE to the nut continues throughout the life of the assembly so long as the nut periodically travels over areas with the coating, which also has a beneficial tendency to migrate along the length of the screw. Screws lubricated with Kerkote TFE should not be additionally lubricated, or used in environments contaminated by oils or other lubricants.

Black Ice TFE coating is a hard coating suitable for all environments with virtually any type of polymer lead screw nut. It is not intended for use with glass fibre reinforced, or metal nuts. The Black Ice TFE is bonded to the surface of the leadscrew to enhance abrasion performance with contamination, in rigid polymer systems and applications where fluid wash down systems are used.





Greases

We offer a selection of greases designed to meet almost any application. Please contact us for assistance in selecting the most suitable lubrication option for your application.

	Grease Type	Chemical Compatibility	Temperature	Load Carrying Capacity	Comments	Cost Comparison
HSS-17	Synthetic Hydro-carbon	Good	-20°C to +125°C	High	Standard	£
HSS-06	Perfluoropolyether	Best	-65°C to +250°C	Moderate	Tough Environments	££
HSS-16	Perfluoropolyether	Better	-80°C to +204°C	Moderate	Vacuum Compatible	£££
HSS-20	Perfluoropolyether	Best	-65°C to +250°C	Moderate	High Repeatability	£££

HSS-17

Is a medium viscosity synthetic hydrocarbon grease thickened with lithium soap. It is fortified with EP (extreme pressure) modifiers to increase load carrying capabilities and TFE to increase lubricity and reduce friction. Rated temperature capability is -20°C to +125°C.

HSS-06

Is a TFE thickened heavy viscosity perfluoropolyether grease. It is designed to operate in chemically harsh environments and provides excellent operating properties for light to medium loads. Rated temperature capability is -65°C to +250°C.

HSS-16

Is a perfluoropolyether grease developed for use in vacuum environments. Rated temperature capacity is -80°C to +204°C. Also suitable for low out gassing environments.

HSS-20

Is an ultrafiltered version of HSS-06, meaning that the grease is put through a 'cleaning' process to remove any particles greater than 35 microns in size. It is designed for use when accuracy and repeatability are critical.



“One Phase On” Stepping Sequence

Figure 13 illustrates a typical step sequence for a simplified 2 phase motor. In step 1, phase A of the 2 phase stator is energized. This magnetically locks the rotor in the position shown, since opposite poles attract. When phase A is turned off and phase B is turned on, the rotor moves 90° clockwise. In step 3, phase B is turned off and phase A is turned on but with the polarity reversed from step 1. This causes another 90° rotation. In step 4, phase A is turned off and phase B is turned on, with polarity reversed from step 2. Repeating this sequence causes the rotor to move clockwise in 90° steps.

Figure 13. “One Phase On” stepping sequence for two phase motor “Two Phase On” Stepping sequence

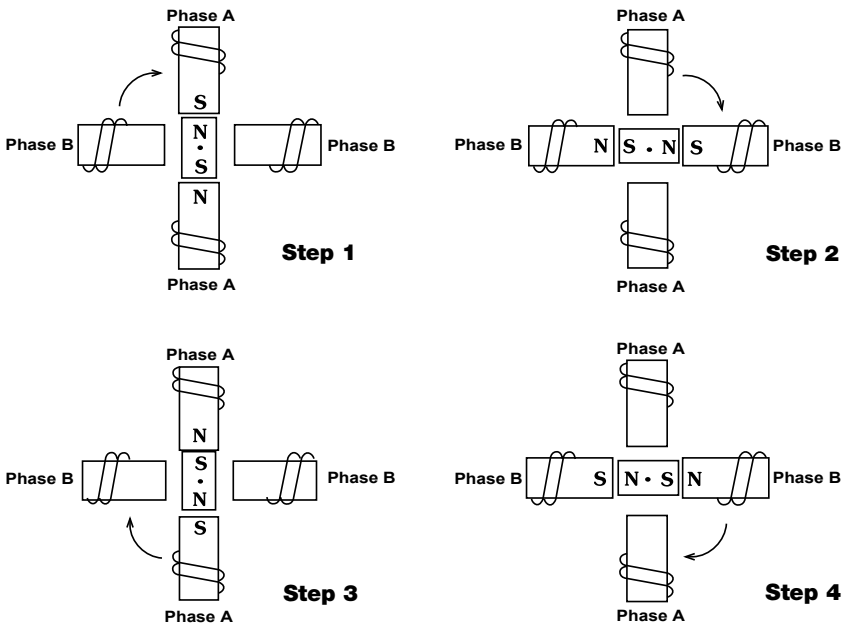

Actuators



“Two Phase On” Stepping Sequence

A more common method of stepping is “two phase on” where both phases of the motor are always energized. However, only the polarity of one phase is switched at a time, as shown in Figure 14. With two phase on stepping, the rotor aligns itself between the “average” north and “average” south magnetic poles. Since both phases are always on, this method provides 41.4% more torque than “one phase on” stepping.

Figure 14. “Two Phase On” stepping sequence for two phase motor

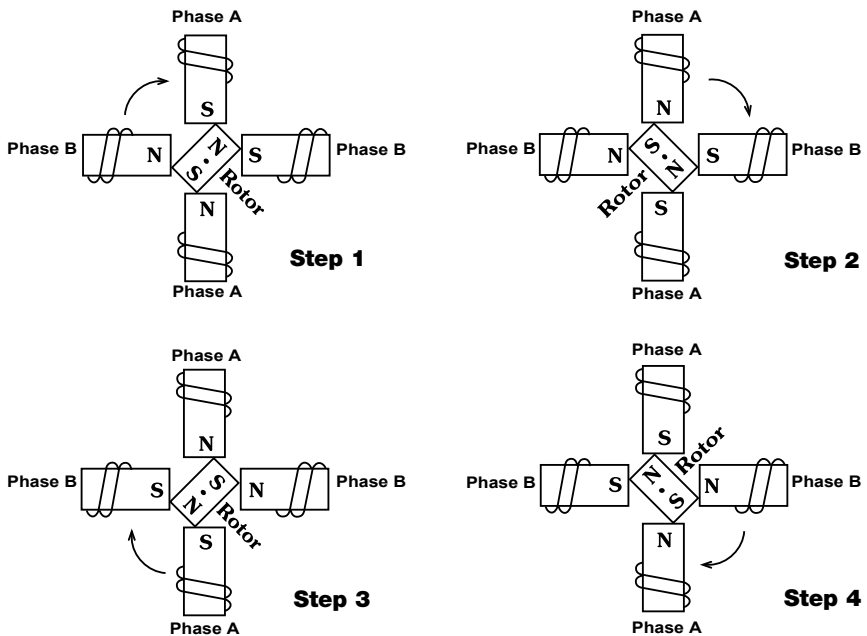



Leadscrew

The acme leadscrew develops a linear force using the simple mechanical principle of the inclined plane. Imagine a steel shaft with a ramp (inclined plane) wrapped around it. The mechanical advantage is determined by the angle of the ramp which is a function of the lead, pitch and diameter of the screw.

Lead – The axial distance a screw thread advances in a single revolution

Pitch – The axial distance measured between adjacent thread forms

The threads of the leadscrew allow a small rotational force to translate into a large load capability depending on the steepness of the ramp (the thread lead). A small lead will provide a high force and resolution output. A large lead will provide a lower force, but a correspondingly higher linear speed from the same source of rotary power.



Examples of different thread configurations: Finer lead threads will provide higher force but lower speeds; Coarse lead threads will provide higher speeds but lower force.

Actuators

Integrated Nut

Every leadscrew is paired with a suitable nut. This nut is often embedded in the rotor of a stepping motor, which makes this actuator configuration unique from other rotary to linear techniques. The traditional nut material is a bearing grade bronze which lends itself to the required machining of the internal threads. Bronze is a traditional compromise between physical stability and lubricity.

A much better material for a power nut in the linear actuator is a lubricated thermoplastic material. With the evolution of new engineered plastics, the screw threads may now travel with a lower overall coefficient of friction. This is illustrated below in Figure 15.

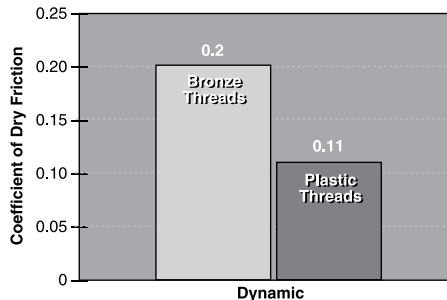

Figure 15. Friction Effects. Comparative friction effects of stainless steel on select rotor materials.



Thermal Considerations

Given the data, it was clear that a plastic drive nut provides the lower coefficient of friction when compared with bronze. Unfortunately, as good as the plastic is for threads, it is not stable enough for the bearing journals of a hybrid motor, which are critical in the hybrid motor design. Under a continuous full load condition, plastic bearing journals can expand as much as 0.102 mm, where brass will expand only 0.025 mm. This is illustrated in Figure 16. In order to achieve the high performance characteristics of the stepper motor, the design must maintain a stator to rotor airgap of only a few thousandths of a millimeter. This tight design requirement demands thermally stable bearing journals.

Figure 16. Thermal Effects. Linear thermal expansion for 25.4 mm samples.

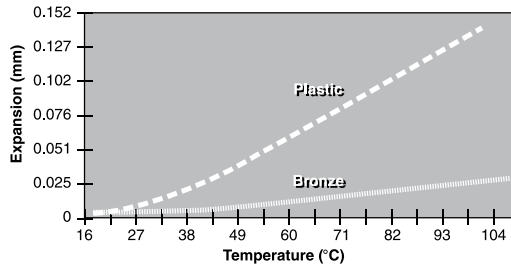

By injection molding plastic threads within a brass rotor assembly, both characteristics of low friction and high bearing journal stability is achieved. This is illustrated in Figure 17 below.

Figure 17. Power Nut Configuration. Embedded in permanent magnet rotor.

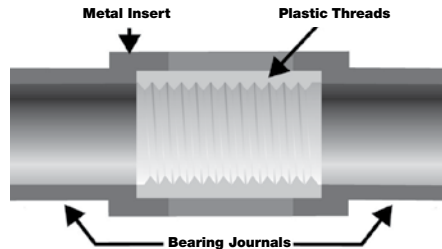

Effects on Actuator Life

The result is a product with quiet operation, higher efficiencies, and higher life expectancies. Motor life is improved by 10 to 100 times over the traditional bronze nut configuration, as illustrated in the life test chart in Figure 18.

Figure 18. Life test: Bronze vs Plastic. Nut used in Size 17 and 23 Hybrid Linear Actuators.

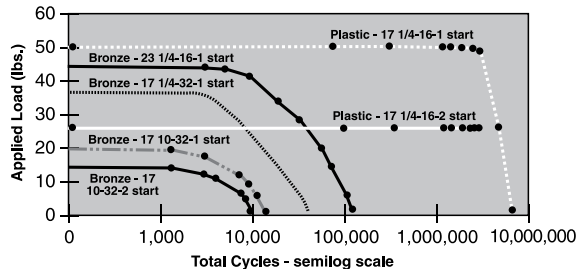



All dimensions in mm

Cross Drilled Hole

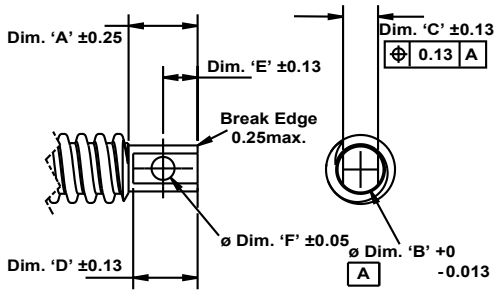

Standard Break Edge

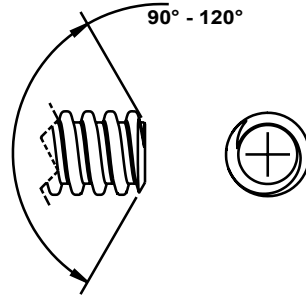

Male Thread

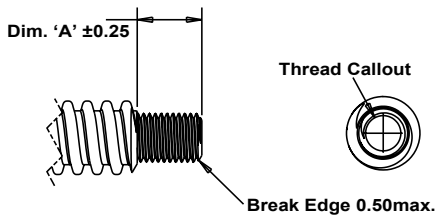

Female Thread

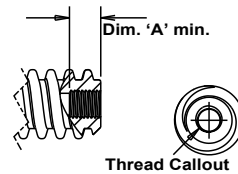

Screwdriver Slot

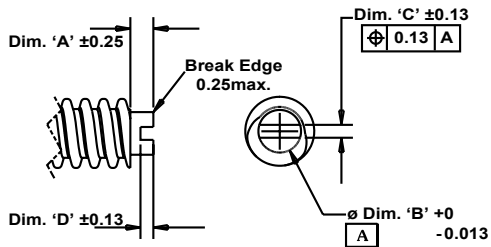

Actuators



All dimensions in mm

Turned Journal

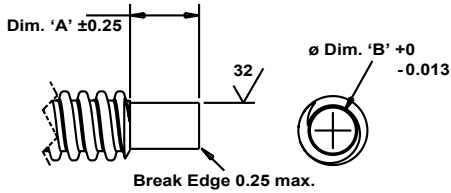

Hex Drive End

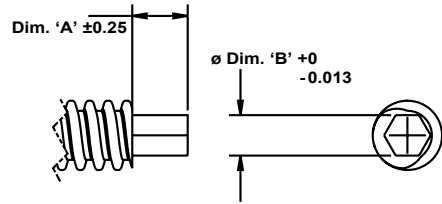

Square End

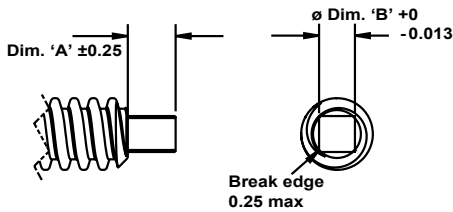

Single Flat

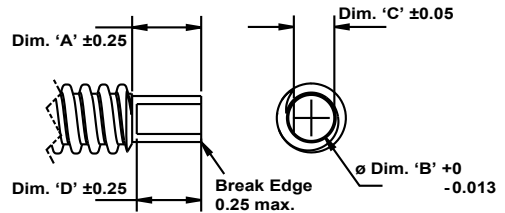

Double Flat

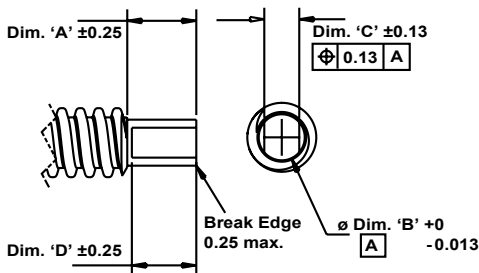

Ground Journal

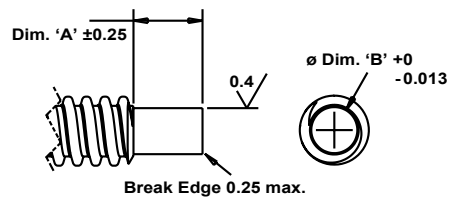

Actuators



Actuators



Quiet, efficient & durable

Our hybrid linear actuators offer high performance and exceptional endurance to the equipment designer, mounted in a compact package. Engineering plastics are incorporated in the rotor drive nut, running on a stainless steel lead-screw. This material combination generates less noise and offers a lower coefficient of friction than the v-thread with bronze nut combination commonly used in other actuators. Life expectancy is significantly increased over the traditional bronze nut, with no maintenance and no price increase, and while bearing pre-load can be selected at manufacture, it does not protrude outboard of the motor profile.

The range covers six square frame sizes, from 21mm to 87mm with each size having three design formats available – captive, non-captive and external linear versions. We offer a series of Double Stack actuators which offer increased torque capability for each frame size, available in sizes from 21mm to 57mm. An integrated and programmable IDEA Drive is available for the size 17 (43mm) hybrid and Double Stack hybrid motors.

The combinations of motor step size and screw lead available mean we can offer a choice of 28 different travel distances per step, from 0.001524mm to 0.127mm. Micro-stepping can be used for even finer resolution and performance optimisation. This accuracy and resolution can be used to control a large payload – our 87mm actuator delivers up to 2224N of linear force.

Typical applications include X-Y tables, medical equipment, semi-conductor handling, telecommunications equipment, valve control and many other uses. We offer specialist motion control design solutions incorporating our standard product range as well as bespoke designs, and our Engineers have extensive experience in the innovative application of our products.



Medical Equipment



Pharmaceuticals



Part number structure

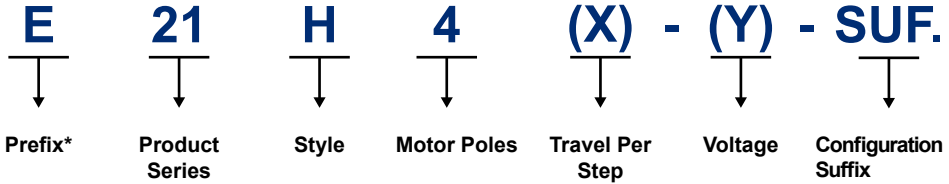

*(Only when using the following)

- E** = External Linear
- P** = Proximity Sensor
- S** = Home Switch
- T** = High Temperature
- K** = Kerk thread form/ nut
- _** = None of the above

- Available Hybrids
- 21000**
 - 28000**
 - 35000**
 - 43000**
 - 57000**
 - 87000**

- F** = 1.8° Non-captive
- H** = 1.8° Captive
- H** = 1.8° Captive (Use "E" prefix for External)
- J** = 0.9° Non-captive
- K** = 0.9° Captive
- K** = 0.9° Captive (Use "E" prefix for External)
- L** = 1.8° Double Stack Non-captive
- M** = 1.8° Double Stack Captive
- M** = 1.8° Double Stack Captive (Use "E" prefix for external)

- 4** = Bipolar (4 Wire)
- 6** = Unipolar (6 Wire)
- G** = IDEA Drive (Size 17 (43000 Series) only)

See 'Travel Selection' table on product page

See 'nomenclature' table on product page.

- Select a 3 figure suffix to suit the application.
- See 'Configuration' table.
- 900 = External Linear with grease nut
- XXX = proprietary configuration assigned to a specific customer application. The identifier can apply to either a standard or custom part.

Actuators



Wiring

Bipolar

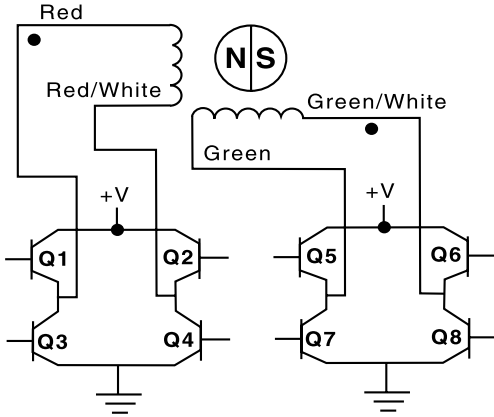

Unipolar

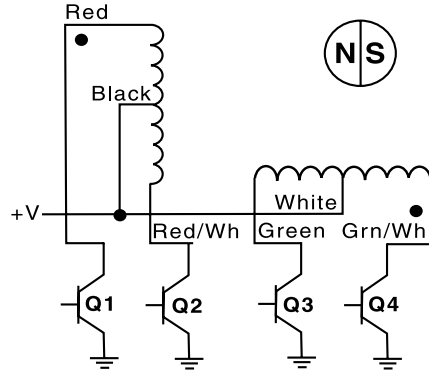

Stepping Sequence

Bipolar	Q2-Q3	Q1-Q4	Q6-Q7	Q5-Q8
Unipolar	Q1	Q2	Q3	Q4
Step				
1	ON	OFF	ON	OFF
2	OFF	ON	ON	OFF
3	OFF	ON	OFF	ON
4	ON	OFF	OFF	ON
1	ON	OFF	ON	OFF

EXTEND CW → ← RETRACT CW

NOTE: Half stepping is accomplished by inserting an off state between transitioning phases.



All dimensions in mm

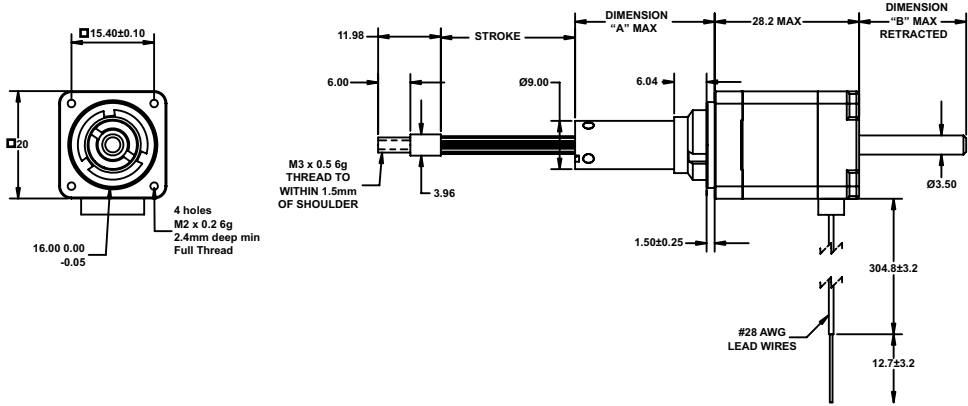

Actuators

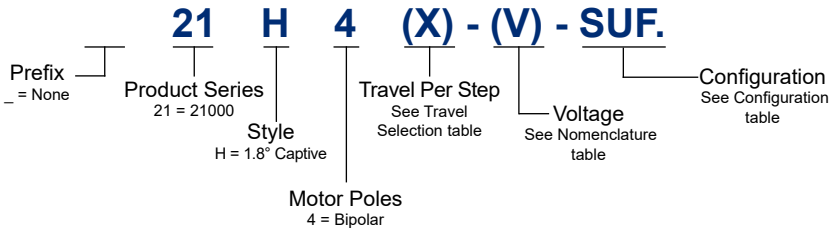

Technical Support

- Selection Guide : Page 1-01
- Product Overview : Page 1-26
- Performance curves : Page 1-36



Nomenclature

Size 8: 21 mm Hybrid Linear Actuator (1.8° Step Angle)				
Part No.	Captive (H)	21H4(X)-(V)-SUF.		
Wiring		Bipolar (4 poles)		
Winding Voltage (V)	2.5 VDC	5 VDC	7.5 VDC	
Current (RMS) each phase	0.49 A	0.24 A	0.16 A	
Resistance each phase	5.1 Ω	20.4 Ω	45.9 Ω	
Inductance each phase	1.5 mH	5.0 mH	11.7 mH	

Motor Specification

Size 8: 21 mm Hybrid Linear Actuator (1.8° Step Angle)	
Power consumption	2.45 W Total
Rotor Inertia	1.4 gcm ²
Insulation Class	Class B (Class F available)
Weight	43g
Insulation Resistance	20MΩ

Standard motors are Class B rated for maximum temperature of 130°C.

Rating modifiers may be necessary when using the shaft fully extended or fully retracted for the whole life cycle.

*Values truncated

Travel Selection

Linear Travel/ Step	0.0015*	0.0025	0.0030*	0.005	0.006*	0.01	0.0121*	0.02	0.04
Screw Ø3.56 mm									
Part No (X)	U	AA	N	AB	K	AC	J	AD	AE

Configuration

Stroke	Dim. "A"	Dim. "B"	SUF.
9.0	11.10	1.58	-904
12.7	14.81	5.28	-905
19.05	21.16	11.63	-907
25.4	27.51	17.98	-910
31.8	33.86	24.33	-912
38.1	40.21	30.68	-915

Further resolutions available on request.

Custom leadscrew lengths are available on request.



All dimensions in mm

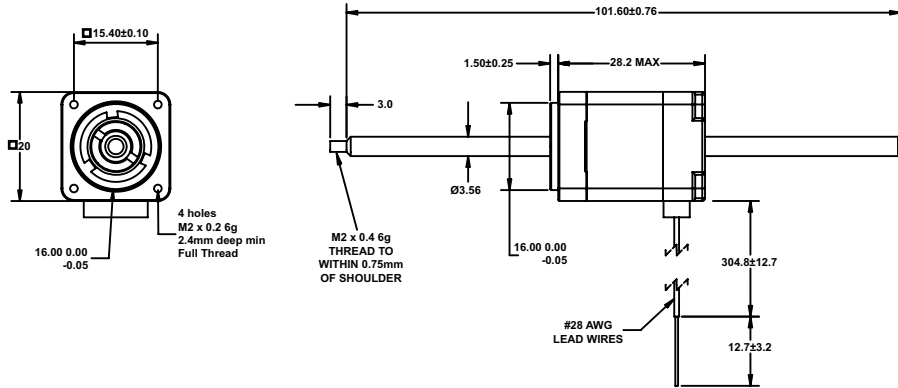

Actuators

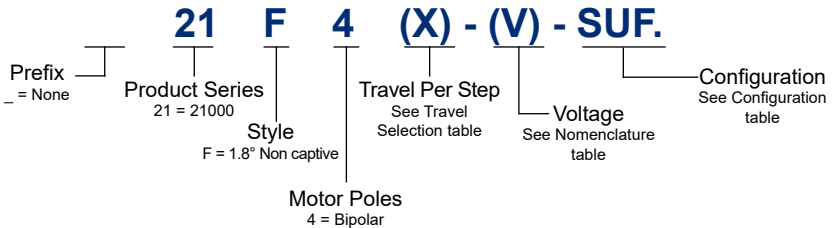

Technical Support

- Selection Guide : Page 1-01
- Product Overview : Page 1-26
- Performance curves : Page 1-36



Nomenclature

Size 8: 21 mm Hybrid Linear Actuator (1.8° Step Angle)				
Part No.	Non-captive (F)	21F4(X)-(V)-SUF.		
Wiring		Bipolar (4)		
Winding Voltage (V)	2.5 VDC	5 VDC	7.5 VDC	
Current (RMS)/phase	0.49 A	0.24 A	0.16 A	
Resistance/phase	5.1 Ω	20.4 Ω	45.9 Ω	
Inductance/phase	1.5 mH	5.0 mH	11.7 mH	

Motor Specification

Size 8: 21 mm Hybrid Linear Actuator (1.8° Step Angle)	
Power consumption	2.45 W Total
Rotor Inertia	1.4 gcm ²
Insulation Class	Class B (Class F available)
Weight	43g
Insulation Resistance	20MΩ

Standard motors are Class B rated for maximum temperature of 130°C.

Rating modifiers may be necessary when using the shaft fully extended or fully retracted for the whole life cycle.

*Values truncated

Travel Selection

Linear Travel/ Step	0.0015*	0.0025	0.0030*	0.005	0.006*	0.01	0.0121*	0.02	0.04
Screw Ø3.56 mm									
Part No (X)	U	AA	N	AB	K	AC	J	AD	AE

Configuration

Further resolutions available on request.

Custom leadscrew lengths are available on request.



All dimensions in mm

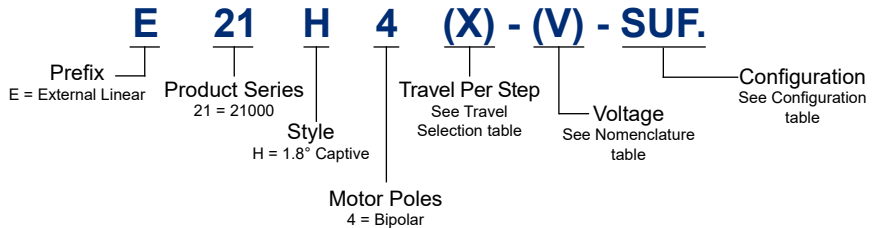
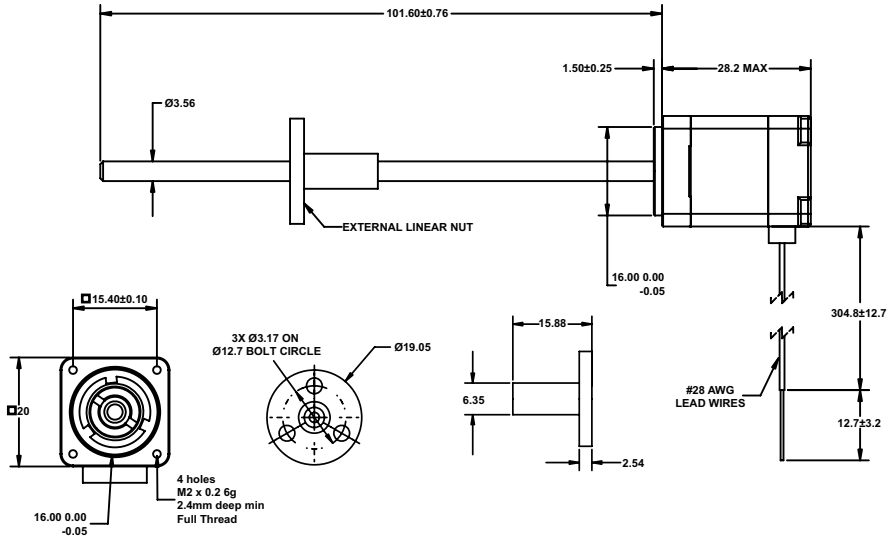

Actuators



Technical Support

- Selection Guide : Page 1-01
- Product Overview : Page 1-26
- Performance curves : Page 1-36



Nomenclature

Size 8: 21 mm Hybrid Linear Actuator (1.8° Step Angle)			
Part No.	External Linear (EH)	E21H4(X)-(V)-SUF.	
Wiring		Bipolar (4)	
Winding Voltage (V)	2.5 VDC	5 VDC	7.5 VDC
Current (RMS)/phase	0.49 A	0.24 A	0.16 A
Resistance/phase	5.1 Ω	20.4 Ω	45.9 Ω
Inductance/phase	1.5 mH	5.0 mH	11.7 mH

Motor Specification

Size 8: 21 mm Hybrid Linear Actuator (1.8° Step Angle)	
Power consumption	2.45 W Total
Rotor Inertia	1.4 gcm ²
Insulation Class	Class B (Class F available)
Weight	43g
Insulation Resistance	20MΩ

Standard motors are Class B rated for maximum temperature of 130°C.

Rating modifiers may be necessary when using the shaft fully extended or fully retracted for the whole life cycle.

*Values truncated

Travel Selection

Linear Travel/ Step	0.0015*	0.0025	0.0030*	0.005	0.006*	0.01	0.0121*	0.02	0.04
Screw Ø3.56 mm									
Part No (X)	U	AA	N	AB	K	AC	J	AD	AE

Configuration

Further resolutions available on request.

Custom leadscrew lengths are available on request.



Force vs. Pulse rate Bipolar. Chopper. 100% Duty Cycle
Ø 3.56 mm Lead-screw

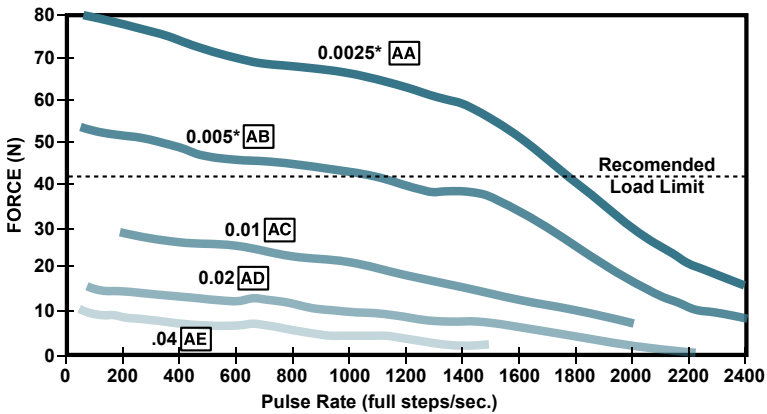
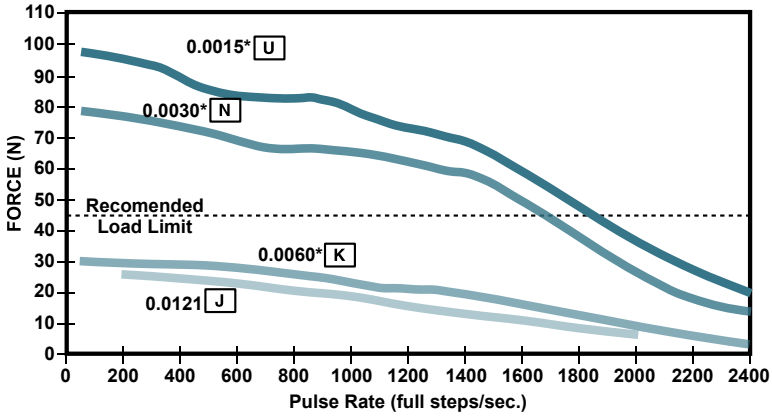

Size 8 Linear Actuator Performance Curves

21000 Series



Force vs. Linear velocity

Bipolar. Chopper. 100% Duty Cycle

Ø 3.56 mm Lead-screw

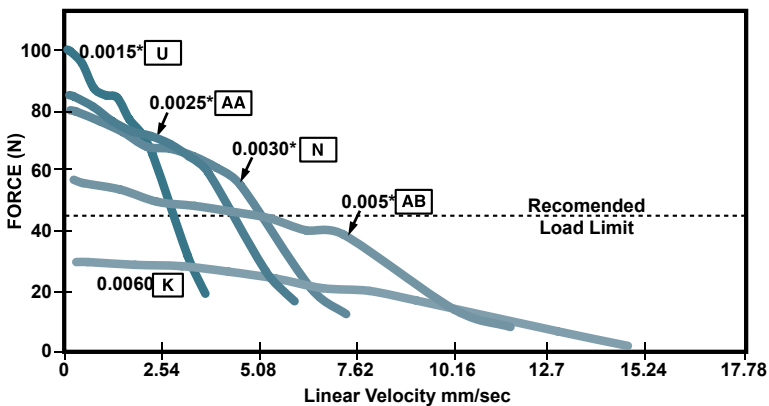
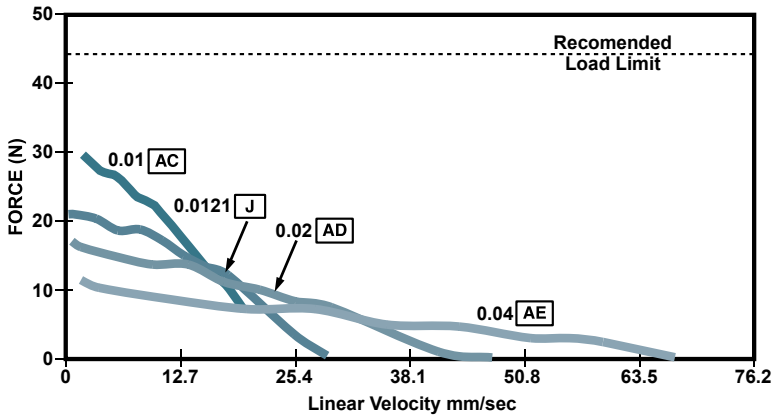

*Care should be taken that the physical load limits of the motor are not exceeded.

Please call for advice when selecting the most appropriate pitch for your application.

NOTE: All Chopper drive curves were generated using a 5 volt motor with a 40 watt power supply. Ramping can increase the performance of a motor either by increasing the top speed or accelerating a heavier load faster. Progressive deceleration can be used to stop the motor without overshoot.

With L/R drives peak force and speeds are reduced, using a unipolar drive will yield a further 30% force reduction.

Actuators



All dimensions in mm

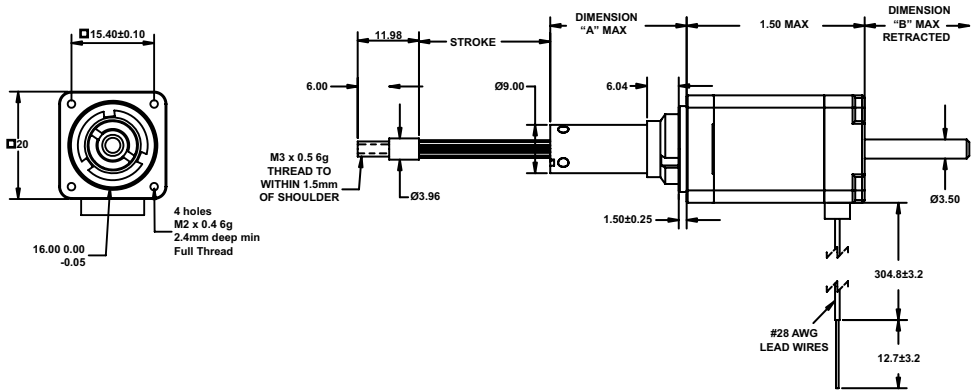

Actuators

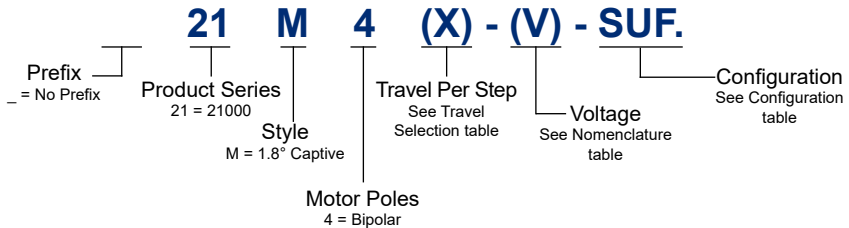

Technical Support

- Selection Guide : Page 1-01
- Product Overview : Page 1-26
- Performance curves : Page 1-44



Nomenclature

Size 8 Double Stack: 21 mm Hybrid Linear Actuator (1.8° Step Angle)			
Part No.	Captive (M)	21M4(X)-(V)-SUF.	
Wiring		Bipolar (4)	
Winding Voltage (V)	2.5 VDC	5 VDC	7.5 VDC
Current (RMS) each phase	1.32 A	0.65 A	0.43 A
Resistance each phase	1.9 Ω	7.7 Ω	17.3 Ω
Inductance each phase	1.91 mH	7.02 mH	15.95 mH

Motor Specification

Size 8 Double Stack: 21 mm Hybrid Linear Actuator (1.8° Step Angle)	
Power consumption	6.5 W Total
Rotor Inertia	2.6 gcm ²
Insulation Class	Class B (Class F available)
Weight	68g
Insulation Resistance	20MΩ

Standard motors are Class B rated for maximum temperature of 130°C.

Rating modifiers may be necessary when using the shaft fully extended or fully retracted for the whole life cycle.

*Values truncated

Travel Selection

Linear Travel/ Step	0.0025	0.0030*	0.005	0.006*	0.01	0.0121*	0.02	0.04
Screw Ø3.56 mm								
Part No (X)	AA	N	AB	K	AC	J	AD	AE

Configuration

Stroke	Dim. "A"	Dim. "B"	SUF.
9.0	11.10	1.58	-904
12.7	14.81	5.28	-905
19.05	21.16	11.63	-907
25.4	27.51	17.98	-910
31.8	33.86	24.33	-912
38.1	40.21	30.68	-915



All dimensions in mm

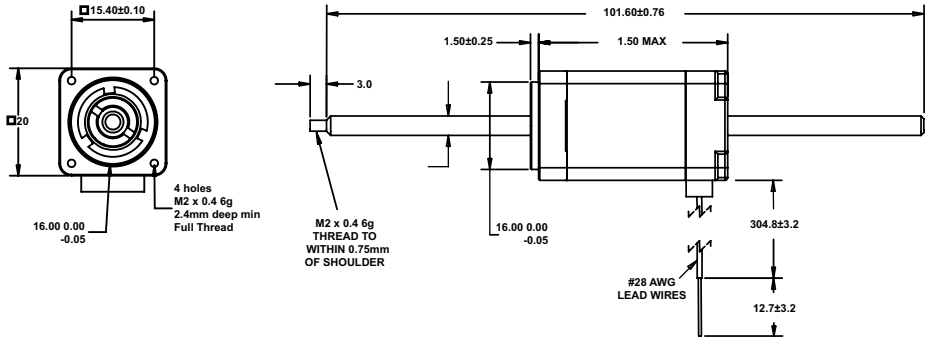

Actuators

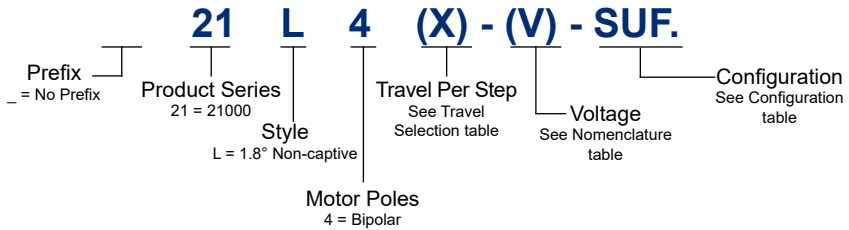

Technical Support

- Selection Guide : Page 1-01
- Product Overview : Page 1-26
- Performance curves : Page 1-44



Nomenclature

Size 8 Double Stack: 21 mm Hybrid Linear Actuator (1.8° Step Angle)				
Part No.	Non-captive (L)	21L4(X)-(V)-SUF.		
Wiring		Bipolar (4)		
Winding Voltage (V)	2.5 VDC	5 VDC	7.5 VDC	
Current (RMS)/phase	1.32 A	0.65 A	0.43 A	
Resistance/phase	1.9 Ω	7.7 Ω	17.3 Ω	
Inductance/phase	1.91 mH	7.02 mH	15.95 mH	

Motor Specification

Size 8 Double Stack: 21 mm Hybrid Linear Actuator (1.8° Step Angle)	
Power consumption	6.5 W Total
Rotor Inertia	2.6 gcm ²
Insulation Class	Class B (Class F available)
Weight	68g
Insulation Resistance	20MΩ

Standard motors are Class B rated for maximum temperature of 130°C.

Rating modifiers may be necessary when using the shaft fully extended or fully retracted for the whole life cycle.

*Values truncated

Travel Selection

Linear Travel/ Step	0.0015*	0.0025	0.0030*	0.005	0.006*	0.01	0.0121*	0.02	0.04
Screw Ø3.56 mm									
Part No (X)	U	AA	N	AB	K	AC	J	AD	AE

Configuration

Further resolutions available on request.

Custom leadscrew lengths are available on request.



All dimensions in mm

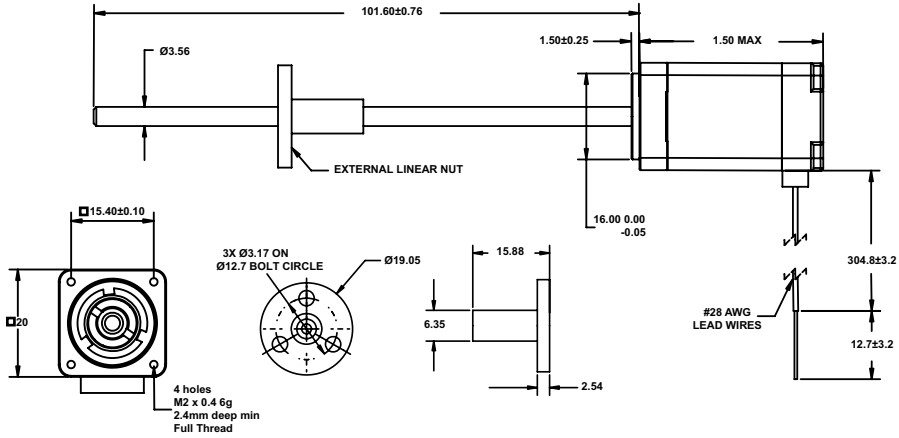

Actuators

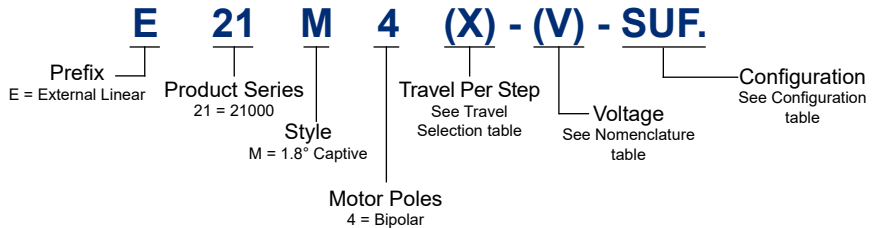

Technical Support

- Selection Guide : Page 1-01
- Product Overview : Page 1-26
- Performance curves : Page 1-44



Nomenclature

Size 8 Double Stack: 21 mm Hybrid Linear Actuator (1.8° Step Angle)			
Part No.	External Linear (EM)	E21M4(X)-(V)-SUF.	
Wiring		Bipolar (4)	
Winding Voltage (V)	2.5 VDC	5 VDC	7.5 VDC
Current (RMS)/phase	1.32 A	0.65 A	0.43 A
Resistance/phase	1.9 Ω	7.7 Ω	17.3 Ω
Inductance/phase	1.91 mH	7.02 mH	15.95 mH

Motor Specification

Size 8 Double Stack: 21 mm Hybrid Linear Actuator (1.8° Step Angle)	
Power consumption	6.5 W Total
Rotor Inertia	2.6 gcm ²
Insulation Class	Class B (Class F available)
Weight	68g
Insulation Resistance	20MΩ

Standard motors are Class B rated for maximum temperature of 130°C.

Rating modifiers may be necessary when using the shaft fully extended or fully retracted for the whole life cycle.

*Values truncated

Travel Selection

Linear Travel/ Step	0.0015*	0.0025	0.0030*	0.005	0.006*	0.01	0.0121*	0.02	0.04
Screw Ø3.56 mm									
Part No (X)	U	AA	N	AB	K	AC	J	AD	AE

Configuration

Further resolutions available on request.

Custom leadscrew lengths are available on request.



Force vs. Pulse Rate Bipolar. Chopper. 100% Duty Cycle
Ø 3.56 mm Lead-screw

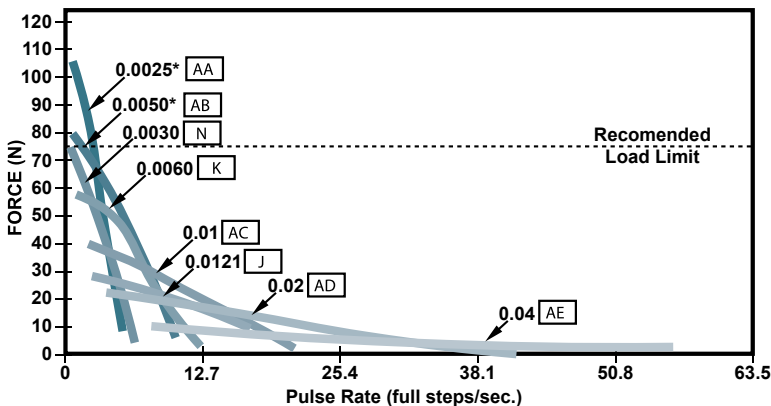
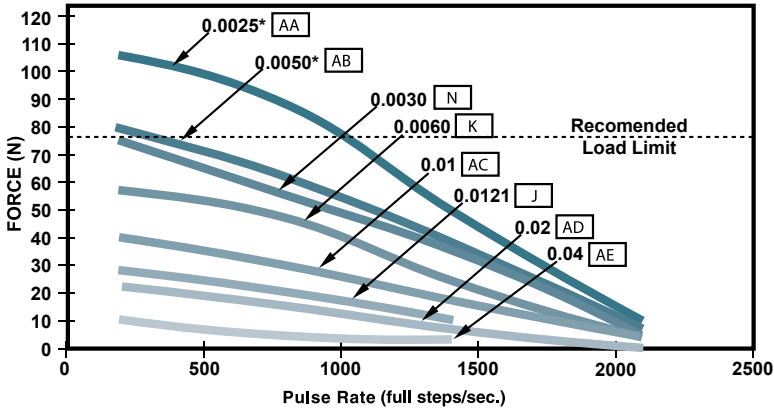

*Care should be taken that the physical load limits of the motor are not exceeded.

Please call for advice when selecting the most appropriate pitch for your application.

NOTE: All Chopper drive curves were generated using a 5 volt motor with a 40 watt power supply. Ramping can increase the performance of a motor either by increasing the top speed or accelerating a heavier load faster. Progressive deceleration can be used to stop the motor without overshoot.

With L/R drives peak force and speeds are reduced, using a unipolar drive will yield a further 30% force reduction.

Actuators

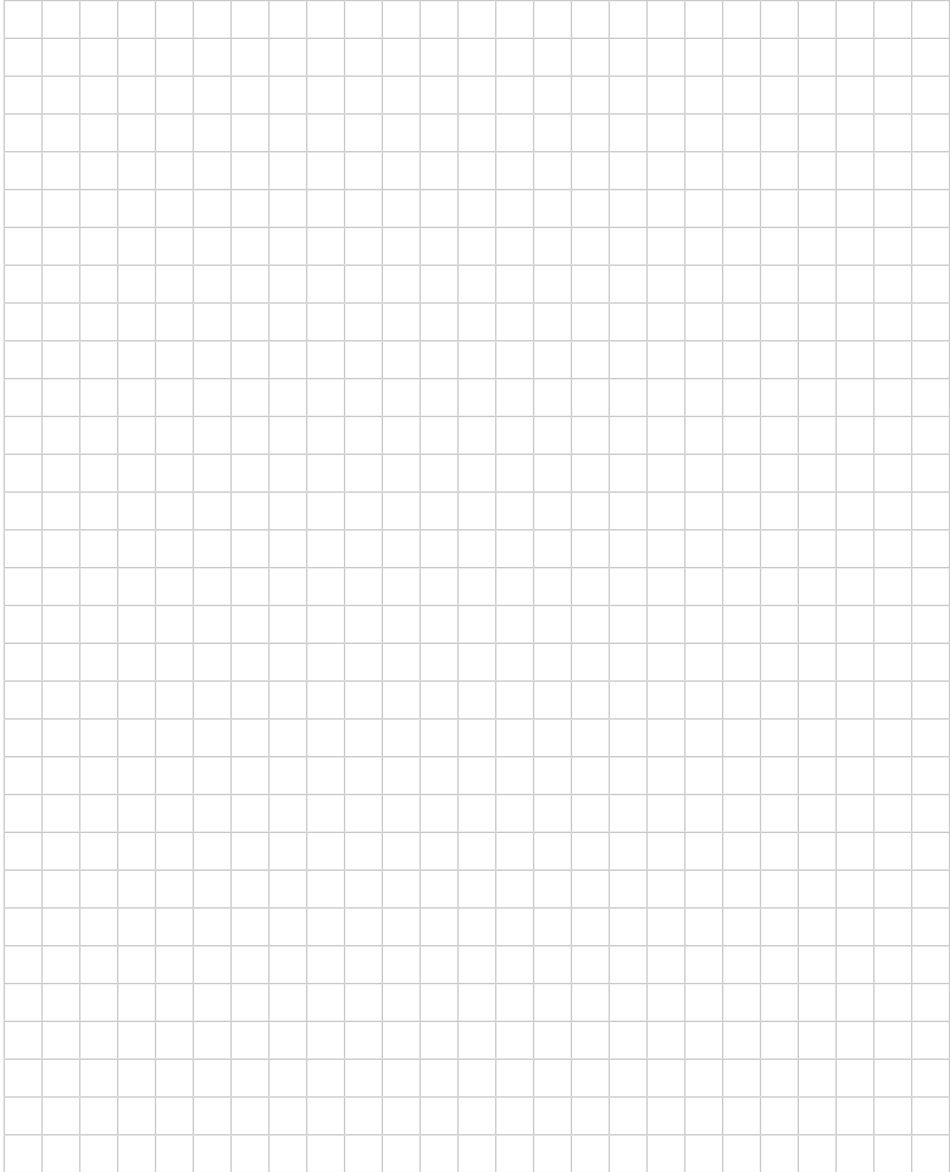



All dimensions in mm

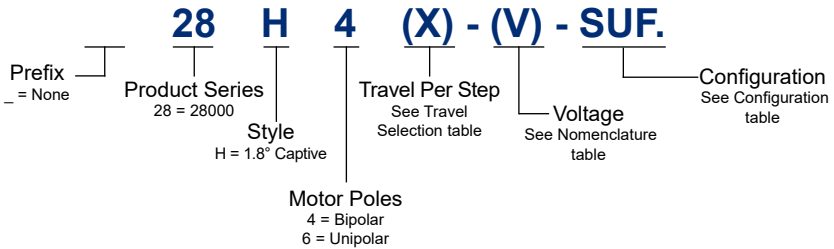
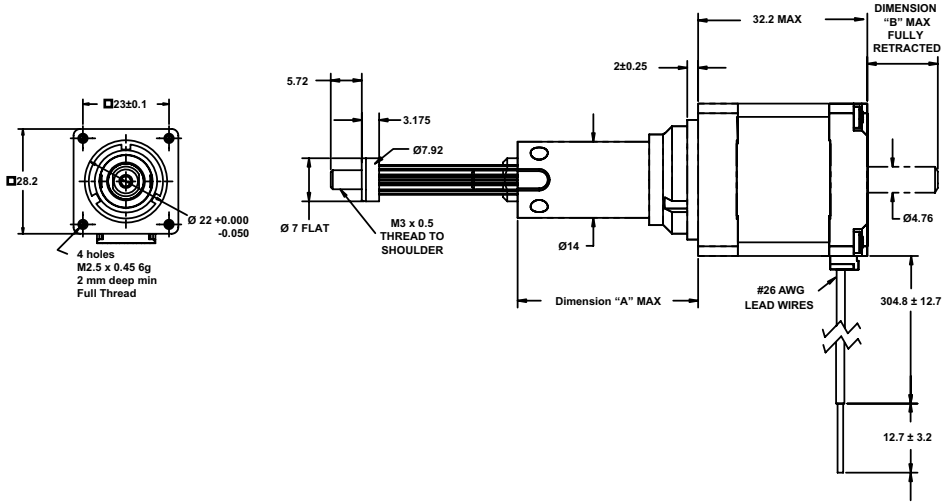

Actuators



Technical Support

- Selection Guide : Page 1-01
- Product Overview : Page 1-26
- Performance curves : Page 1-52



Nomenclature

Size 11: 28 mm Hybrid Linear Actuator (1.8° Step Angle)						
Part No.	Captive (H)	28H4(X)-(V)-SUF.			28H6-(X)-(V)-SUF.	
Wiring		Bipolar (4)			Unipolar** (6)	
Winding Voltage (V)		2.1 VDC	5 VDC	12 VDC	5 VDC	12 VDC
Current (RMS) each phase		1.0 A	0.42 A	0.18 A	0.42 A	0.18 A
Resistance each phase		2.1Ω	11.9Ω	68.6Ω	11.9Ω	68.6Ω
Inductance each phase		1.5mH	6.7mH	39.0mH	3.3mH	19.5mH

Motor Specification

Size 11: 28 mm Hybrid Linear Actuator (1.8° Step Angle)	
Power consumption	4.2 W Total
Rotor Inertia	9.0 gcm ²
Insulation Class	Class B (Class F available)
Weight	119g
Insulation Resistance	20MΩ

Standard motors are Class B rated for maximum temperature of 130°C.

Rating modifiers may be necessary when using the shaft fully extended or fully retracted for the whole life cycle.

**Unipolar drive gives approx 30% less thrust than Bipolar.

*Values truncated

Travel Selection

Linear Travel/ Step	0.0031*	0.0063*	0.0127	0.0254	0.508
Screw Ø4.75 mm					
Part No (X)	7	9	3	1	2

Configuration

Stroke	Dim. "A"	Dim. "B"	SUF.
12.7	20.47	1.68	-905
19.05	26.82	8.03	-907
25.4	33.17	14.38	-910
31.75	39.52	20.73	-912
38.1	45.87	27.08	-915
50.8	58.57	39.78	-920
63.5	71.27	52.48	-925

Further resolutions available on request.

Custom leadscrew lengths are available on request.



All dimensions in mm

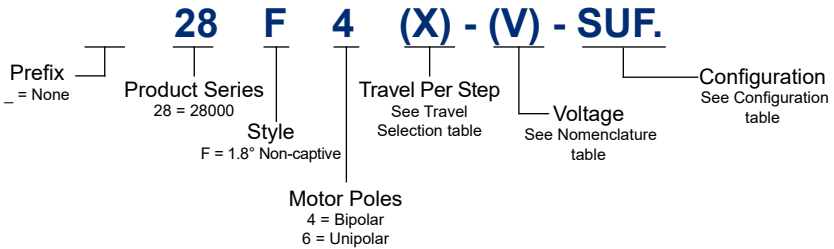
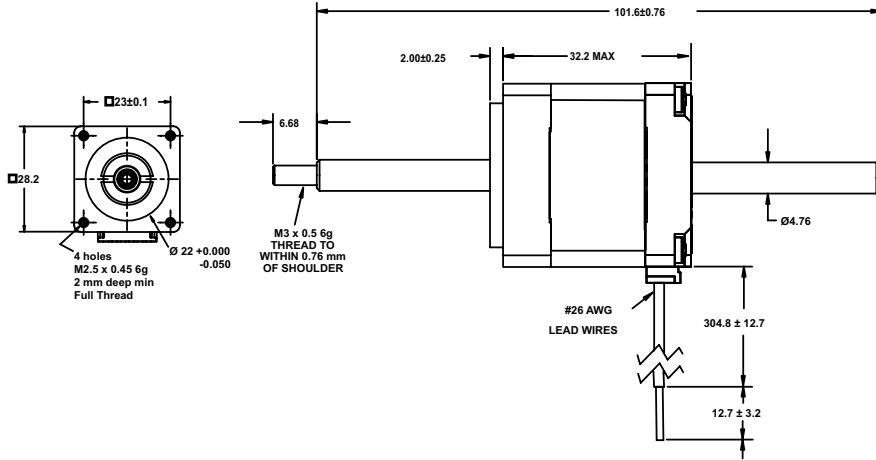

Technical Support

- Selection Guide : Page 1-01
- Product Overview : Page 1-26
- Performance curves : Page 1-52

Actuators



Nomenclature

Size 11: 28 mm Hybrid Linear Actuator (1.8° Step Angle)						
Part No.	Captive (F)	28F4(X)-(V)-SUF.			28F6-(X)-(V)-SUF.	
Wiring		BIPOLAR (4)			Unipolar** (6)	
Winding Voltage (V)		2.1 VDC	5 VDC	12 VDC	5 VDC	12 VDC
Current (RMS) each phase		1.0 A	0.42 A	0.18 A	0.42 A	0.18 A
Resistance each phase		2.1Ω	11.9Ω	68.6Ω	11.9Ω	68.6Ω
Inductance each phase		1.5mH	6.7mH	39.0mH	3.3mH	19.5mH

Motor Specification

Size 11: 28 mm Hybrid Linear Actuator (1.8° Step Angle)	
Power consumption	4.2 W Total
Rotor Inertia	9.0 gcm ²
Insulation Class	Class B (Class F available)
Weight	119g
Insulation Resistance	20MΩ

Standard motors are Class B rated for maximum temperature of 130°C.

Rating modifiers may be necessary when using the shaft fully extended or fully retracted for the whole life cycle.

**Unipolar drive gives approx 30% less thrust than Bipolar.

*Values truncated

Travel Selection

Linear Travel/ Step	0.0031*	0.0063*	0.0127	0.0254	0.508
Screw Ø4.75 mm					
Part No (X)	7	9	3	1	2

Configuration

Further resolutions available on request.

Custom leadscrew lengths are available on request.



All dimensions in mm

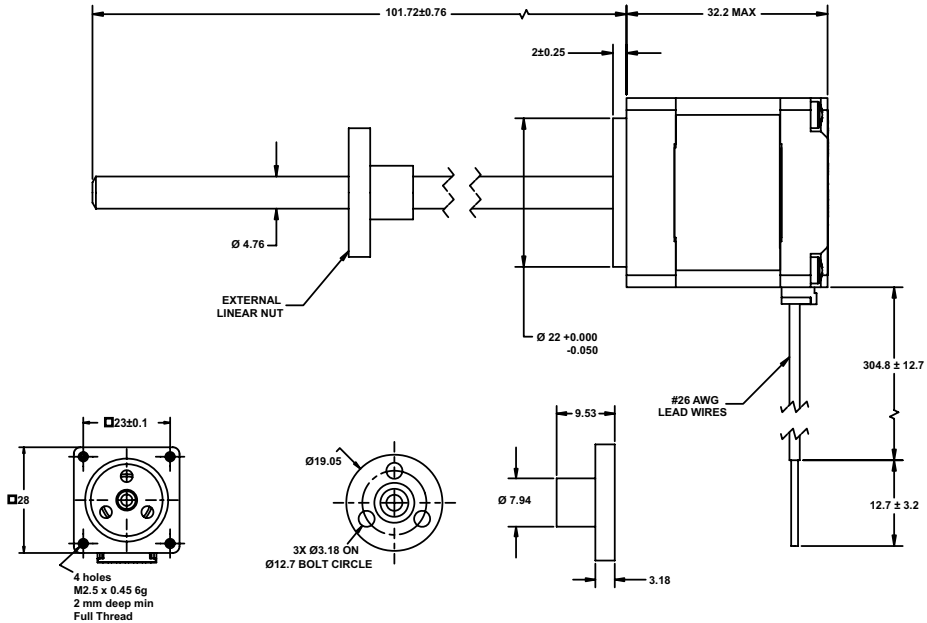

E 28 H 4 (X) - (V) - SUF.

Prefix: E = External Linear

Product Series: 28 = 28000

Style: H = 1.8° Captive

Motor Poles: 4 = Bipolar, 6 = Unipolar

Travel Per Step: See Travel Selection table

Voltage: See Nomenclature table

Configuration: See Configuration table

Actuators



Technical Support

- Selection Guide : Page 1-01
- Product Overview : Page 1-26
- Performance curves : Page 1-52



Nomenclature

Size 11: 28 mm Hybrid Linear Actuator (1.8° Step Angle)						
Part No.	Captive (H)	28H4(X)-(V)-SUF.			28H6-(X)-(V)-SUF.	
Wiring		BIPOLAR (4)			Unipolar** (6)	
Winding Voltage (V)		2.1 VDC	5 VDC	12 VDC	5 VDC	12 VDC
Current (RMS) each phase		1.0 A	0.42 A	0.18 A	0.42 A	0.18 A
Resistance each phase		2.1Ω	11.9Ω	68.6Ω	11.9Ω	68.6Ω
Inductance each phase		1.5mH	6.7mH	39.0mH	3.3mH	19.5mH

Motor Specification

Size 11: 28 mm Hybrid Linear Actuator (1.8° Step Angle)	
Power consumption	4.2 W Total
Rotor Inertia	9.0 gcm ²
Insulation Class	Class B (Class F available)
Weight	119g
Insulation Resistance	20MΩ

Standard motors are Class B rated for maximum temperature of 130°C.

Rating modifiers may be necessary when using the shaft fully extended or fully retracted for the whole life cycle.

**Unipolar drive gives approx 30% less thrust than Bipolar.

*Values truncated

Travel Selection

Linear Travel/ Step	0.0031*	0.0063*	0.0127	0.0254	0.508
Screw Ø4.75 mm					
Part No (X)	7	9	3	1	2

Configuration

Further resolutions available on request.

Custom leadscrew lengths are available on request.



Force vs. Pulse Rate Bipolar. Chopper. 100% Duty Cycle Ø 4.75 mm Lead-screw

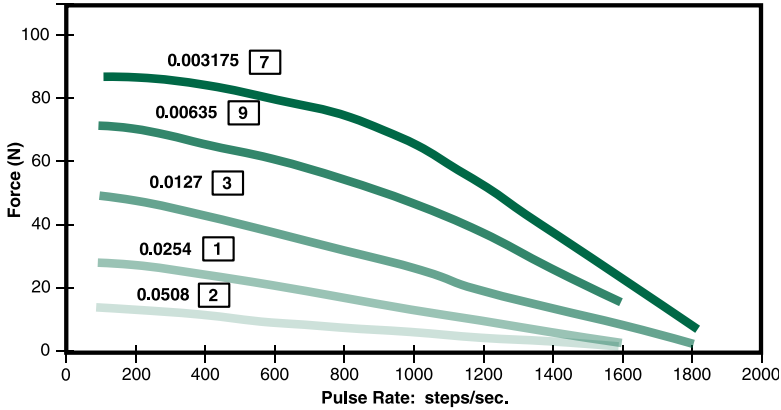

Force vs. Linear Velocity Bipolar. Chopper. 100% Duty Cycle Ø 4.75 mm Lead-screw

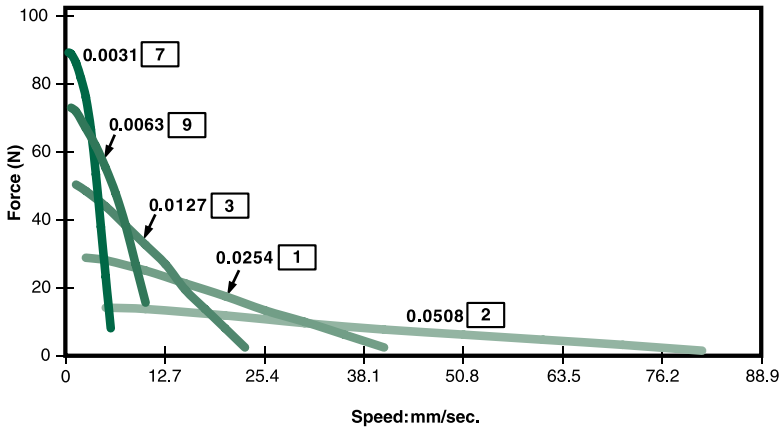

*Care should be taken that the physical load limits of the motor are not exceeded.

Please call for advice when selecting the most appropriate pitch for your application.

NOTE: All Chopper drive curves were generated using a 5 volt motor with a 40 watt power supply. Ramping can increase the performance of a motor either by increasing the top speed or accelerating a heavier load faster. Progressive deceleration can be used to stop the motor without overshoot.

With L/R drives peak force and speeds are reduced, using a unipolar drive will yield a further 30% force reduction.

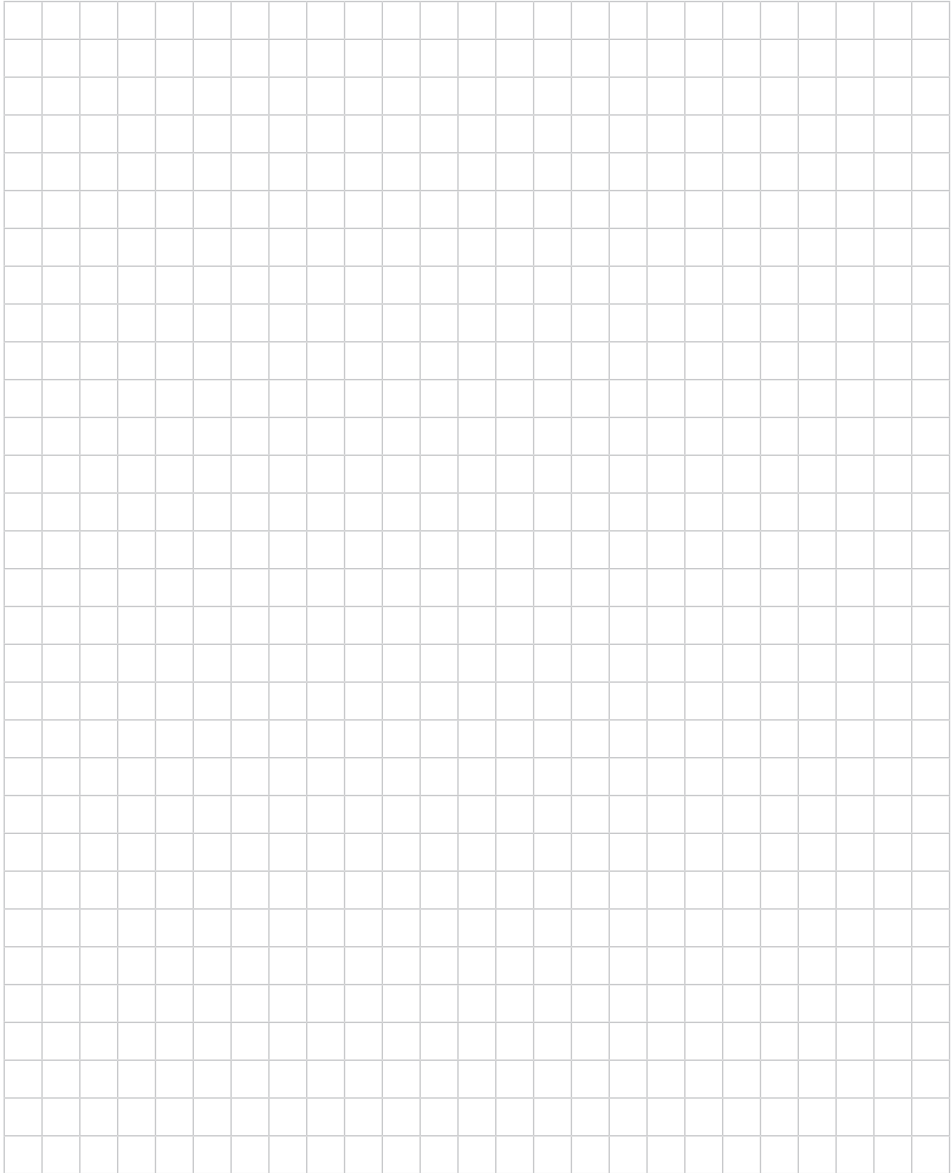



All dimensions in mm

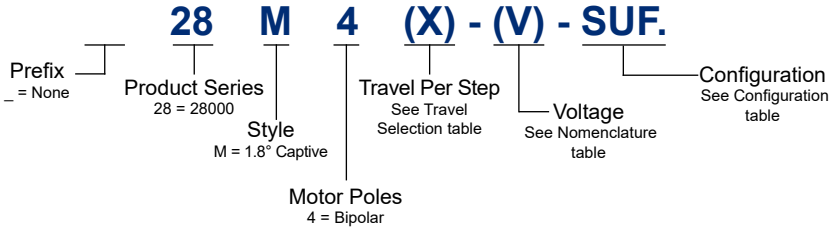
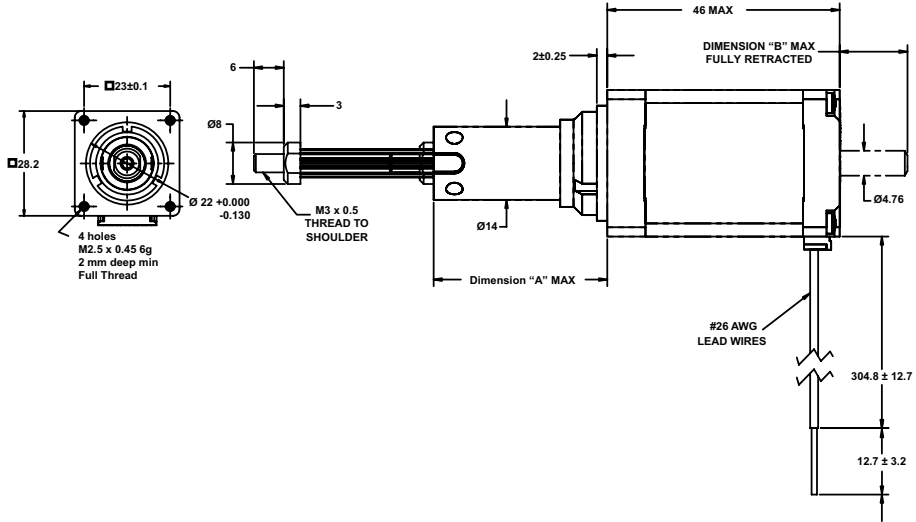

Technical Support

- Selection Guide : Page 1-01
- Product Overview : Page 1-26
- Performance curves : Page 1-60



Nomenclature

Size 11 Double Stack : 28 mm Hybrid Linear Actuator (1.8° Step Angle)			
Part No.	Captive (M)	28M4(X)-(V)	
Wiring		BIPOLAR (4)	
Winding Voltage (V)	2.1 VDC	5 VDC	12 VDC
Current (RMS) each phase	1.9 A	750 mA	350 mA
Resistance each phase	1.1Ω	6.7Ω	34.8Ω
Inductance each phase	1.1mH	5.8mH	35.6mH

Motor Specification

Size 11 Double Stack : 28 mm Hybrid Linear Actuator (1.8° Step Angle)	
Power consumption	7.5 W Total
Rotor Inertia	13.5 gcm ²
Insulation Class	Class B (Class F available)
Weight	180g
Insulation Resistance	20MΩ

Standard motors are Class B rated for maximum temperature of 130°C.

Rating modifiers may be necessary when using the shaft fully extended or fully retracted for the whole life cycle.

*Values truncated

Travel Selection

Linear Travel/ Step	0.0031*	0.0063*	0.0127	0.0254	0.508
Screw Ø4.75 mm					
Part No (X)	7	9	3	1	2

Configuration

Stroke	Dim. "A"	Dim. "B"	SUF.
12.7	20.5	2.3	-905
19.05	26.8	8.6	-907
25.4	33.17	15.0	-910
31.75	39.5	21.35	-912
38.1	72.7	27.7	-915
50.8	85.4	40.4	-920
63.5	98.1	53.1	-925

Further resolutions available on request.

Custom leadscrew lengths are available on request.



All dimensions in mm

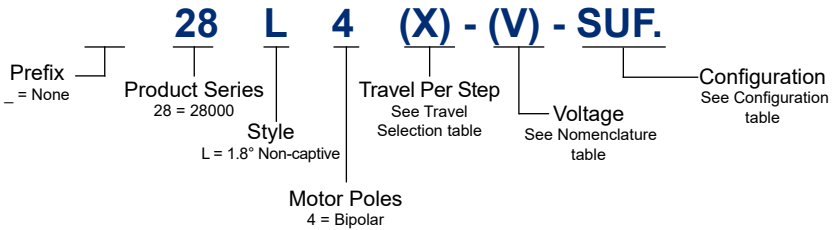
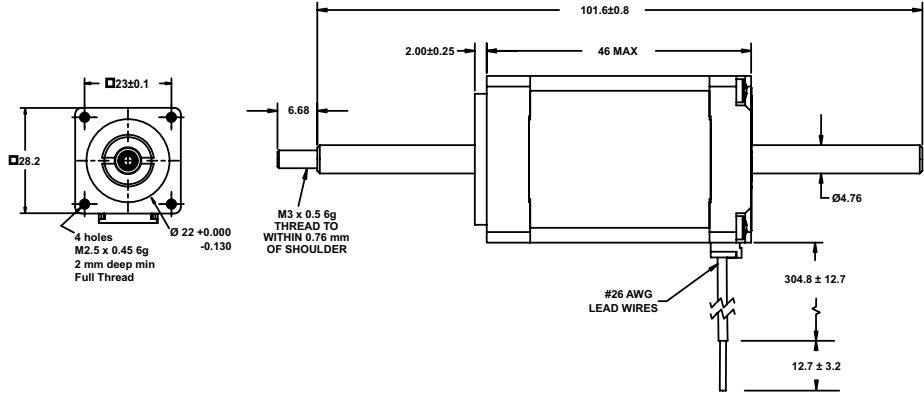

Actuators

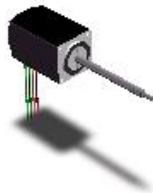

Technical Support

- Selection Guide : Page 1-01
- Product Overview : Page 1-26
- Performance curves : Page 1-60



Nomenclature

Size 11 Double Stack : 28 mm Hybrid Linear Actuator (1.8° Step Angle)				
Part No.	Non-captive (L)	28L4(X)-(V)		
Wiring		BIPOLAR (4)		
Winding Voltage (V)		2.1 VDC	5 VDC	12 VDC
Current (RMS) each phase		1.9 A	750 mA	350 mA
Resistance each phase		1.1Ω	6.7Ω	34.8Ω
Inductance each phase		1.1mH	5.8mH	35.6mH

Motor Specification

Size 11 Double Stack : 28 mm Hybrid Linear Actuator (1.8° Step Angle)	
Power consumption	7.5 W Total
Rotor Inertia	13.5 gcm ²
Insulation Class	Class B (Class F available)
Weight	180g
Insulation Resistance	20MΩ

Standard motors are Class B rated for maximum temperature of 130°C.

Rating modifiers may be necessary when using the shaft fully extended or fully retracted for the whole life cycle.

*Values truncated

Travel Selection

Linear Travel/ Step	0.0031*	0.0063*	0.0127	0.0254	0.508
Screw Ø4.75 mm					
Part No (X)	7	9	3	1	2

Configuration

Further resolutions available on request.

Custom leadscrew lengths are available on request.



All dimensions in mm

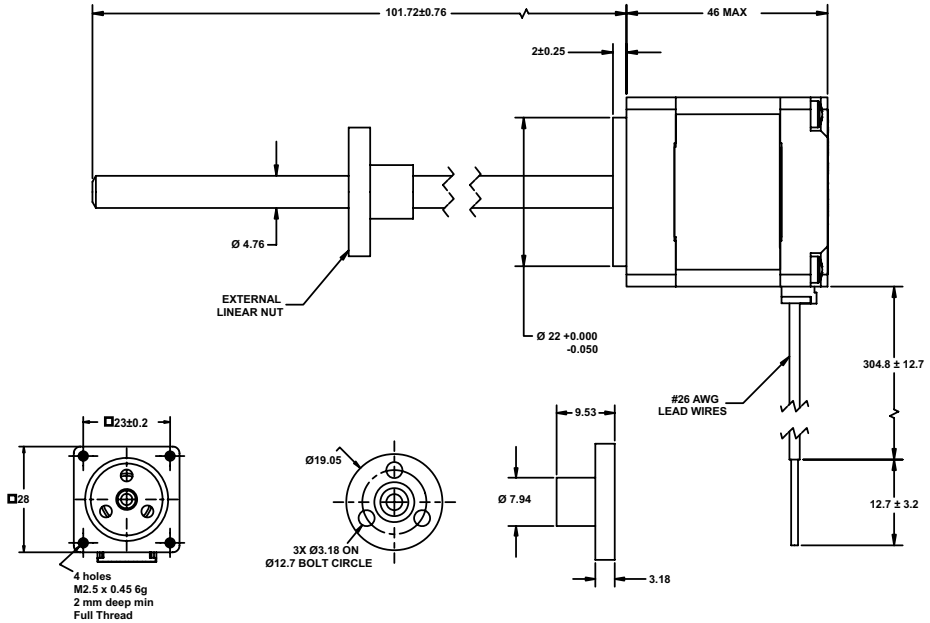

E 28 M 4 (X) - (V) - SUF.

Prefix: E = External Linear

Product Series: 28 = 28000

Style: M = H = 1.8° Captive

Motor Poles: 4 = Bipolar

Travel Per Step: (X) - See Travel Selection table

Voltage: (V) - See Nomenclature table

Configuration: SUF - See Configuration table

Actuators

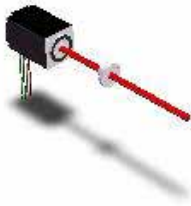

Technical Support

- Selection Guide : Page 1-01
- Product Overview : Page 1-26
- Performance curves : Page 1-60



Nomenclature

Size 11 Double Stack : 28 mm Hybrid Linear Actuator (1.8° Step Angle)			
Part No.	External Linear (EM)	E28M4(X)-(V)	
Wiring		BIPOLAR (4)	
Winding Voltage (V)	2.1 VDC	5 VDC	12 VDC
Current (RMS) each phase	1.9 A	750 mA	350 mA
Resistance each phase	1.1Ω	6.7Ω	34.8Ω
Inductance each phase	1.1mH	5.8mH	35.6mH

Motor Specification

Size 11 Double Stack : 28 mm Hybrid Linear Actuator (1.8° Step Angle)	
Power consumption	7.5 W Total
Rotor Inertia	13.5 gcm ²
Insulation Class	Class B (Class F available)
Weight	180g
Insulation Resistance	20MΩ

Standard motors are Class B rated for maximum temperature of 130°C.

Rating modifiers may be necessary when using the shaft fully extended or fully retracted for the whole life cycle.

*Values truncated

Travel Selection

Linear Travel/ Step	0.0031*	0.0063*	0.0127	0.0254	0.508
Screw Ø4.75 mm					
Part No (X)	7	9	3	1	2

Configuration

Further resolutions available on request.

Custom leadscrew lengths are available on request.



Force vs. Pulse Rate Bipolar. Chopper. 100% Duty Cycle
Ø 4.75 mm Lead-screw

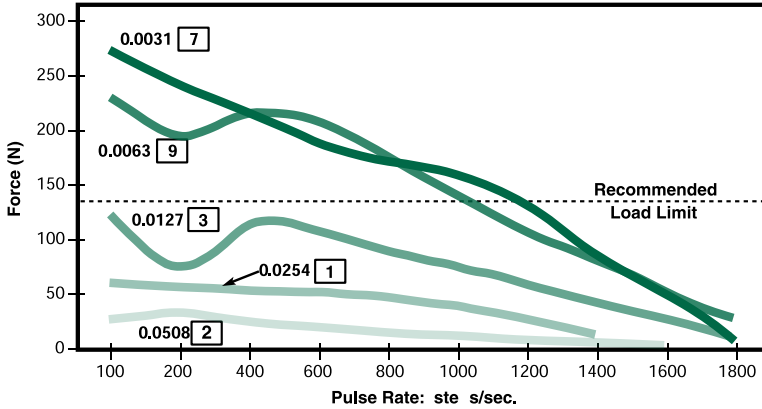

Force vs. Linear Velocity Bipolar. Chopper. 100% Duty Cycle
Ø 4.75 mm Lead-screw

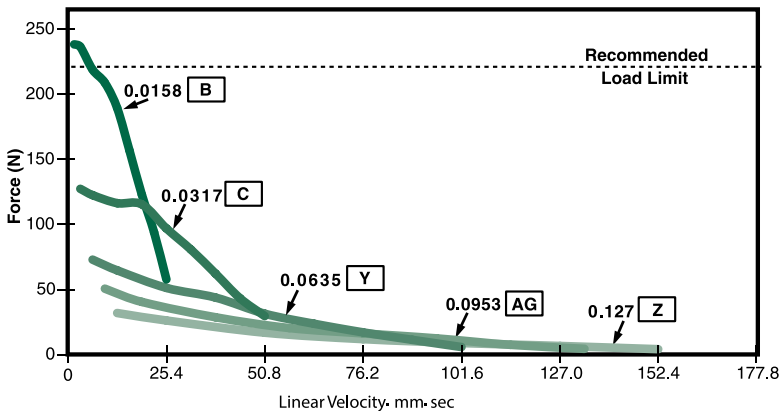

*Care should be taken that the physical load limits of the motor are not exceeded.

Please call for advice when selecting the most appropriate pitch for your application.

NOTE: All Chopper drive curves were generated using a 5 volt motor with a 40 watt power supply. Ramping can increase the performance of a motor either by increasing the top speed or accelerating a heavier load faster. Progressive deceleration can be used to stop the motor without overshoot.

With L/R drives peak force and speeds are reduced, using a unipolar drive will yield a further 30% force reduction.

Actuators



All dimensions in mm

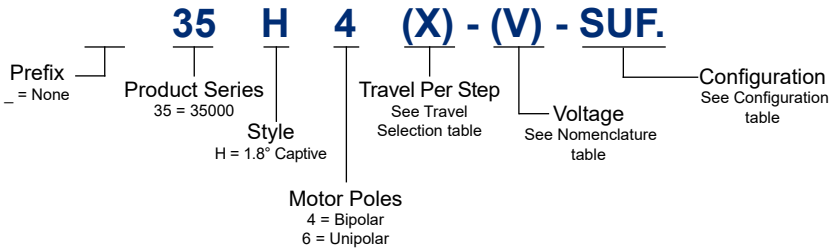
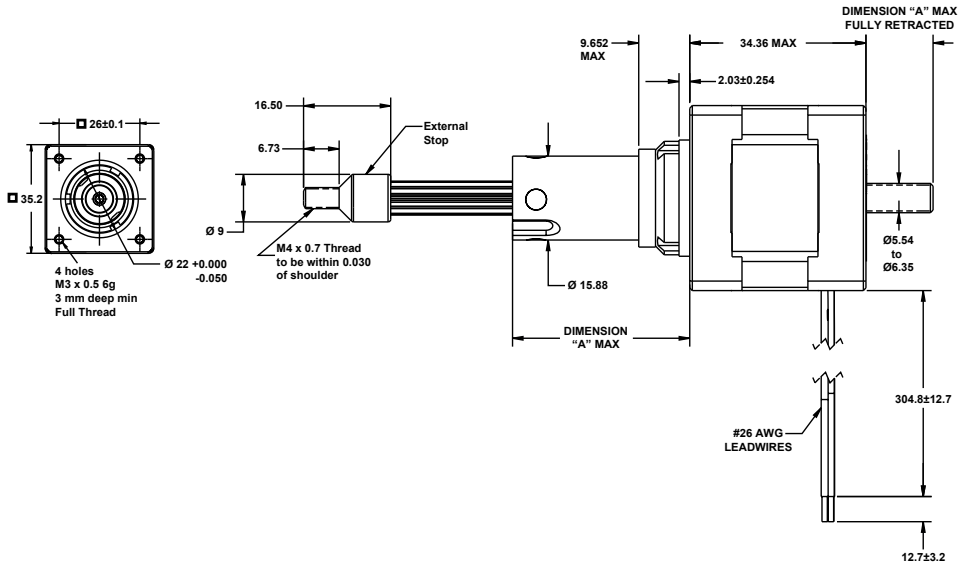

Technical Support

- Selection Guide : Page 1-01
- Product Overview : Page 1-26
- Performance curves : Page 1-68



Nomenclature

Size 14: 35 mm Hybrid Linear Actuator (1.8° Step Angle)						
Part No.	Captive (H)	35H4(X)-(V)-SUF.			35H6-(X)-(V)-SUF.	
Wiring		BIPOLAR (4)			Unipolar** (6)	
Winding Voltage (V)		2.33 VDC	5 VDC	12 VDC	5 VDC	12 VDC
Current (RMS) each phase		125 A	0.57 A	0.24 A	0.57 A	0.24 A
Resistance each phase		1.86Ω	8.8Ω	50.5Ω	8.8Ω	50.5Ω
Inductance each phase		2.8mH	13mH	60mH	6.5mH	30mH

Motor Specification

Size 14: 35 mm Hybrid Linear Actuator (1.8° Step Angle)	
Power consumption	5.7 W Total
Rotor Inertia	16.0 gcm ²
Insulation Class	Class B (Class F available)
Weight	162g
Insulation Resistance	20MΩ

Standard motors are Class B rated for maximum temperature of 130°C.

Rating modifiers may be necessary when using the shaft fully extended or fully retracted for the whole life cycle.

**Unipolar drive gives approx 30% less thrust than Bipolar.

*Values truncated

Travel Selection

Linear Travel/ Step	0.0030*	0.0060*	0.0121*	0.0243*	0.0487*
Screw Ø5.54 mm					
Part No (X)	N	K	J	Q	R
Linear Travel/Step	0.0039*	0.0079*	0.0158*	0.0317*	
Screw Ø6.35 mm					
Part No (X)	P	A	B	C	

Configuration

Stroke	Dim. "A"	Dim. "B"	SUF.
12.7	20.8	1.0	-905
19.05	27.2	7.4	-907
25.4	33.5	13.7	-910
31.75	39.9	20.1	-912
38.1	46.2	26.4	-915
50.8	58.9	39.1	-920
63.5	71.6	51.8	-925

Further resolutions available on request.

Custom leadscrew lengths are available on request.



35000 Series

Size 14 Linear Actuator Non-captive Shaft

All dimensions in mm

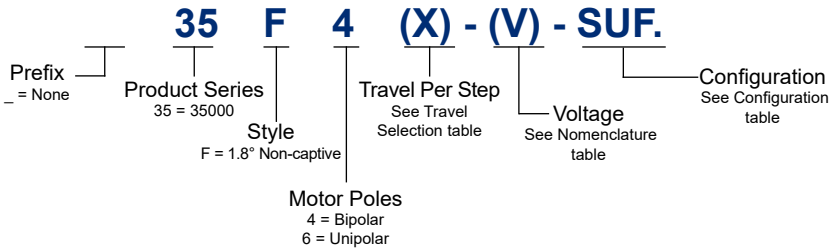
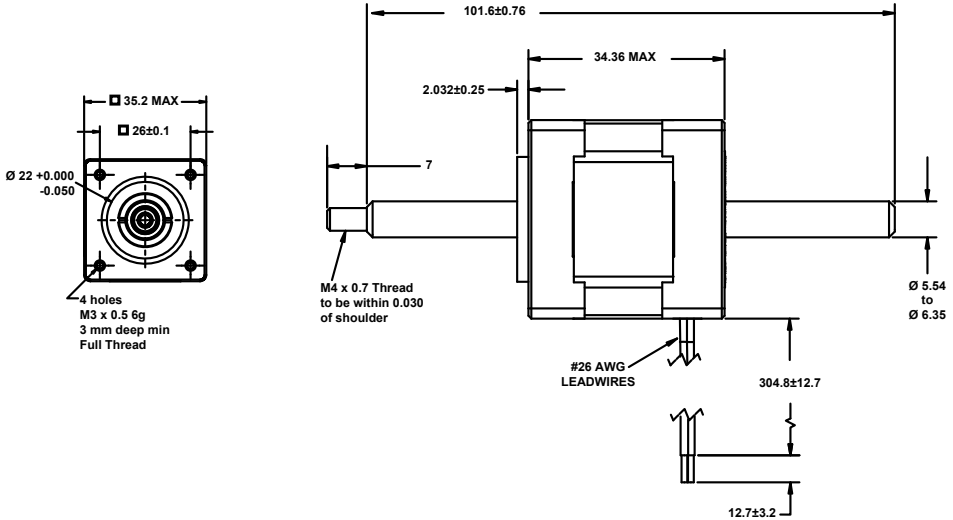

Technical Support

- Selection Guide : Page 1-01
- Product Overview : Page 1-26
- Performance curves : Page 1-68

Actuators



Nomenclature

Size 14: 35 mm Hybrid Linear Actuator (1.8° Step Angle)						
Part No.	Non-captive (F)	35F4(X)-(V)-SUF.			35F6-(X)-(V)-SUF.	
Wiring		BIPOLAR (4)			Unipolar** (6)	
Winding Voltage (V)		2.33 VDC	5 VDC	12 VDC	5 VDC	12 VDC
Current (RMS) each phase		125 A	0.57 A	0.24 A	0.57 A	0.24 A
Resistance each phase		1.86Ω	8.8Ω	50.5Ω	8.8Ω	50.5Ω
Inductance each phase		2.8mH	13mH	60mH	6.5mH	30mH

Motor Specification

Size 14: 35 mm Hybrid Linear Actuator (1.8° Step Angle)	
Power consumption	5.7 W Total
Rotor Inertia	16.0 gcm ²
Insulation Class	Class B (Class F available)
Weight	162g
Insulation Resistance	20MΩ

Standard motors are Class B rated for maximum temperature of 130°C.

Rating modifiers may be necessary when using the shaft fully extended or fully retracted for the whole life cycle.

**Unipolar drive gives approx 30% less thrust than Bipolar.

*Values truncated

Travel Selection

Linear Travel/ Step	0.0030*	0.0060*	0.0121*	0.0243*	0.0487*
Screw Ø5.54 mm					
Part No (X)	N	K	J	Q	R
Linear Travel/Step	0.0039*	0.0079*	0.0158*	0.0317*	
Screw Ø6.35 mm					
Part No (X)	P	A	B	C	

Configuration

Further resolutions available on request.

Custom leadscrew lengths are available on request.



All dimensions in mm

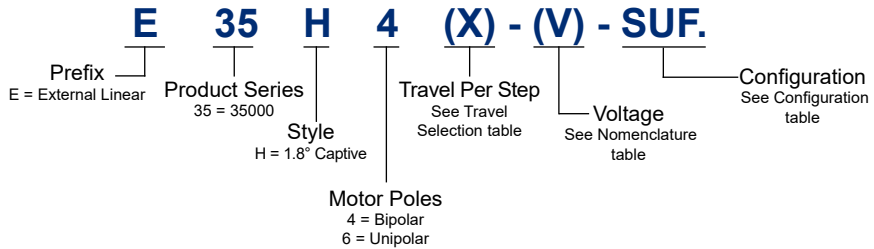
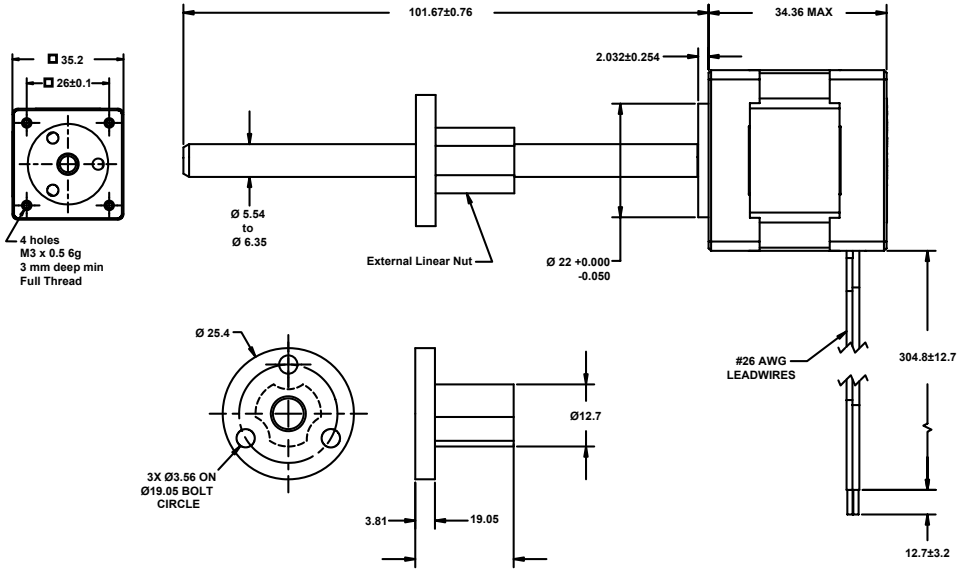

Technical Support

- Selection Guide : Page 1-01
- Product Overview : Page 1-26
- Performance curves : Page 1-68



Nomenclature

Size 14: 35 mm Hybrid Linear Actuator (1.8° Step Angle)						
Part No.	External Linear (EH)	E35H4(X)-(V)-SUF.			E35H6(X)-(V)-SUF.	
Wiring		BIPOLAR (4)			Unipolar** (6)	
Winding Voltage (V)		2.33 VDC	5 VDC	12 VDC	5 VDC	12 VDC
Current (RMS) each phase		125 A	0.57 A	0.24 A	0.57 A	0.24 A
Resistance each phase		1.86Ω	8.8Ω	50.5Ω	8.8Ω	50.5Ω
Inductance each phase		2.8mH	13mH	60mH	6.5Mh	30mH

Motor Specification

Size 14: 35 mm Hybrid Linear Actuator (1.8° Step Angle)	
Power consumption	5.7 W Total
Rotor Inertia	16.0 gcm ²
Insulation Class	Class B (Class F available)
Weight	162g
Insulation Resistance	20MΩ

Standard motors are Class B rated for maximum temperature of 130°C.

Rating modifiers may be necessary when using the shaft fully extended or fully retracted for the whole life cycle.

**Unipolar drive gives approx 30% less thrust than Bipolar.

*Values truncated

Travel Selection

Linear Travel/ Step	0.0030*	0.0060*	0.0121*	0.0243*	0.0487*
Screw Ø5.54 mm					
Part No (X)	N	K	J	Q	R
Linear Travel/Step	0.0039*	0.0079*	0.0158*	0.0317*	
Screw Ø6.35 mm					
Part No (X)	P	A	B	C	

Configuration

Further resolutions available on request.

Custom leadscrew lengths are available on request.



Force vs. Pulse rate Bipolar. Chopper. 100% Duty Cycle
Ø 5.54 mm Lead-screw

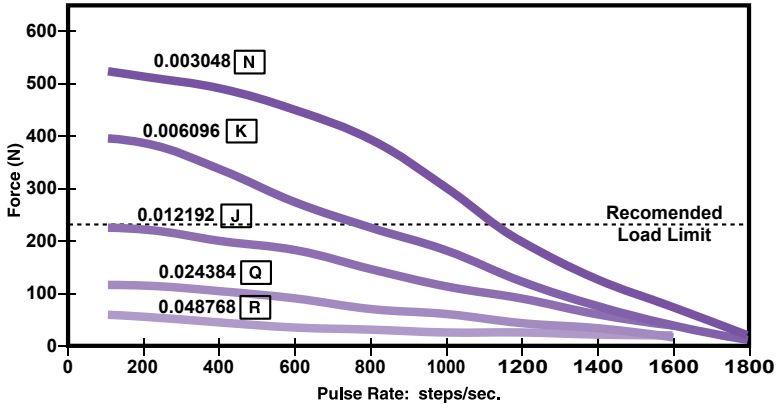

Ø 6.35 mm Lead-screw

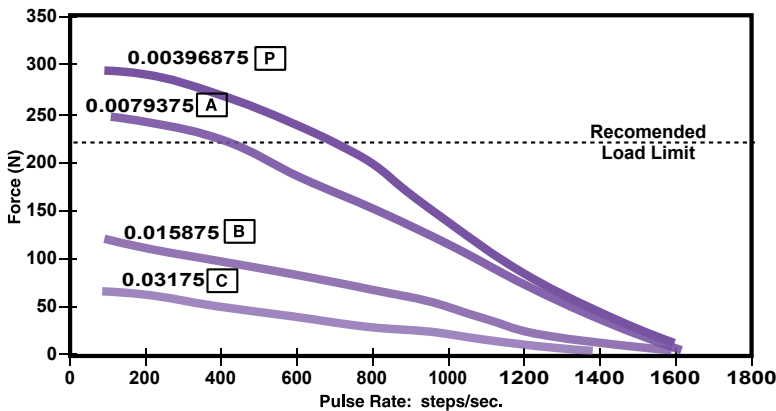

Actuators

Size 14 Linear Actuator Performance Curves

3500 Series



Force vs. Linear Velocity

Bipolar. Chopper. 100% Duty Cycle

Ø 5.54 mm Lead-screw

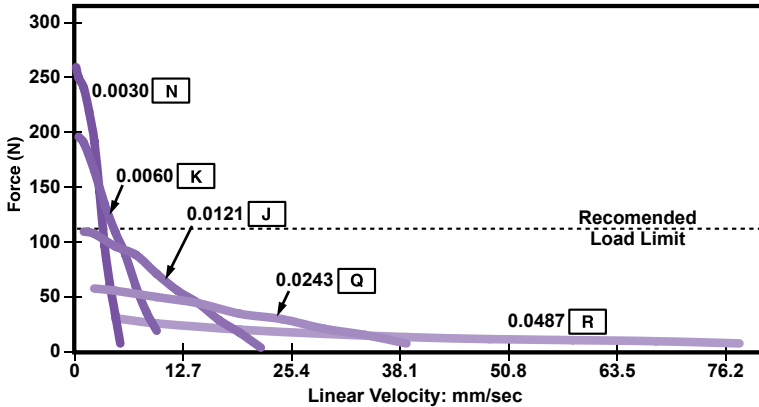

Ø 6.35 mm Lead-screw

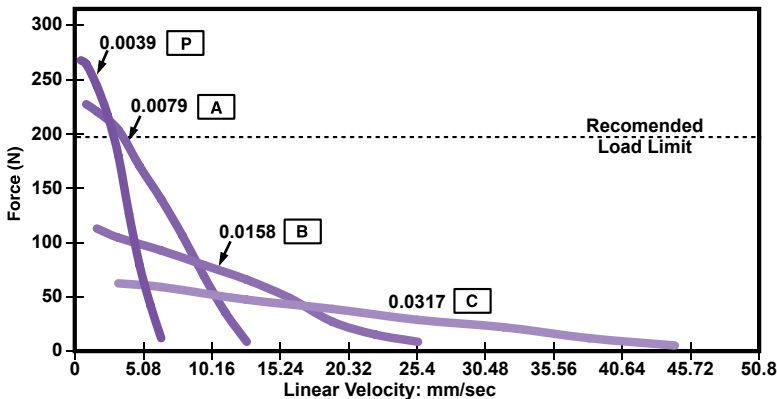

*Care should be taken that the physical load limits of the motor are not exceeded.

Please call for advice when selecting the most appropriate pitch for your application.

NOTE: All Chopper drive curves were generated using a 5 volt motor with a 40 watt power supply. Ramping can increase the performance of a motor either by increasing the top speed or accelerating a heavier load faster. Progressive deceleration can be used to stop the motor without overshoot.

With L/R drives peak force and speeds are reduced, using a unipolar drive will yield a further 30% force reduction.

Contact us for product information, design support and customer solutions

sales@reliance.co.uk

+44 (0) 1484 601002

www.reliance.co.uk

1-69

Actuators



35000 Series

Size 14 High Resolution Linear Actuator Captive Shaft

All dimensions in mm

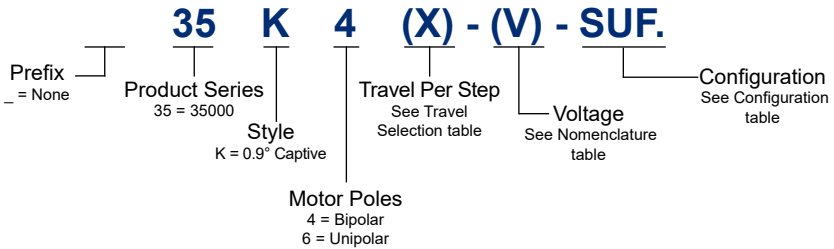
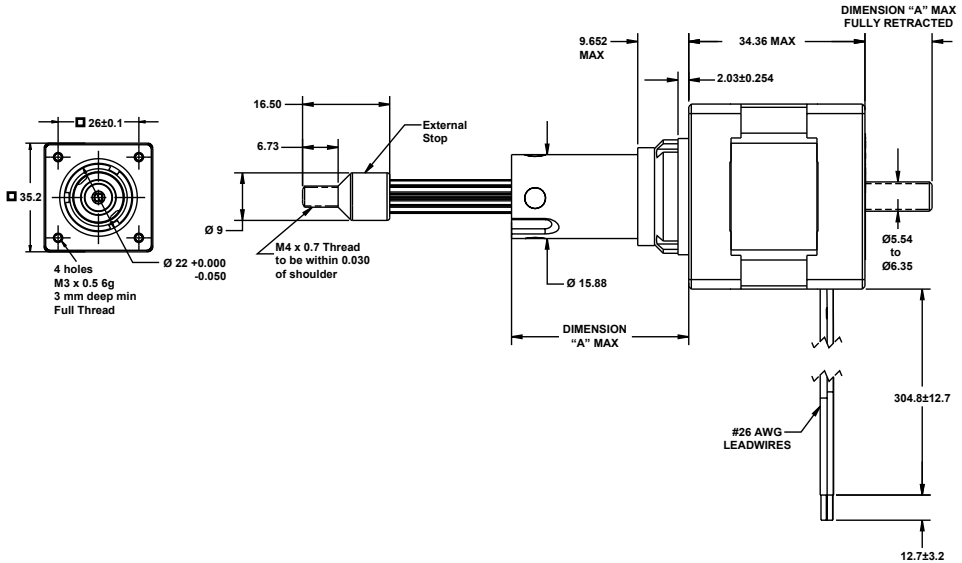

Technical Support

- Selection Guide : Page 1-01
- Product Overview : Page 1-26
- Performance curves : Page 1-76

Actuators



Nomenclature

Size 14 High Res: 35 mm Hybrid Linear Actuator (0.9° Step Angle)						
Part No.	Captive (K)	35K4(X)-(V)-SUF.			35K6-(X)-(V)-SUF.	
Wiring		BIPOLAR (4)			Unipolar** (6)	
Winding Voltage (V)		2.33 VDC	5 VDC	12 VDC	5 VDC	12 VDC
Current (RMS) each phase		125 A	0.57 A	0.24 A	0.57 A	0.24 A
Resistance each phase		1.86Ω	8.8Ω	50.5Ω	8.8Ω	50.5Ω
Inductance each phase		2.8mH	13mH	60mH	6.5mH	30mH

Motor Specification

Size 14 High Res: 35 mm Hybrid Linear Actuator (0.9° Step Angle)	
Power consumption	5.7 W Total
Rotor Inertia	16.0 gcm ²
Insulation Class	Class B (Class F available)
Weight	162g
Insulation Resistance	20MΩ

Standard motors are Class B rated for maximum temperature of 130°C.

Rating modifiers may be necessary when using the shaft fully extended or fully retracted for the whole life cycle.

**Unipolar drive gives approx 30% less thrust than Bipolar.

*Values truncated

Travel Selection

Linear Travel/ Step	0.0015*	0.0030*	0.0060*	0.0121*	0.0243*
Screw Ø5.54 mm					
Part No (X)	U	N	K	J	Q
Linear Travel/Step	0.0020*	0.0039*	0.0079*	0.0158*	
Screw Ø6.35 mm					
Part No (X)	V	P	A	B	

Configuration

Stroke	Dim. "A"	Dim. "B"	SUF.
12.7	20.8	1.0	-905
19.05	27.2	7.4	-907
25.4	33.5	13.7	-910
31.75	39.9	20.1	-912
38.1	46.2	26.4	-915
50.8	58.9	39.1	-920
63.5	71.6	51.8	-925

Further resolutions available on request.

Custom leadscrew lengths are available on request.



35000 Series

Size 14 High Resolution Linear Actuator Non-captive Shaft

All dimensions in mm

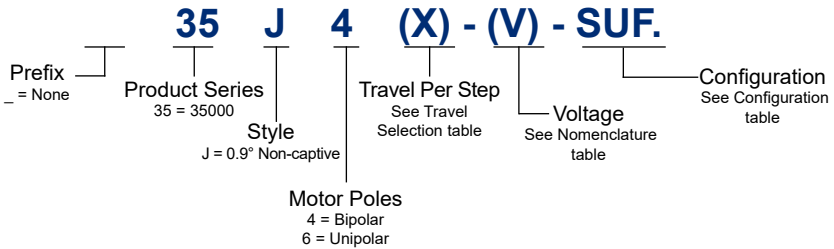
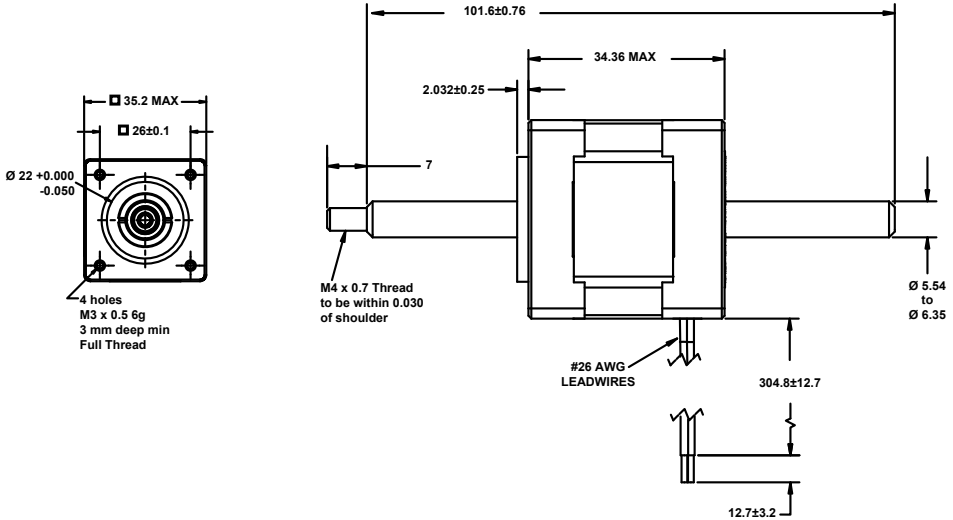

Technical Support

- Selection Guide : Page 1-01
- Product Overview : Page 1-26
- Performance curves : Page 1-76

Actuators



Nomenclature

Size 14 High Res: 35 mm Hybrid Linear Actuator (0.9° Step Angle)						
Part No.	Non-captive (J)	35J4(X)-(V)-SUF.			35J6-(X)-(V)-SUF.	
Wiring		BIPOLAR (4)			Unipolar** (6)	
Winding Voltage (V)		2.33 VDC	5 VDC	12 VDC	5 VDC	12 VDC
Current (RMS) each phase		125 A	0.57 A	0.24 A	0.57 A	0.24 A
Resistance each phase		1.86Ω	8.8Ω	50.5Ω	8.8Ω	50.5Ω
Inductance each phase		2.8mH	13mH	60mH	6.5mH	30mH

Motor Specification

Size 14 High Res: 35 mm Hybrid Linear Actuator (0.9° Step Angle)	
Power consumption	5.7 W Total
Rotor Inertia	16.0 gcm ²
Insulation Class	Class B (Class F available)
Weight	162g
Insulation Resistance	20MΩ

Standard motors are Class B rated for maximum temperature of 130°C.

Rating modifiers may be necessary when using the shaft fully extended or fully retracted for the whole life cycle.

**Unipolar drive gives approx 30% less thrust than Bipolar.

*Values truncated

Travel Selection

Linear Travel/ Step	0.0015*	0.0030*	0.0060*	0.0121*	0.0243*
Screw Ø5.54 mm					
Part No (X)	U	N	K	J	Q
Linear Travel/Step	0.0020*	0.0039*	0.0079*	0.0158*	
Screw Ø6.35 mm					
Part No (X)	V	P	A	B	

Configuration

Further resolutions available on request.

Custom leadscrew lengths are available on request.



35000 Series

Size 14 High Resolution Linear Actuator External Linear

All dimensions in mm

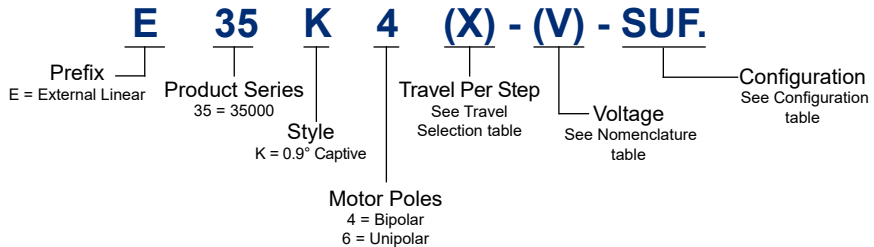
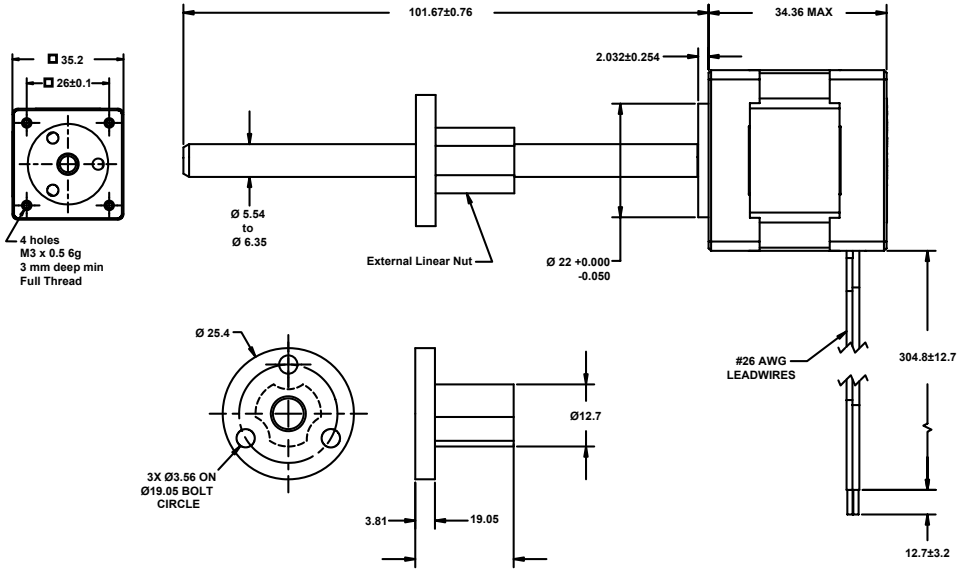

Actuators



Technical Support

- Selection Guide : Page 1-01
- Product Overview : Page 1-26
- Performance curves : Page 1-76



Nomenclature

Size 14 High Res: 35 mm Hybrid Linear Actuator (0.9° Step Angle)						
Part No.	External Linear (EK)	E35K4(X)-(V)-SUF.			E35K6-(X)-(V)-SUF.	
Wiring		BIPOLAR (4)			Unipolar** (6)	
Winding Voltage (V)		2.33 VDC	5 VDC	12 VDC	5 VDC	12 VDC
Current (RMS) each phase		125 A	0.57 A	0.24 A	0.57 A	0.24 A
Resistance each phase		1.86Ω	8.8Ω	50.5Ω	8.8Ω	50.5Ω
Inductance each phase		2.8mH	13mH	60mH	6.5mH	30mH

Motor Specification

Size 14 High Res: 35 mm Hybrid Linear Actuator (0.9° Step Angle)	
Power consumption	5.7 W Total
Rotor Inertia	16.0 gcm ²
Insulation Class	Class B (Class F available)
Weight	162g
Insulation Resistance	20MΩ

Standard motors are Class B rated for maximum temperature of 130°C.

Rating modifiers may be necessary when using the shaft fully extended or fully retracted for the whole life cycle.

**Unipolar drive gives approx 30% less thrust than Bipolar.

*Values truncated

Travel Selection

Linear Travel/ Step	0.0015*	0.0030*	0.0060*	0.0121*	0.0243*
Screw Ø5.54 mm					
Part No (X)	U	N	K	J	Q
Linear Travel/Step	0.0020*	0.0039*	0.0079*	0.0158*	
Screw Ø6.35 mm					
Part No (X)	V	P	A	B	

Configuration

Further resolutions available on request.

Custom leadscrew lengths are available on request.



Force vs. Pulse Rate

Bipolar. Chopper. 100% Duty Cycle
Ø 5.54 mm and Ø 6.35 mm Lead-screw

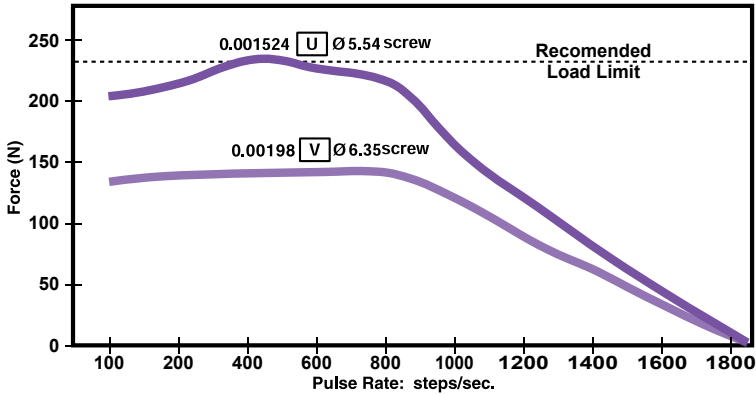

Force vs. Linear Velocity

Bipolar. Chopper. 100% Duty Cycle
Ø 5.54 mm and Ø 6.35 mm Lead-screw

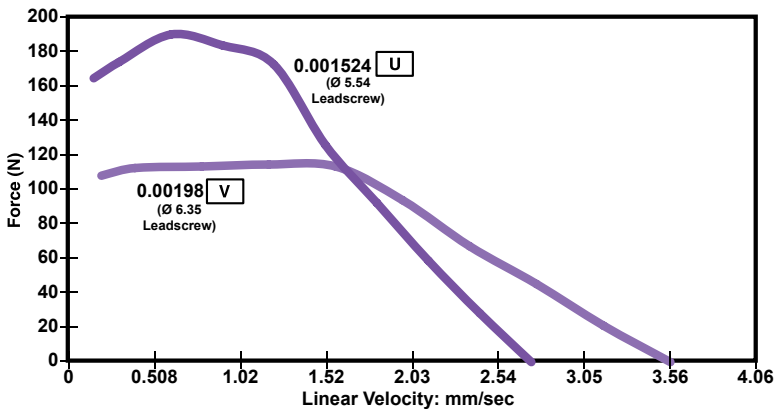

*Care should be taken that the physical load limits of the motor are not exceeded.

Please call for advice when selecting the most appropriate pitch for your application.

NOTE: All Chopper drive curves were generated using a 5 volt motor with a 40 watt power supply. Ramping can increase the performance of a motor either by increasing the top speed or accelerating a heavier load faster. Progressive deceleration can be used to stop the motor without overshoot.

With L/R drives peak force and speeds are reduced, using a unipolar drive will yield a further 30% force reduction.

Actuators



All dimensions in mm

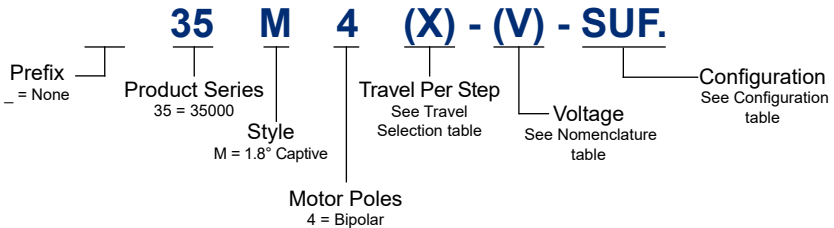
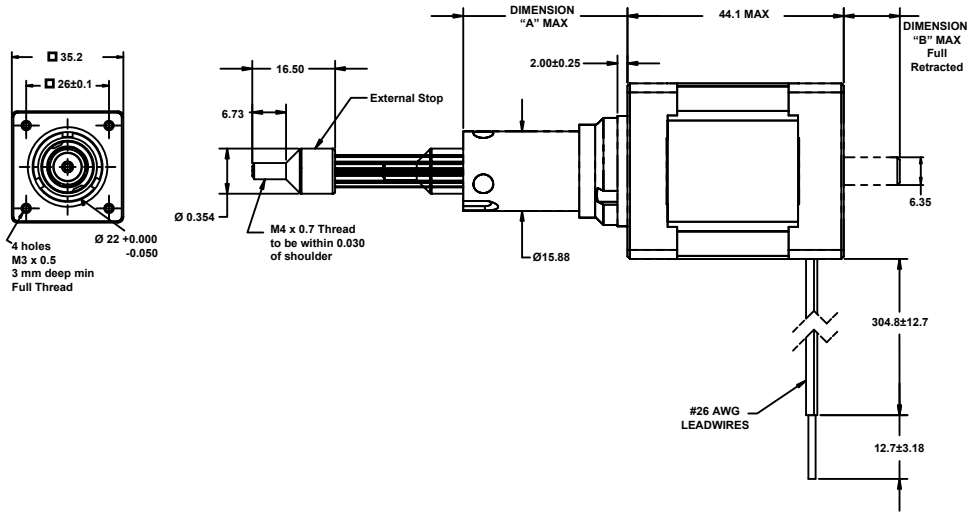

Technical Support

- Selection Guide : Page 1-01
- Product Overview : Page 1-26
- Performance curves : Page 1-84



Nomenclature

Size 14 Double Stack: 35 mm Hybrid Linear Actuator (1.8° Step Angle)			
Part No.	Captive (M)	35M4(X)-(V)-SUF.	
Wiring		BIPOLAR (4)	
Winding Voltage (V)	2.33 VDC	5 VDC	12 VDC
Current (RMS) each phase	2 A	910 mA	380 mA
Resistance each phase	1.2Ω	5.5Ω	31.6Ω
Inductance each phase	1.95mH	7.63mH	65.1mH

Motor Specification

Size 14 Double Stack: 35 mm Hybrid Linear Actuator (1.8° Step Angle)	
Power consumption	9.1 W Total
Rotor Inertia	30 gcm ²
Insulation Class	Class B (Class F available)
Weight	240g
Insulation Resistance	20MΩ

Standard motors are Class B rated for maximum temperature of 130°C.

Rating modifiers may be necessary when using the shaft fully extended or fully retracted for the whole life cycle.

*Values truncated

Travel Selection

Linear Travel/ Step	0.0158*	0.0317*	0.0635	0.0953	0.0127
Screw Ø5.54 mm					
Part No (X)	B	C	Y	AG	Z

Configuration

Stroke	Dim. "A"	Dim. "B"	SUF.
12.7	20.8	1.0	-905
19.05	27.2	7.4	-907
25.4	33.5	13.7	-910
31.75	39.9	20.1	-912
38.1	46.2	26.4	-915
50.8	58.9	39.1	-920
63.5	71.6	51.8	-925

Further resolutions available on request.

Custom leadscrew lengths are available on request.



35000 Series

Size 14 Double Stack Linear Actuator Non-captive Shaft

All dimensions in mm

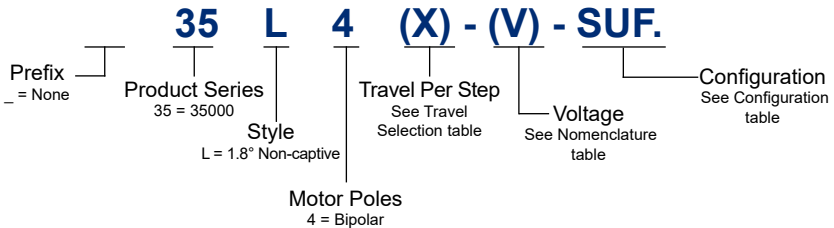
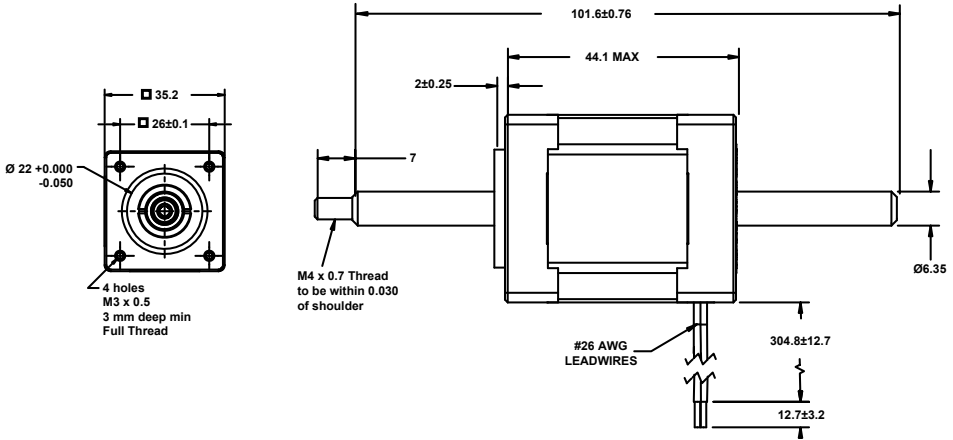

Technical Support

- Selection Guide : Page 1-01
- Product Overview : Page 1-26
- Performance curves : Page 1-84

Actuators



Nomenclature

Size 14 Double Stack: 35 mm Hybrid Linear Actuator (1.8° Step Angle)				
Part No.	Non-captive (L)	35L4(X)-(V)-SUF.		
Wiring		BIPOLAR (4)		
Winding Voltage (V)		2.33 VDC	5 VDC	12 VDC
Current (RMS) each phase		2 A	910 mA	380 mA
Resistance each phase		1.2Ω	5.5Ω	31.6Ω
Inductance each phase		1.95mH	7.63mH	65.1mH

Motor Specification

Size 14 Double Stack: 35 mm Hybrid Linear Actuator (1.8° Step Angle)	
Power consumption	9.1 W Total
Rotor Inertia	30 gcm ²
Insulation Class	Class B (Class F available)
Weight	240g
Insulation Resistance	20MΩ

Standard motors are Class B rated for maximum temperature of 130°C.

Rating modifiers may be necessary when using the shaft fully extended or fully retracted for the whole life cycle.

*Values truncated

Travel Selection

Linear Travel/ Step	0.0158*	0.0317*	0.0635	0.0953	0.0127
Screw Ø5.54 mm					
Part No (X)	B	C	Y	AG	Z

Configuration

Further resolutions available on request.

Custom leadscrew lengths are available on request.



All dimensions in mm

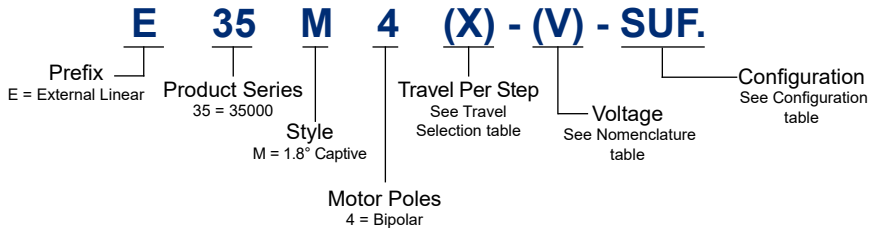
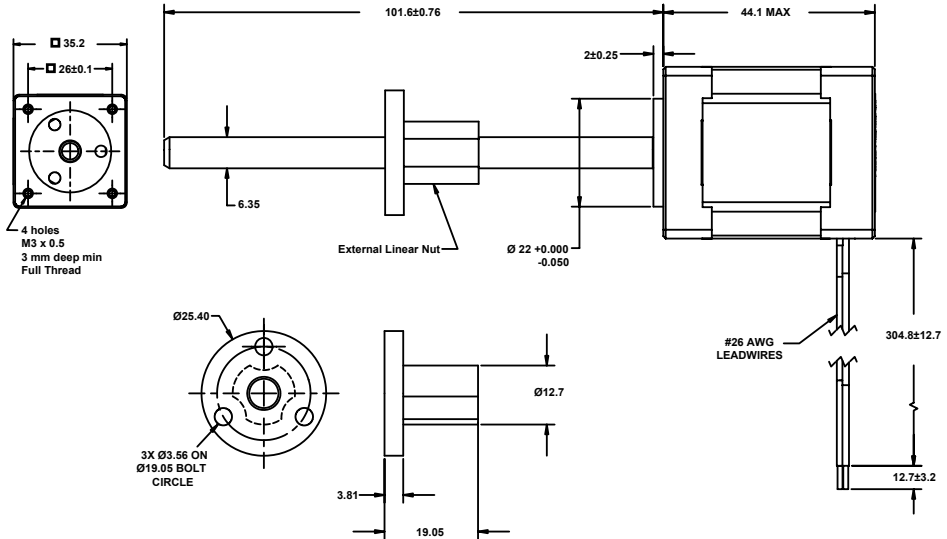

Technical Support

- Selection Guide : Page 1-01
- Product Overview : Page 1-26
- Performance curves : Page 1-84

Actuators



Nomenclature

Size 14 Double Stack: 35 mm Hybrid Linear Actuator (1.8° Step Angle)			
Part No.	External Linear (EM)	E35M4(X)-(V)-SUF.	
Wiring		BIPOLAR (4)	
Winding Voltage (V)	2.33 VDC	5 VDC	12 VDC
Current (RMS) each phase	2 A	910 mA	380 mA
Resistance each phase	1.2Ω	5.5Ω	31.6Ω
Inductance each phase	1.95mH	7.63mH	65.1mH

Motor Specification

Size 14 Double Stack: 35 mm Hybrid Linear Actuator (1.8° Step Angle)	
Power consumption	9.1 W Total
Rotor Inertia	30 gcm ²
Insulation Class	Class B (Class F available)
Weight	240g
Insulation Resistance	20MΩ

Standard motors are Class B rated for maximum temperature of 130°C.

Rating modifiers may be necessary when using the shaft fully extended or fully retracted for the whole life cycle.

*Values truncated

Travel Selection

Linear Travel/ Step	0.0158*	0.0317*	0.0635	0.0953	0.0127
Screw Ø5.54 mm					
Part No (X)	B	C	Y	AG	Z

Configuration

Further resolutions available on request.

Custom leadscrew lengths are available on request.



Force vs. Pulse Rate Bipolar. Chopper. 100% Duty Cycle
Ø 6.35 mm Lead-screw

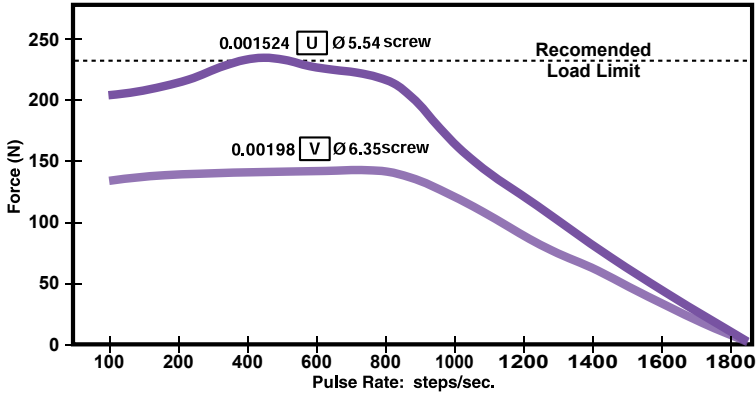

Force vs. Linear Velocity Bipolar. Chopper. 100% Duty Cycle
Ø 6.35 mm Lead-screw

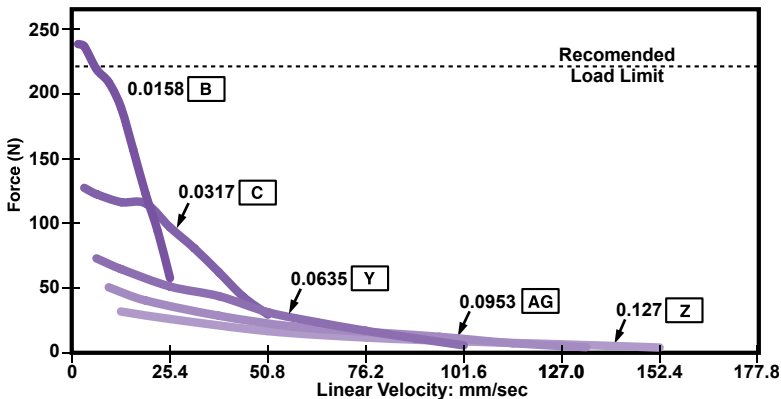

*Care should be taken that the physical load limits of the motor are not exceeded.

Please call for advice when selecting the most appropriate pitch for your application.

NOTE: All Chopper drive curves were generated using a 5 volt motor with a 40 watt power supply. Ramping can increase the performance of a motor either by increasing the top speed or accelerating a heavier load faster. Progressive deceleration can be used to stop the motor without overshoot.

With L/R drives peak force and speeds are reduced, using a unipolar drive will yield a further 30% force reduction.

Actuators

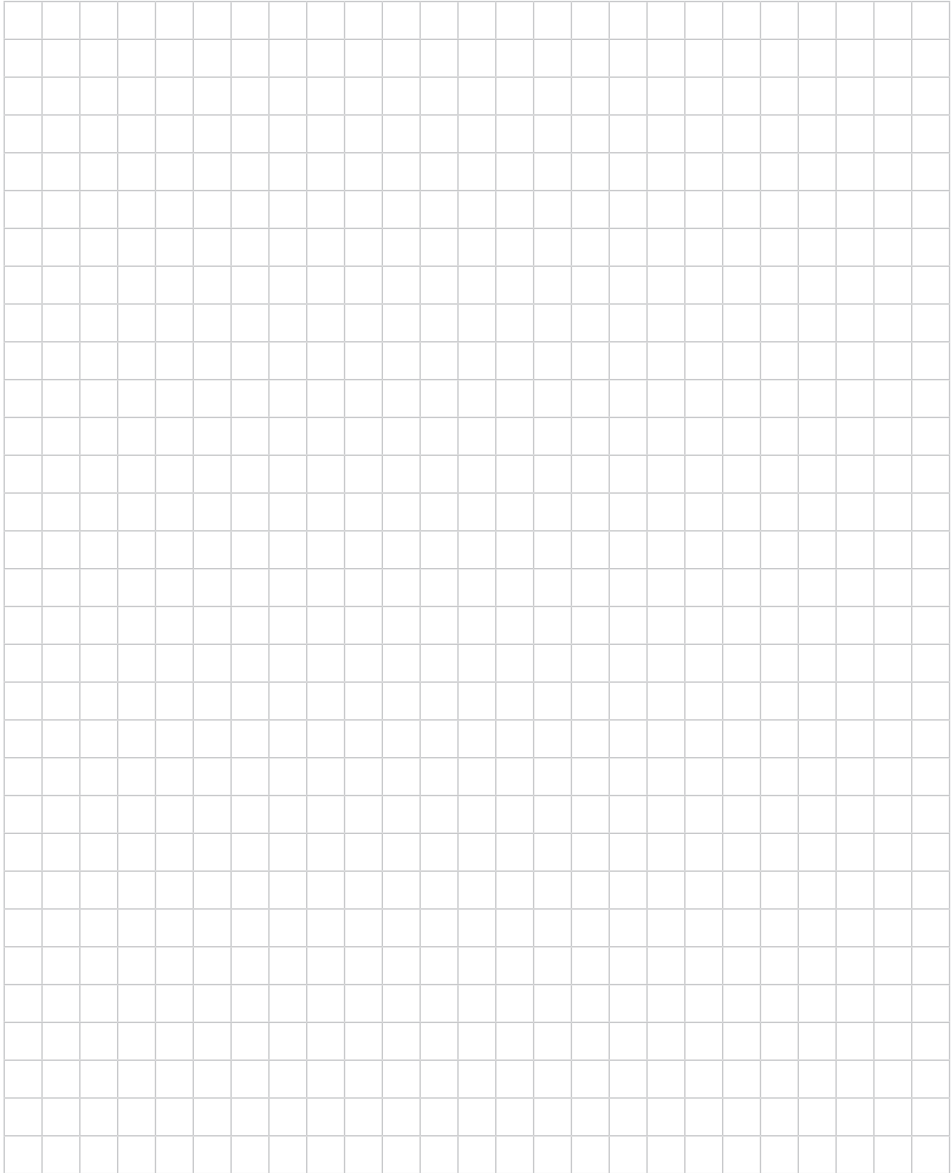



All dimensions in mm

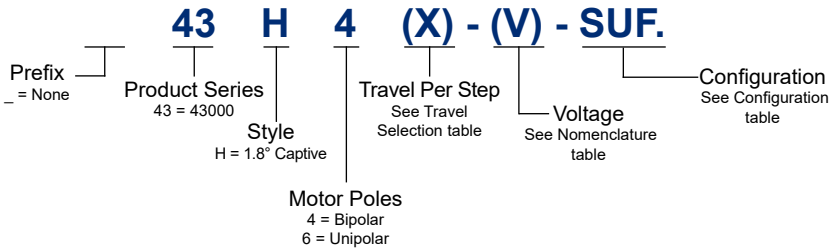
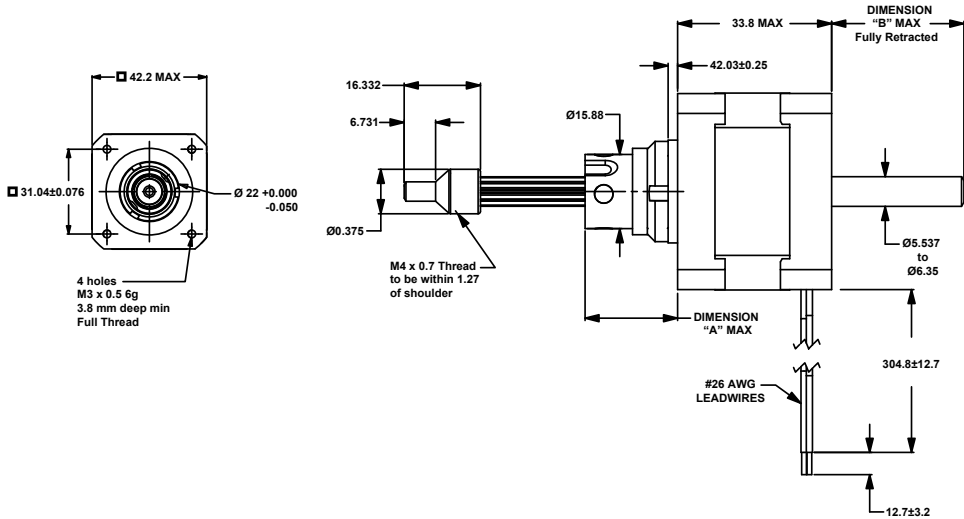

Technical Support

- Selection Guide : Page 1-01
- Product Overview : Page 1-26
- Performance curves : Page 1-92



Nomenclature

Size 17: 43 mm Hybrid Linear Actuator (1.8° Step Angle)						
Part No.	Captive (H)	43H4(X)-(V)-SUF.			43H6-(X)-(V)-SUF.	
Wiring		BIPOLAR (4)			Unipolar** (6)	
Winding Voltage (V)		2.33 VDC	5 VDC	12 VDC	5 VDC	12 VDC
Current (RMS) each phase		1.5 A	700 mA	290 mA	700 mA	290 mA
Resistance each phase		1.56Ω	7.2Ω	41.5Ω	7.2Ω	41.5Ω
Inductance each phase		1.9mH	8.7mH	54.0mH	4.4mH	27.0mH

Motor Specification

Size 17: 43 mm Hybrid Linear Actuator (1.8° Step Angle)	
Power consumption	7.0 W Total
Rotor Inertia	37.0 gcm ²
Insulation Class	Class B (Class F available)
Weight	241g
Insulation Resistance	20MΩ

Standard motors are Class B rated for maximum temperature of 130°C.

Rating modifiers may be necessary when using the shaft fully extended or fully retracted for the whole life cycle.

**Unipolar drive gives approx 30% less thrust than Bipolar.

*Values truncated

Travel Selection

Linear Travel/ Step	0.0030*	0.0060*	0.0121*	0.0243*	0.0487*
Screw Ø5.54 mm					
Part No (X)	N	K	J	Q	R
Linear Travel/Step	0.0039*	0.0079*	0.0158*	0.0317*	
Screw Ø6.35 mm					
Part No (X)	P	A	B	C	

Configuration

Stroke	Dim. "A"	Dim. "B"	SUF.	M4x0.7 Thread
12.7	19.8	4.1	-905	-805
19.05	26.2	10.4	-907	-807
25.4	32.5	16.8	-910	-810
31.75	38.9	23.1	-912	-812
38.1	45.2	29.5	-915	-815
50.8	57.9	42.2	-920	-820
63.5	70.6	54.9	-925	-825

Further resolutions available on request.

Custom leadscrew lengths are available on request.



43000 Series

Size 17 Linear Actuator Non-captive Shaft

All dimensions in mm

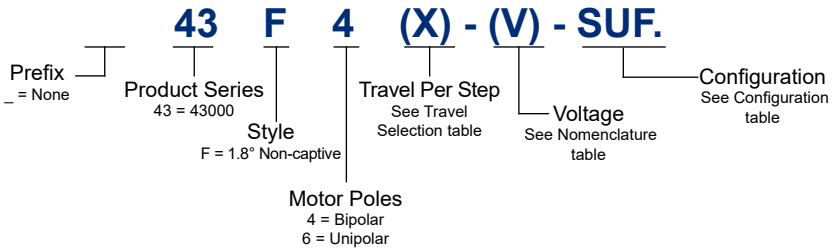
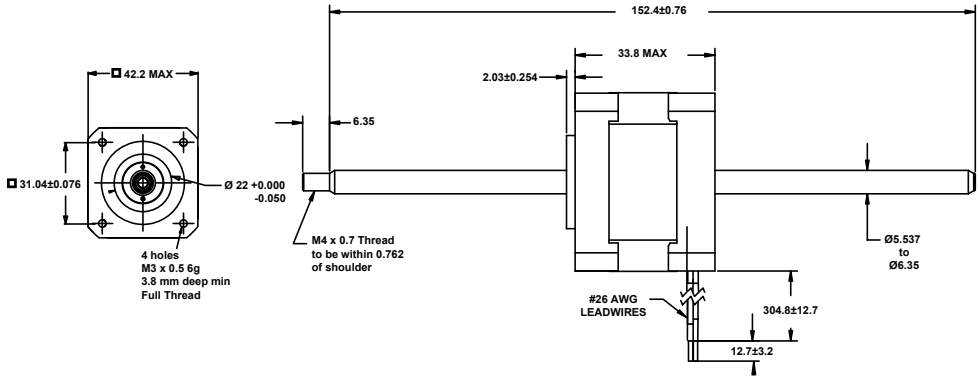

Technical Support

- Selection Guide : Page 1-01
- Product Overview : Page 1-26
- Performance curves : Page 1-92

Actuators



Nomenclature

Size 17: 43 mm Hybrid Linear Actuator (1.8° Step Angle)						
Part No.	Non-captive (F)	43F4(X)-(V)-SUF.			43F6-(X)-(V)-SUF.	
Wiring		BIPOLAR (4)			Unipolar** (6)	
Winding Voltage (V)		2.33 VDC	5 VDC	12 VDC	5 VDC	12 VDC
Current (RMS) each phase		1.5 A	700 mA	290 mA	700 mA	290 mA
Resistance each phase		1.56Ω	7.2Ω	41.5Ω	7.2Ω	41.5Ω
Inductance each phase		1.9mH	8.7mH	54.0mH	4.4mH	27.0mH

Motor Specification

Size 17: 43 mm Hybrid Linear Actuator (1.8° Step Angle)	
Power consumption	7.0 W Total
Rotor Inertia	37.0 gcm ²
Insulation Class	Class B (Class F available)
Weight	241g
Insulation Resistance	20MΩ

Standard motors are Class B rated for maximum temperature of 130°C.

Rating modifiers may be necessary when using the shaft fully extended or fully retracted for the whole life cycle.

**Unipolar drive gives approx 30% less thrust than Bipolar.

*Values truncated

Travel Selection

Linear Travel/ Step	0.0030*	0.0060*	0.0121*	0.0243*	0.0487*
Screw Ø5.54 mm					
Part No (X)	N	K	J	Q	R
Linear Travel/Step	0.0039*	0.0079*	0.0158*	0.0317*	
Screw Ø6.35 mm					
Part No (X)	P	A	B	C	

Configuration

Further resolutions available on request.

Custom leadscrew lengths are available on request.



All dimensions in mm

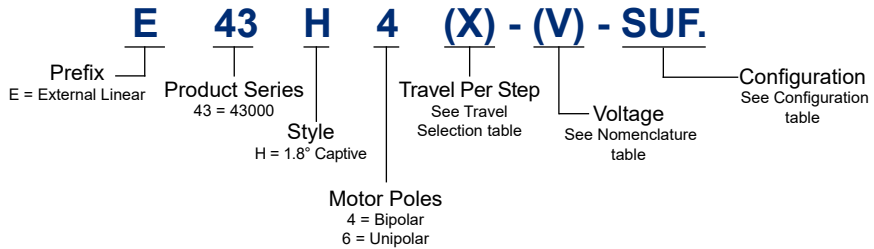
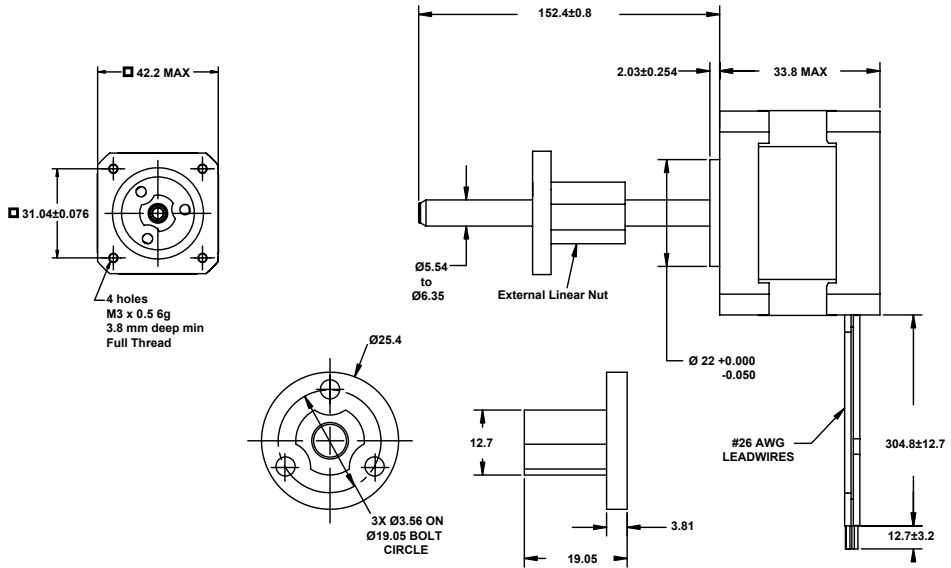

Technical Support

- Selection Guide : Page 1-01
- Product Overview : Page 1-26
- Performance curves : Page 1-92



Nomenclature

Size 17: 43 mm Hybrid Linear Actuator (1.8° Step Angle)						
Part No.	External Linear (EH)	E43H4(X)-(V)-SUF.			E43H6(X)-(V)-SUF.	
Wiring		BIPOLAR (4)			Unipolar** (6)	
Winding Voltage (V)		2.33 VDC	5 VDC	12 VDC	5 VDC	12 VDC
Current (RMS) each phase		1.5 A	700 mA	290 mA	700 mA	290 mA
Resistance each phase		1.56Ω	7.2Ω	41.5Ω	7.2Ω	41.5Ω
Inductance each phase		1.9mH	8.7mH	54.0mH	4.4mH	27.0mH

Motor Specification

Size 17: 43 mm Hybrid Linear Actuator (1.8° Step Angle)	
Power consumption	7.0 W Total
Rotor Inertia	37.0 gcm ²
Insulation Class	Class B (Class F available)
Weight	241g
Insulation Resistance	20MΩ

Standard motors are Class B rated for maximum temperature of 130°C.

Rating modifiers may be necessary when using the shaft fully extended or fully retracted for the whole life cycle.

**Unipolar drive gives approx 30% less thrust than Bipolar.

*Values truncated

Travel Selection

Linear Travel/ Step	0.0030*	0.0060*	0.0121*	0.0243*	0.0487*
Screw Ø5.54 mm					
Part No (X)	N	K	J	Q	R
Linear Travel/Step	0.0039*	0.0079*	0.0158*	0.0317*	
Screw Ø6.35 mm					
Part No (X)	P	A	B	C	

Configuration

Further resolutions available on request.

Custom leadscrew lengths are available on request.



Force vs. Pulse Rate Bipolar. Chopper. 100% Duty Cycle
Ø 5.54 mm Lead-screw

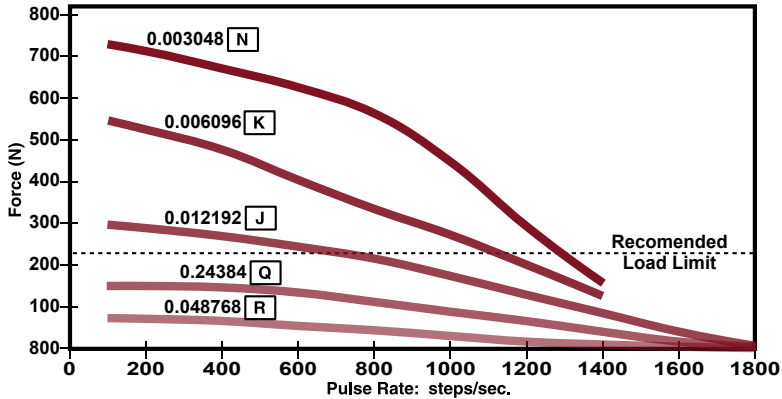

Ø 6.35 mm Lead-screw

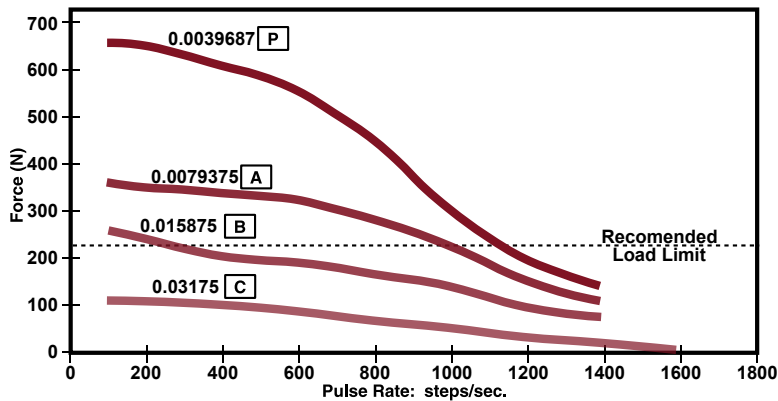

Size 17 Linear Actuator Performance Curves

43000 Series



Force vs. Linear Velocity

Bipolar. Chopper. 100% Duty Cycle

Ø 5.54 mm Lead-screw

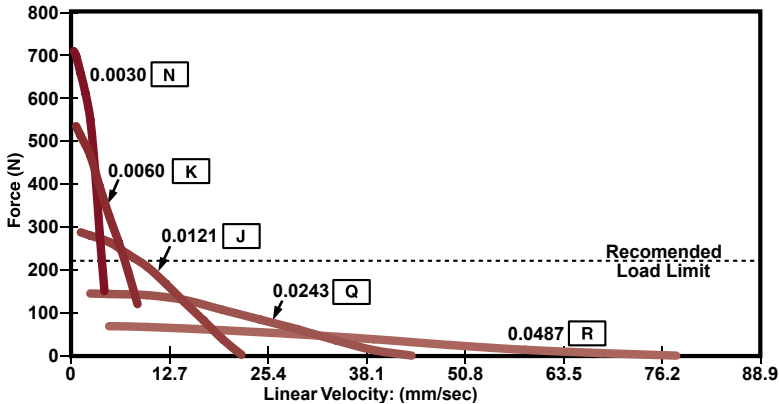

Ø 6.35 mm Lead-screw

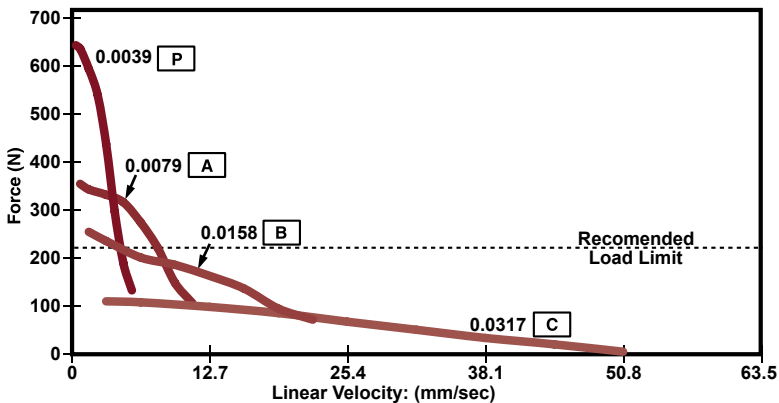

*Care should be taken that the physical load limits of the motor are not exceeded.

Please call for advice when selecting the most appropriate pitch for your application.

NOTE: All Chopper drive curves were generated using a 5 volt motor with a 40 volt power supply. Ramping can increase the performance of a motor either by increasing the top speed or accelerating a heavier load faster. Progressive deceleration can be used to stop the motor without overshoot.

With L/R drives peak force and speeds are reduced, using a unipolar drive will yield a further 30% force reduction.



All dimensions in mm

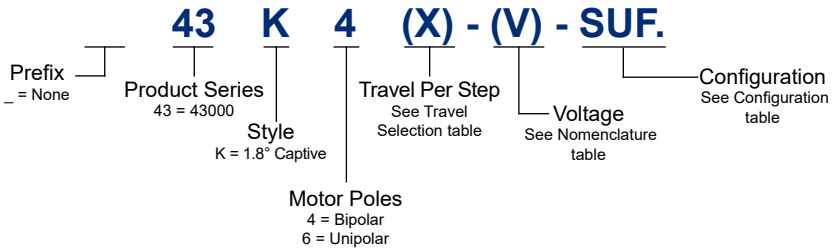
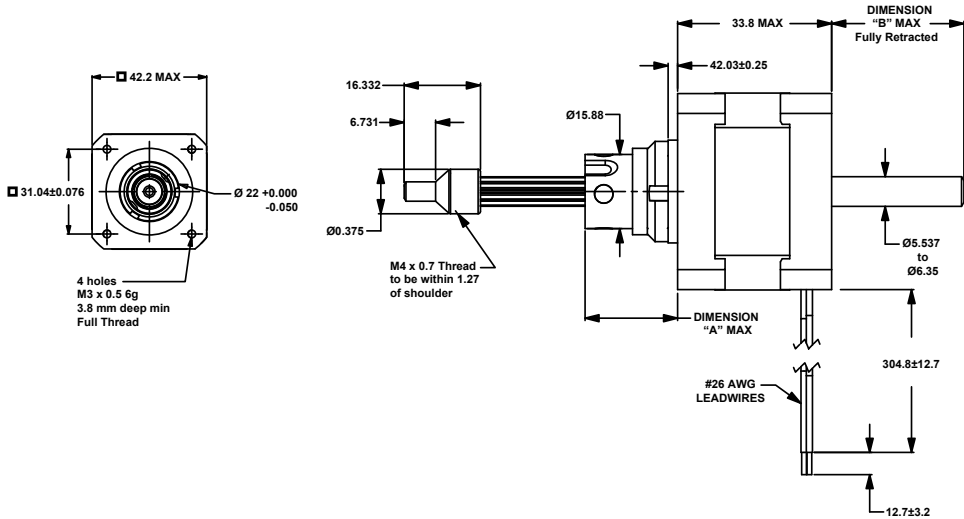

Technical Support

- Selection Guide : Page 1-01
- Product Overview : Page 1-26
- Performance curves : Page 1-100



Nomenclature

Size 17 High Res: 43 mm Hybrid Linear Actuator (1.8° Step Angle)						
Part No.	Captive (K)	43K4(X)-(V)-SUF.			43K6-(X)-(V)-SUF.	
Wiring		BIPOLAR (4)			Unipolar** (6)	
Winding Voltage (V)		2.33 VDC	5 VDC	12 VDC	5 VDC	12 VDC
Current (RMS) each phase		1.5 A	700 mA	290 mA	700 mA	290 mA
Resistance each phase		1.56Ω	7.2Ω	41.5Ω	7.2Ω	41.5Ω
Inductance each phase		2.6mH	12.0mH	70.0mH	6.0mH	35.0mH

Motor Specification

Size 17 High Res: 43 mm Hybrid Linear Actuator (1.8° Step Angle)	
Power consumption	7.0 W Total
Rotor Inertia	37.0 gcm ²
Insulation Class	Class B (Class F available)
Weight	241g
Insulation Resistance	20MΩ

Standard motors are Class B rated for maximum temperature of 130°C.

Rating modifiers may be necessary when using the shaft fully extended or fully retracted for the whole life cycle.

**Unipolar drive gives approx 30% less thrust than Bipolar.

*Values truncated

Travel Selection

Linear Travel/ Step	0.0015*	0.0030*	0.0060*	0.0121*	0.0243*
Screw Ø5.54 mm					
Part No (X)	U	N	K	J	Q
Linear Travel/Step	0.0020*	0.0039*	0.0079*	0.0158*	
Screw Ø6.35 mm					
Part No (X)	V	P	A	B	

Configuration

Stroke	Dim. "A"	Dim. "B"	SUF.	M4x0.7 Thread
12.7	19.8	4.1	-905	-805
19.05	26.2	10.4	-907	-807
25.4	32.5	16.8	-910	-810
31.75	38.9	23.1	-912	-812
38.1	45.2	29.5	-915	-815
50.8	57.9	42.2	-920	-820
63.5	70.6	54.9	-925	-825

Further resolutions available on request.

Custom leadscrew lengths are available on request.



43000 Series

Size 17 High Resolution Linear Actuator Non-captive Shaft

All dimensions in mm

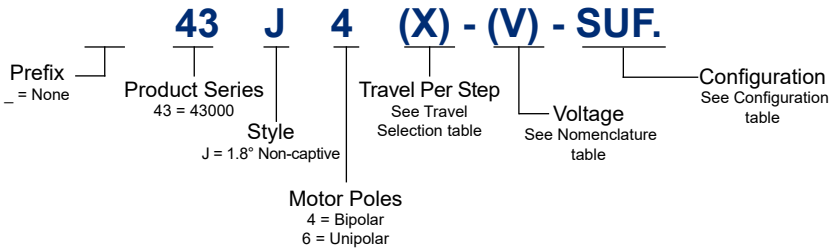
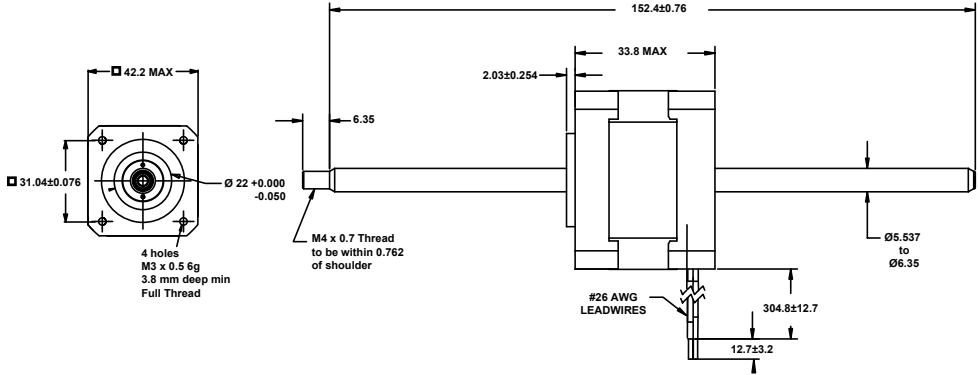

Technical Support

- Selection Guide : Page 1-01
- Product Overview : Page 1-26
- Performance curves : Page 1-100

Actuators



Nomenclature

Size 17 High Res: 43 mm Hybrid Linear Actuator (1.8° Step Angle)					
Part No.	Non-captive (J)	43J4(X)-(V)-SUF.			43J6-(X)-(V)-SUF.
Wiring		BIPOLAR (4)			Unipolar** (6)
Winding Voltage (V)		2.33 VDC	5 VDC	12 VDC	5 VDC 12 VDC
Current (RMS) each phase		1.5 A	700 mA	290 mA	700 mA 290 mA
Resistance each phase		1.56Ω	7.2Ω	41.5Ω	7.2Ω 41.5Ω
Inductance each phase		2.6mH	12.0mH	70.0mH	6.0mH 35.0mH

Motor Specification

Size 17 High Res: 43 mm Hybrid Linear Actuator (1.8° Step Angle)	
Power consumption	7.0 W Total
Rotor Inertia	37.0 gcm ²
Insulation Class	Class B (Class F available)
Weight	241g
Insulation Resistance	20MΩ

Standard motors are Class B rated for maximum temperature of 130°C.

Rating modifiers may be necessary when using the shaft fully extended or fully retracted for the whole life cycle.

**Unipolar drive gives approx 30% less thrust than Bipolar.

*Values truncated

Travel Selection

Linear Travel/ Step	0.0015*	0.0030*	0.0060*	0.0121*	0.0243*
Screw Ø5.54 mm					
Part No (X)	U	N	K	J	Q
Linear Travel/Step	0.0020*	0.0039*	0.0079*	0.0158*	
Screw Ø6.35 mm					
Part No (X)	V	P	A	B	

Configuration

Further resolutions available on request.

Custom leadscrew lengths are available on request.



43000 Series

Size 17 High Resolution Linear Actuator External Linear

All dimensions in mm

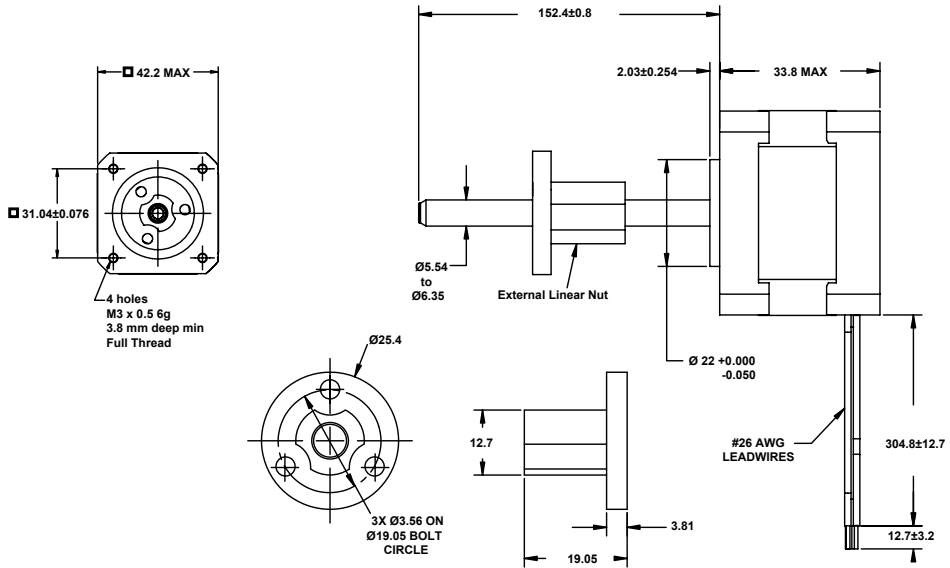

E 43 K 4 (X) - (V) - SUF.

Prefix: E = External Linear
 Product Series: 43 = 43000
 Style: K = 1.8° Captive
 Motor Poles: 4 = Bipolar, 6 = Unipolar
 Travel Per Step: See Travel Selection table
 Voltage: See Nomenclature table
 Configuration: See Configuration table



Technical Support

- Selection Guide : Page 1-01
- Product Overview : Page 1-26
- Performance curves : Page 1-100

Actuators



Nomenclature

Size 17 High Res: 43 mm Hybrid Linear Actuator (1.8° Step Angle)						
Part No.	External Linear (EK)	E43K4(X)-(V)-SUF.			E43K6-(X)-(V)-SUF.	
Wiring		BIPOLAR (4)			Unipolar** (6)	
Winding Voltage (V)		2.33 VDC	5 VDC	12 VDC	5 VDC	12 VDC
Current (RMS) each phase		1.5 A	700 mA	290 mA	700 mA	290 mA
Resistance each phase		1.56Ω	7.2Ω	41.5Ω	7.2Ω	41.5Ω
Inductance each phase		2.6mH	12.0mH	70.0mH	6.0mH	35.0mH

Motor Specification

Size 17 High Res: 43 mm Hybrid Linear Actuator (1.8° Step Angle)	
Power consumption	7.0 W Total
Rotor Inertia	37.0 gcm ²
Insulation Class	Class B (Class F available)
Weight	241g
Insulation Resistance	20MΩ

Standard motors are Class B rated for maximum temperature of 130°C.

Rating modifiers may be necessary when using the shaft fully extended or fully retracted for the whole life cycle.

**Unipolar drive gives approx 30% less thrust than Bipolar.

*Values truncated

Travel Selection

Linear Travel/ Step	0.0015*	0.0030*	0.0060*	0.0121*	0.0243*
Screw Ø5.54 mm					
Part No (X)	U	N	K	J	Q
Linear Travel/Step	0.0020*	0.0039*	0.0079*	0.0158*	
Screw Ø6.35 mm					
Part No (X)	V	P	A	B	

Configuration

Further resolutions available on request.

Custom leadscrew lengths are available on request.



Force vs. Pulse Rate Bipolar. Chopper. 100% Duty Cycle
Ø 5.54 mm and Ø 6.35 mm Lead-screw

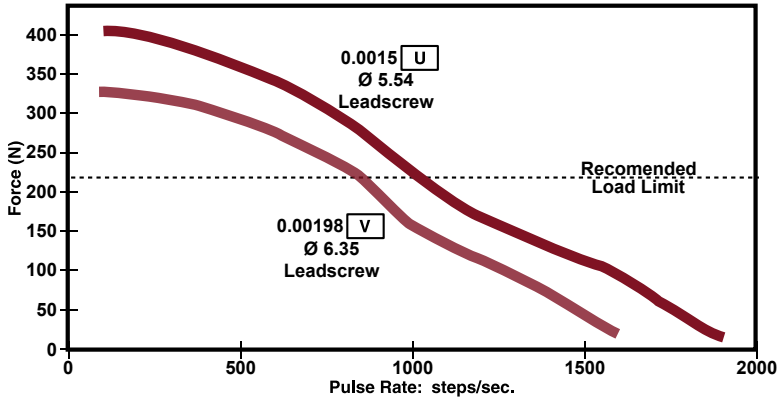

Force vs. Linear Velocity Bipolar. Chopper. 100% Duty Cycle
Ø 5.54 mm and Ø 6.35 mm Lead-screw

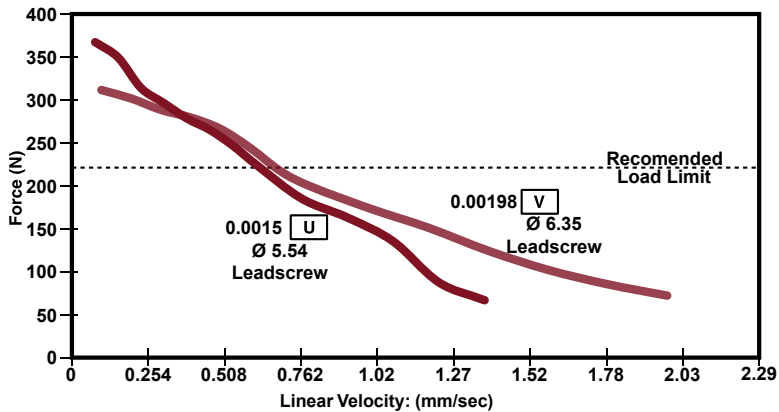

*Care should be taken that the physical load limits of the motor are not exceeded.

Please call for advice when selecting the most appropriate pitch for your application.

NOTE: All Chopper drive curves were generated using a 5 volt motor with a 40 watt power supply. Ramping can increase the performance of a motor either by increasing the top speed or accelerating a heavier load faster. Progressive deceleration can be used to stop the motor without overshoot.

With L/R drives peak force and speeds are reduced, using a unipolar drive will yield a further 30% force reduction.

Actuators

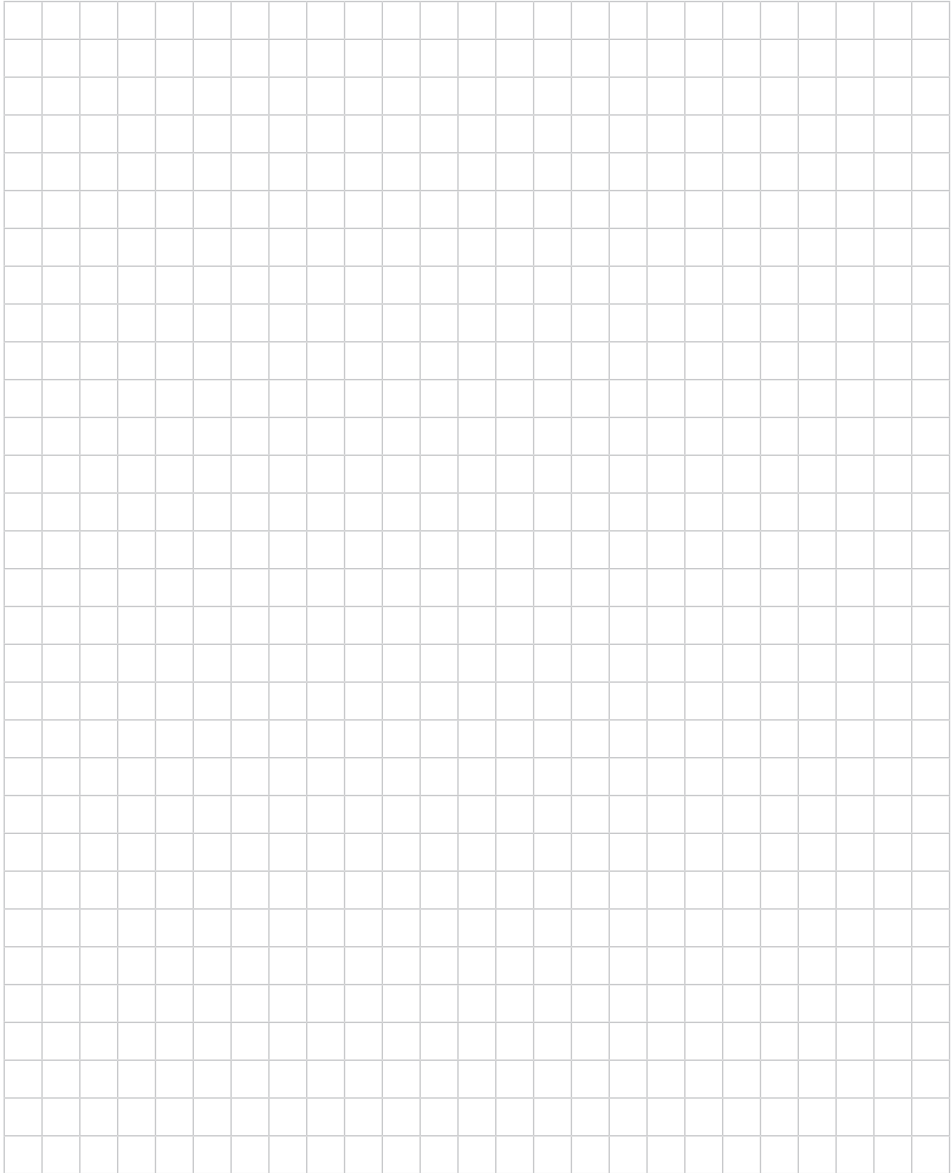



All dimensions in mm

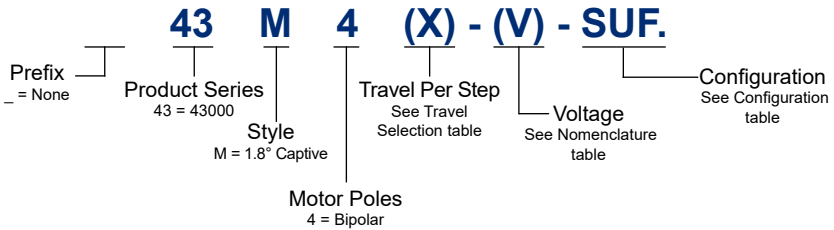
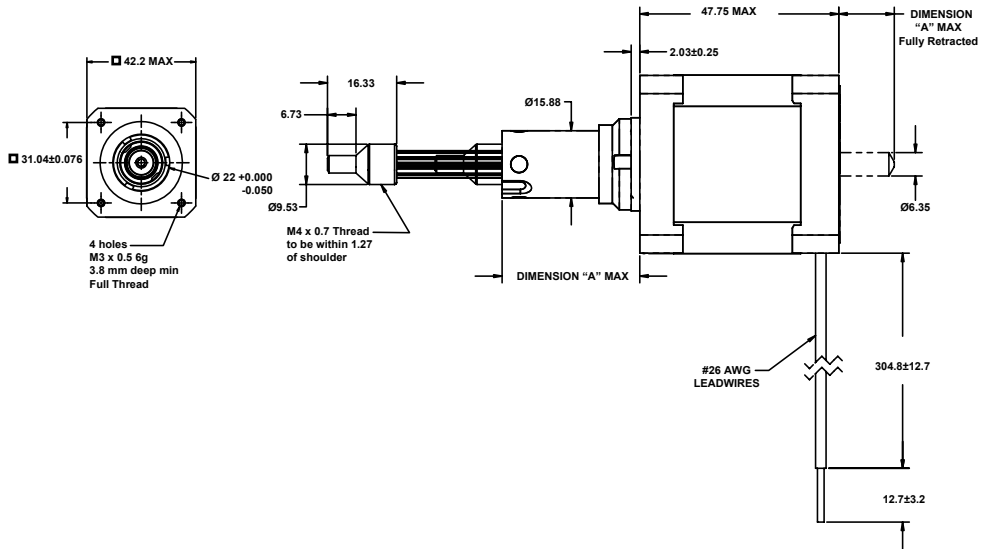

Technical Support

- Selection Guide : Page 1-01
- Product Overview : Page 1-26
- Performance curves : Page 1-108



Nomenclature

Size 17 Double Stack: 43 mm Hybrid Linear Actuator (1.8° Step Angle)				
Part No.	Captive (M)	43M4(X)-(V)-SUF.		
Wiring		BIPOLAR (4)		
Winding Voltage (V)	2.33 VDC	5 VDC	12 VDC	
Current (RMS) each phase	1.5 A	1.3 A	550 mA	
Resistance each phase	0.9Ω	3.8Ω	21.9Ω	
Inductance each phase	1.33mH	8.21mH	45.1mH	

Motor Specification

Size 17 Double Stack: 43 mm Hybrid Linear Actuator (1.8° Step Angle)	
Power consumption	10.4 W Total
Rotor Inertia	78.0 gcm ²
Insulation Class	Class B (Class F available)
Weight	352g
Insulation Resistance	20MΩ

Standard motors are Class B rated for maximum temperature of 130°C.

Rating modifiers may be necessary when using the shaft fully extended or fully retracted for the whole life cycle.

*Values truncated

Travel Selection

Linear Travel/ Step	0.0158*	0.0317*	0.0635	0.0953	0.127
Screw Ø5.54 mm					
Part No (X)	B	C	Y	AG	Z

Configuration

Stroke	Dim. "A"	Dim. "B"	SUF.	M4x0.7 Thread
12.7	19.8	0.51	-905	-805
19.05	26.2	6.86	-907	-807
25.4	32.5	13.21	-910	-810
31.75	38.9	19.56	-912	-812
38.1	45.2	25.91	-915	-815
50.8	57.9	38.61	-920	-820
63.5	70.6	51.31	-925	-825

Further resolutions available on request.

Custom leadscrew lengths are available on request.



All dimensions in mm

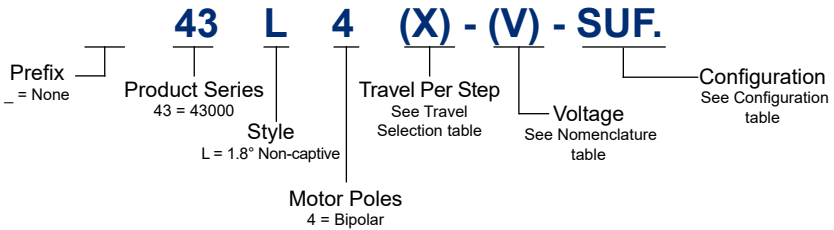
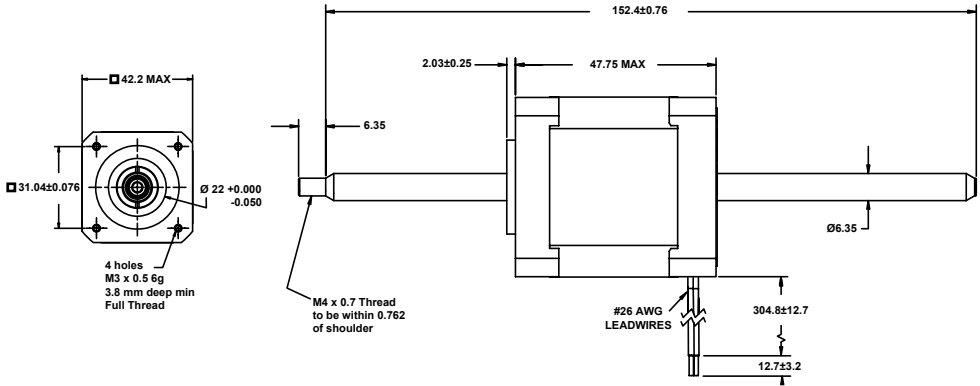

Technical Support

- Selection Guide : Page 1-01
- Product Overview : Page 1-26
- Performance curves : Page 1-108

Size 17 Double Stack Linear Actuator Non-captive Shaft

43000 Series



Nomenclature

Size 17 Double Stack: 43 mm Hybrid Linear Actuator (1.8° Step Angle)				
Part No.	Non-captive (L)	43L4(X)-(V)-SUF.		
Wiring		BIPOLAR (4)		
Winding Voltage (V)	2.33 VDC	5 VDC	12 VDC	
Current (RMS) each phase	1.5 A	1.3 A	550 mA	
Resistance each phase	0.9Ω	3.8Ω	21.9Ω	
Inductance each phase	1.33mH	8.21mH	45.1mH	

Motor Specification

Size 17 Double Stack: 43 mm Hybrid Linear Actuator (1.8° Step Angle)	
Power consumption	10.4 W Total
Rotor Inertia	78.0 gcm ²
Insulation Class	Class B (Class F available)
Weight	352g
Insulation Resistance	20MΩ

Standard motors are Class B rated for maximum temperature of 130°C.

Rating modifiers may be necessary when using the shaft fully extended or fully retracted for the whole life cycle.

*Values truncated

Travel Selection

Linear Travel/ Step	0.0158*	0.0317*	0.0635	0.0953	0.127
Screw Ø5.54 mm					
Part No (X)	B	C	Y	AG	Z

Configuration

Further resolutions available on request.

Custom leadscrew lengths are available on request.



43000 Series

Size 17 Double Stack Linear Actuator External Linear

All dimensions in mm

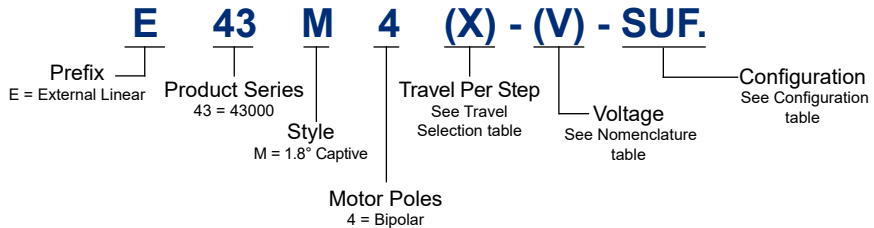
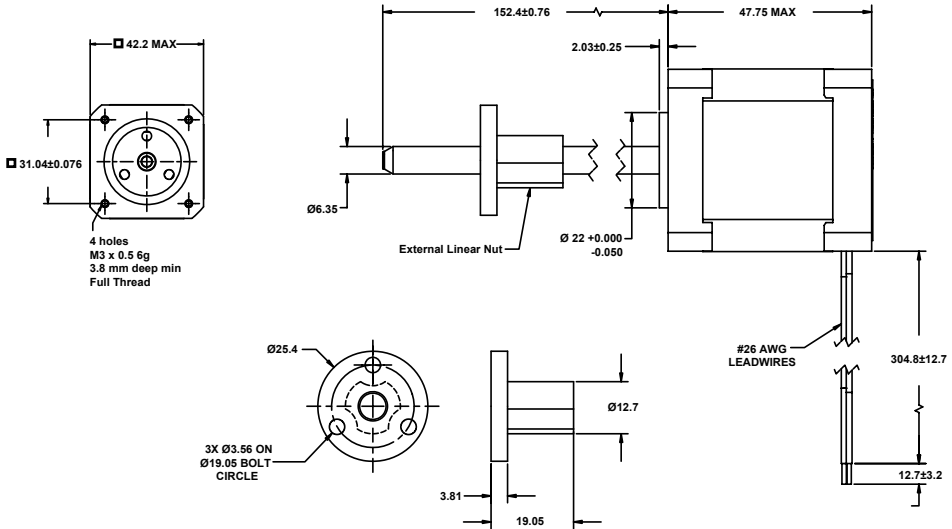

Technical Support

- Selection Guide : Page 1-01
- Product Overview : Page 1-26
- Performance curves : Page 1-108

Actuators



Nomenclature

Size 17 Double Stack: 43 mm Hybrid Linear Actuator (1.8° Step Angle)				
Part No.	External Linear (EM)	E43M4(X)-(V)-SUF.		
Wiring		BIPOLAR (4)		
Winding Voltage (V)	2.33 VDC	5 VDC	12 VDC	
Current (RMS) each phase	1.5 A	1.3 A	550 mA	
Resistance each phase	0.9Ω	3.8Ω	21.9Ω	
Inductance each phase	1.33mH	8.21mH	45.1mH	

Motor Specification

Size 17 Double Stack: 43 mm Hybrid Linear Actuator (1.8° Step Angle)	
Power consumption	10.4 W Total
Rotor Inertia	78.0 gcm ²
Insulation Class	Class B (Class F available)
Weight	352g
Insulation Resistance	20MΩ

Standard motors are Class B rated for maximum temperature of 130°C.

Rating modifiers may be necessary when using the shaft fully extended or fully retracted for the whole life cycle.

*Values truncated

Travel Selection

Linear Travel/ Step	0.0158*	0.0317*	0.0635	0.0953	0.127
Screw Ø5.54 mm					
Part No (X)	B	C	Y	AG	Z

Configuration

Further resolutions available on request.

Custom leadscrew lengths are available on request.



Force vs. Pulse Rate Bipolar. Chopper. 100% Duty Cycle
Ø 6.35 mm Lead-screw

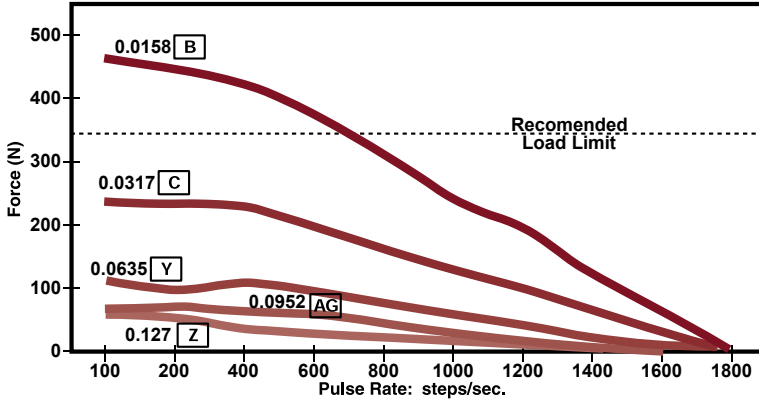

Force vs. Linear Velocity Bipolar. Chopper. 100% Duty Cycle
Ø 6.35 mm Lead-screw

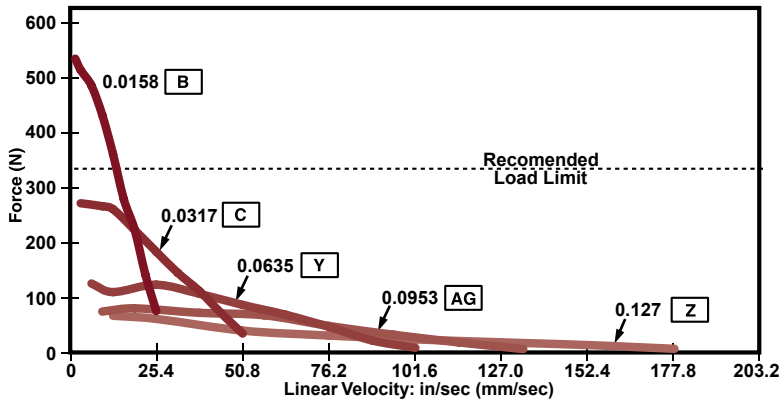

*Care should be taken that the physical load limits of the motor are not exceeded.

Please call for advice when selecting the most appropriate pitch for your application.

NOTE: All Chopper drive curves were generated using a 5 volt motor with a 40 watt power supply. Ramping can increase the performance of a motor either by increasing the top speed or accelerating a heavier load faster. Progressive deceleration can be used to stop the motor without overshoot.

With L/R drives peak force and speeds are reduced, using a unipolar drive will yield a further 30% force reduction.

Actuators

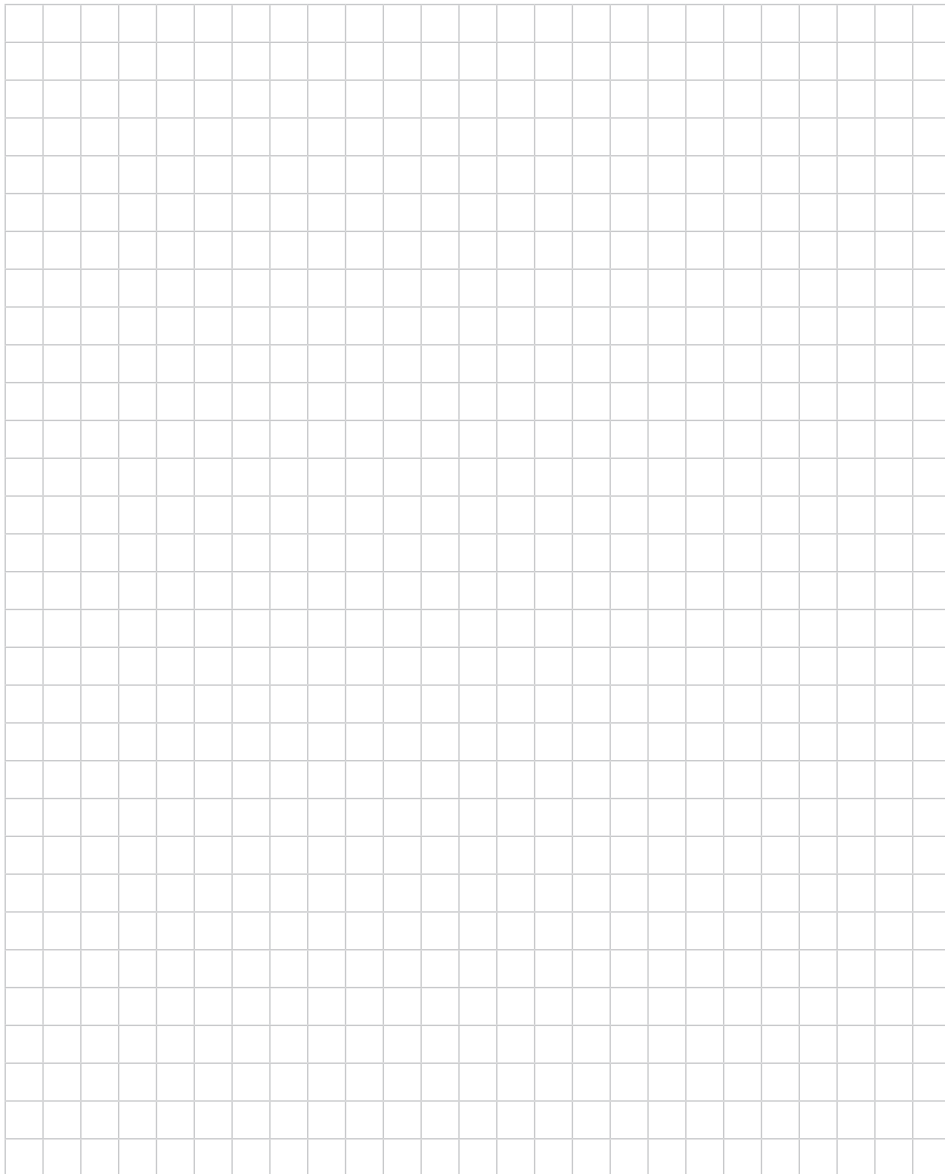



All dimensions in mm

Actuators

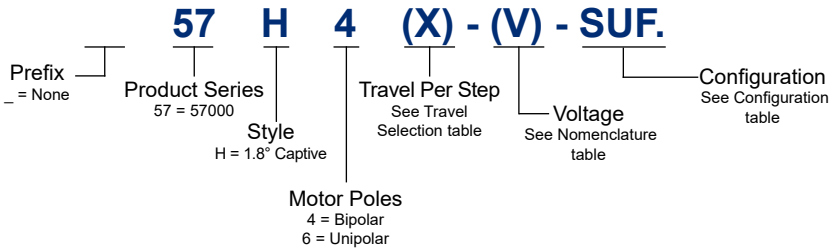
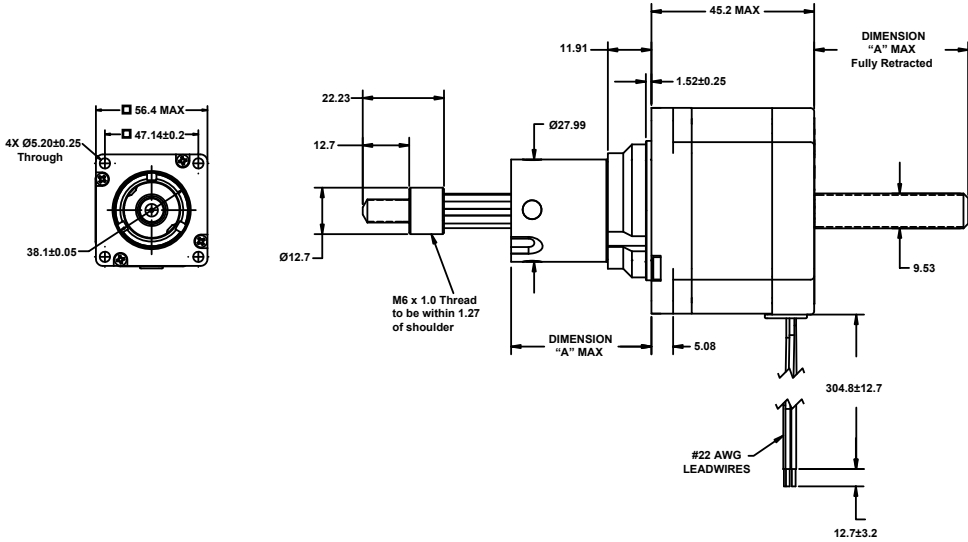

Technical Support

- Selection Guide : Page 1-01
- Product Overview : Page 1-26
- Performance curves : Page 1-116



Nomenclature

Size 23: 57 mm Hybrid Linear Actuator (1.8° Step Angle)						
Part No.	Captive (H)	57H4(X)-(V)-SUF.			57H6(X)-(V)-SUF	
Wiring		BIPOLAR (4)			UNIPOLAR (6)	
Winding Voltage (V)		3.25 VDC	5 VDC	12 VDC	5 VDC	12 VDC
Current (RMS) each phase		2.0 A	1.3 A	0.54 A	1.3 A	0.54 A
Resistance each phase		1.63Ω	3.85Ω	22.2Ω	3.85Ω	22.2Ω
Inductance each phase		3.5mH	10.5mH	58mH	5.3mH	23.6mH

Motor Specification

Size 23: 57 mm Hybrid Linear Actuator (1.8° Step Angle)	
Power consumption	13 W Total
Rotor Inertia	166 gcm ²
Insulation Class	Class B (Class F available)
Weight	511g
Insulation Resistance	20MΩ

Standard motors are Class B rated for maximum temperature of 130°C.

Rating modifiers may be necessary when using the shaft fully extended or fully retracted for the whole life cycle.

**Unipolar drive gives approx 30% less thrust than Bipolar.

*Values truncated

Travel Selection

Linear Travel/ Step	0.0079*	0.0105*	0.0127	0.0211*	0.0254	0.0508
Screw Ø9.53 mm						
Part No (X)	A	S	3	T	1	2

Configuration

Stroke	Dim. "A"	Dim. "B"	SUF.	M6x1.0 Thread
12.7	25.7	1.5	-905	-805
19.05	32.0	7.9	-907	-807
25.4	38.4	14.2	-910	-810
31.75	44.7	20.6	-912	-812
38.1	51.1	26.9	-915	-815
50.8	63.8	39.6	-920	-820
63.5	76.5	52.3	-925	-825

Further resolutions available on request.

Custom leadscrew lengths are available on request.



All dimensions in mm

Actuators

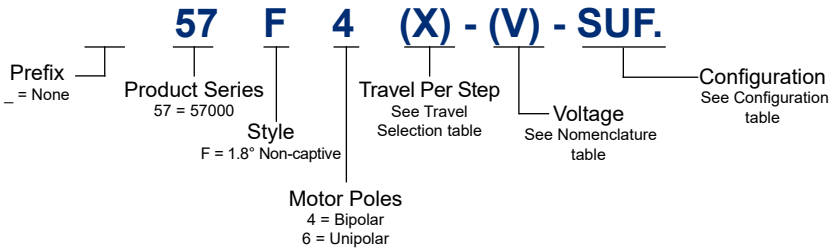
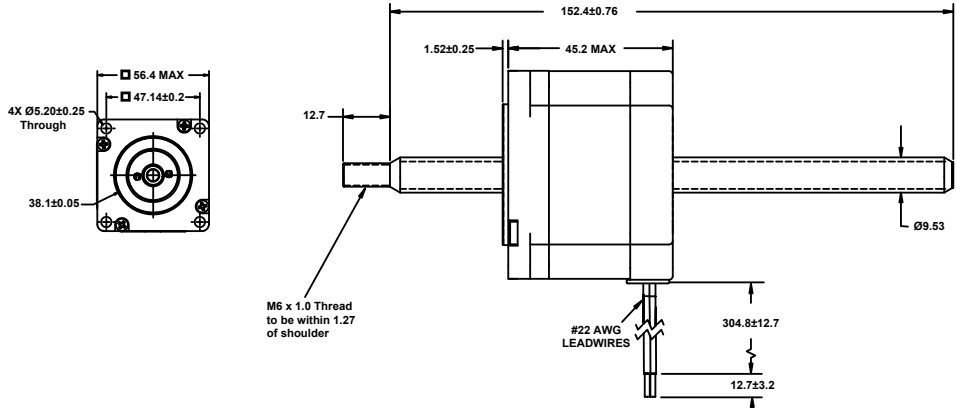

Technical Support

- Selection Guide : Page 1-01
- Product Overview : Page 1-26
- Performance curves : Page 1-116



Nomenclature

Size 23: 57 mm Hybrid Linear Actuator (1.8° Step Angle)						
Part No.	Non-captive (F)	57F4(X)-(V)-SUF.			57F6(X)-(V)-SUF	
Wiring		BIPOLAR (4)			UNIPOLAR (6)	
Winding Voltage (V)		3.25 VDC	5 VDC	12 VDC	5 VDC	12 VDC
Current (RMS) each phase		2.0 A	1.3 A	0.54 A	1.3 A	0.54 A
Resistance each phase		1.63Ω	3.85Ω	22.2Ω	3.85Ω	22.2Ω
Inductance each phase		3.5mH	10.5mH	58mH	5.3mH	23.6mH

Motor Specification

Size 23: 57 mm Hybrid Linear Actuator (1.8° Step Angle)	
Power consumption	13 W Total
Rotor Inertia	166 gcm ²
Insulation Class	Class B (Class F available)
Weight	511g
Insulation Resistance	20MΩ

Standard motors are Class B rated for maximum temperature of 130°C.

Rating modifiers may be necessary when using the shaft fully extended or fully retracted for the whole life cycle.

**Unipolar drive gives approx 30% less thrust than Bipolar.

*Values truncated

Travel Selection

Linear Travel/ Step	0.0079*	0.0105*	0.0127	0.0211*	0.0254	0.0508
Screw Ø9.53 mm						
Part No (X)	A	S	3	T	1	2

Configuration

Further resolutions available on request.

Custom leadscrew lengths are available on request.



All dimensions in mm

Actuators

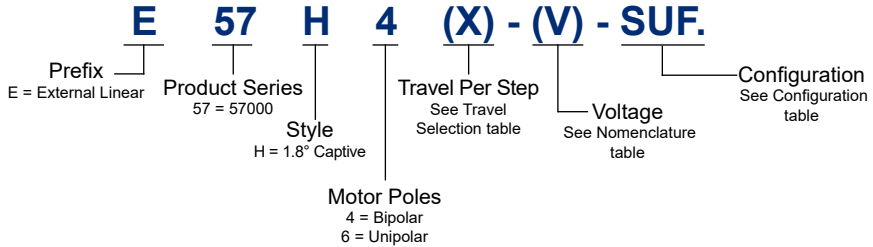
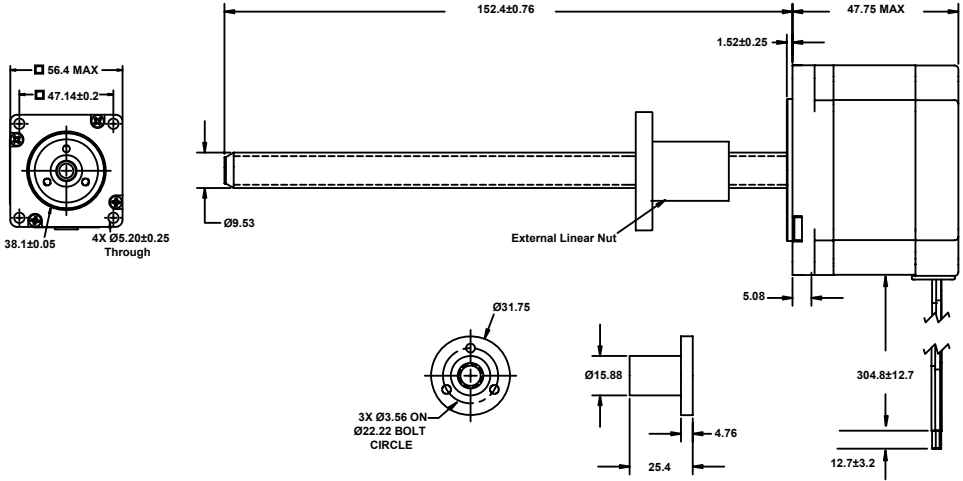

Technical Support

- Selection Guide : Page 1-01
- Product Overview : Page 1-26
- Performance curves : Page 1-116



Nomenclature

Size 23: 57 mm Hybrid Linear Actuator (1.8° Step Angle)						
Part No.	External Linear (EH)	E57H4(X)-(V)-SUF.			E57H6(X)-(V)-SUF	
Wiring		BIPOLAR (4)			UNIPOLAR (6)	
Winding Voltage (V)		3.25 VDC	5 VDC	12 VDC	5 VDC	12 VDC
Current (RMS) each phase		2.0 A	1.3 A	0.54 A	1.3 A	0.54 A
Resistance each phase		1.63Ω	3.85Ω	22.2Ω	3.85Ω	22.2Ω
Inductance each phase		3.5mH	10.5mH	58mH	5.3mH	23.6mH

Motor Specification

Size 23: 57 mm Hybrid Linear Actuator (1.8° Step Angle)	
Power consumption	13 W Total
Rotor Inertia	166 gcm ²
Insulation Class	Class B (Class F available)
Weight	511g
Insulation Resistance	20MΩ

Standard motors are Class B rated for maximum temperature of 130°C.

Rating modifiers may be necessary when using the shaft fully extended or fully retracted for the whole life cycle.

**Unipolar drive gives approx 30% less thrust than Bipolar.

*Values truncated

Travel Selection

Linear Travel/ Step	0.0079*	0.0105*	0.0127	0.0211*	0.0254	0.0508
Screw Ø9.53 mm						
Part No (X)	A	S	3	T	1	2

Configuration

Further resolutions available on request.

Custom leadscrew lengths are available on request.



Force vs. Pulse Rate Bipolar. Chopper. 100% Duty Cycle
Ø 9.53 mm Lead-screw

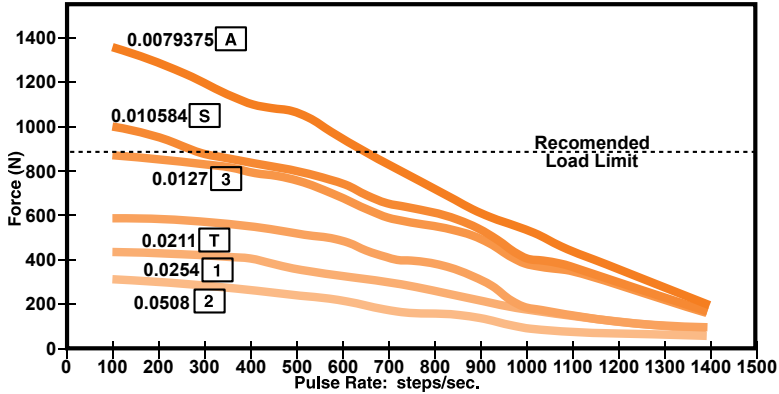

Force vs. Linear Velocity Bipolar. Chopper. 100% Duty Cycle
Ø 9.53 mm Lead-screw

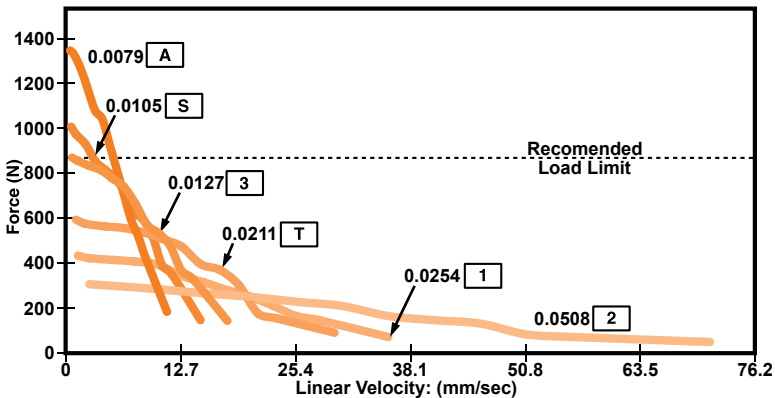

*Care should be taken that the physical load limits of the motor are not exceeded.

Please call for advice when selecting the most appropriate pitch for your application.

NOTE: All Chopper drive curves were generated using a 5 volt motor with a 40 watt power supply. Ramping can increase the performance of a motor either by increasing the top speed or accelerating a heavier load faster. Progressive deceleration can be used to stop the motor without overshoot.

With L/R drives peak force and speeds are reduced, using a unipolar drive will yield a further 30% force reduction.



All dimensions in mm

Actuators

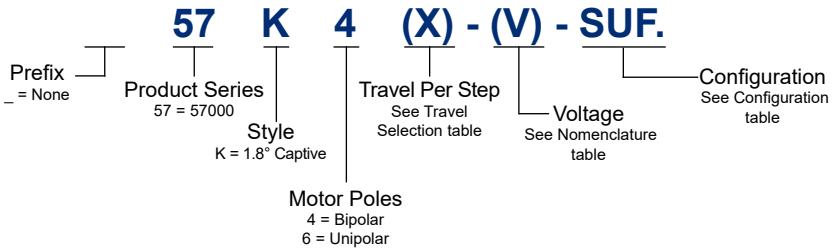
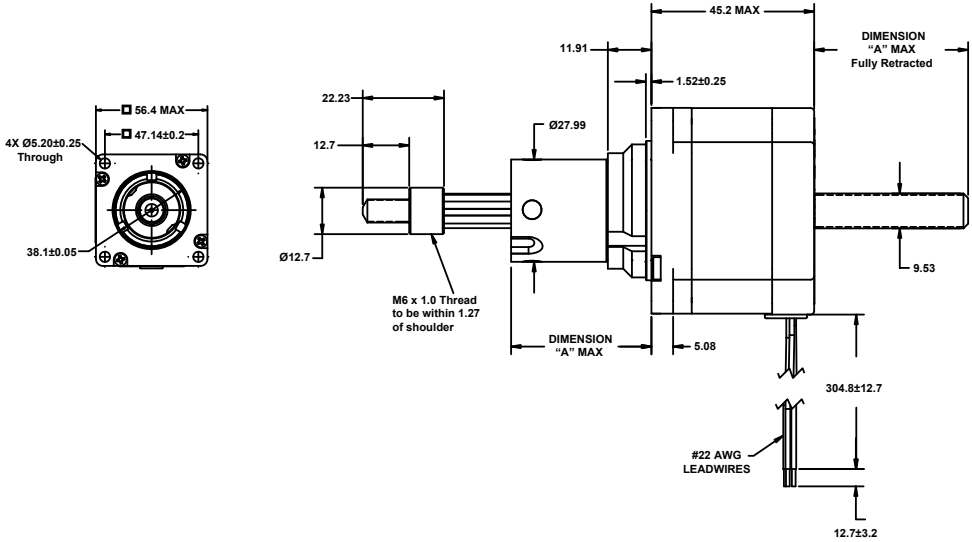

Technical Support

- Selection Guide : [Page 1-01](#)
- Product Overview : [Page 1-26](#)
- Performance curves : [Page 1-124](#)



Nomenclature

Size 23 High Res: 57 mm Hybrid Linear Actuator (0.9° Step Angle)						
Part No.	Captive (K)	57K4(X)-(V)-SUF.			57K6(X)-(V)-SUF	
Wiring		BIPOLAR (4)			UNIPOLAR (6)	
Winding Voltage (V)		3.25 VDC	5 VDC	12 VDC	5 VDC	12 VDC
Current (RMS) each phase		2.0 A	1.3 A	0.54 A	1.3 A	0.54 A
Resistance each phase		1.63Ω	3.85Ω	22.2Ω	3.85Ω	22.2Ω
Inductance each phase		4.2mH	13mH	68mH	6mH	27mH

Motor Specification

Size 23 High Res: 57 mm Hybrid Linear Actuator (0.9° Step Angle)	
Power consumption	13 W Total
Rotor Inertia	166 gcm ²
Insulation Class	Class B (Class F available)
Weight	511g
Insulation Resistance	20MΩ

Standard motors are Class B rated for maximum temperature of 130°C.

Rating modifiers may be necessary when using the shaft fully extended or fully retracted for the whole life cycle.

**Unipolar drive gives approx 30% less thrust than Bipolar.

*Values truncated

Travel Selection

Linear Travel/ Step	0.0031*	0.0040*	0.0053*	0.0063*	0.0106*	0.0127	0.0254
Screw Ø9.53 mm							
Part No (X)	7	P	X	9	S	3	1

Configuration

Stroke	Dim. "A"	Dim. "B"	SUF.	M6x1.0 Thread
12.7	25.7	1.5	-905	-805
19.05	32.0	7.9	-907	-807
25.4	38.4	14.2	-910	-810
31.75	44.7	20.6	-912	-812
38.1	51.1	26.9	-915	-815
50.8	63.8	39.6	-920	-820
63.5	76.5	52.3	-925	-825

Further resolutions available on request.

Custom leadscrew lengths are available on request.



57000 Series

Size 23 High Resolution Linear Actuator Non-captive Shaft

All dimensions in mm

Actuators

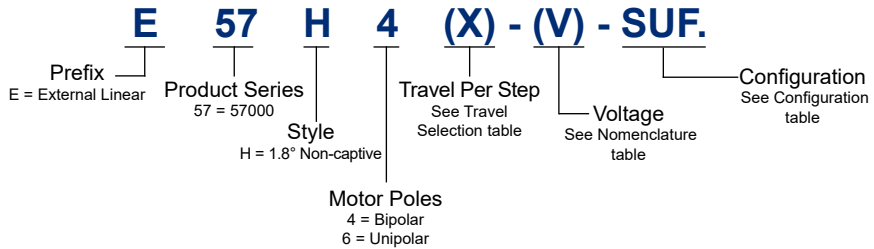
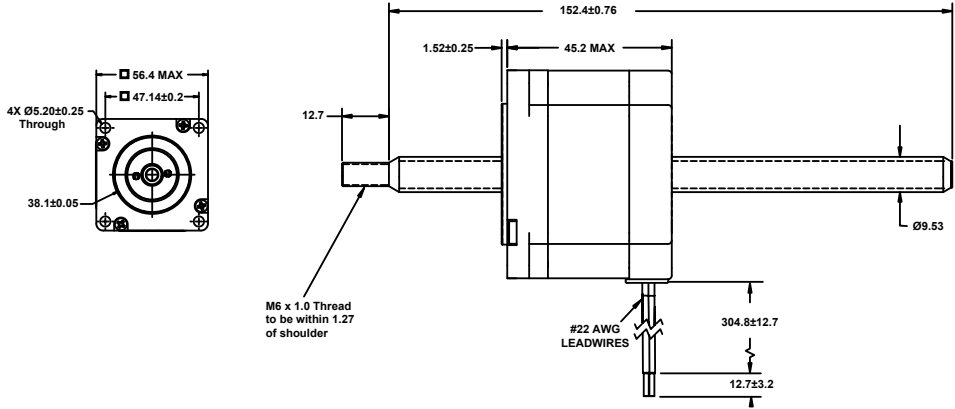

Technical Support

- Selection Guide : Page 1-01
- Product Overview : Page 1-26
- Performance curves : Page 1-124

Size 23 High Resolution Linear Actuator Non-captive Shaft

57000 Series



Actuators

Nomenclature

Size 23 High Res: 57 mm Hybrid Linear Actuator (0.9° Step Angle)						
Part No.	Non-captive (J)	57J4(X)-(V)-SUF.			57J6(X)-(V)-SUF	
Wiring		BIPOLAR (4)			UNIPOLAR (6)	
Winding Voltage (V)		3.25 VDC	5 VDC	12 VDC	5 VDC	12 VDC
Current (RMS) each phase		2.0 A	1.3 A	0.54 A	1.3 A	0.54 A
Resistance each phase		1.63Ω	3.85Ω	22.2Ω	3.85Ω	22.2Ω
Inductance each phase		4.2mH	13mH	68mH	6mH	27mH

Motor Specification

Size 23 High Res: 57 mm Hybrid Linear Actuator (0.9° Step Angle)	
Power consumption	13 W Total
Rotor Inertia	166 gcm ²
Insulation Class	Class B (Class F available)
Weight	511g
Insulation Resistance	20MΩ

Standard motors are Class B rated for maximum temperature of 130°C.

Rating modifiers may be necessary when using the shaft fully extended or fully retracted for the whole life cycle.

**Unipolar drive gives approx 30% less thrust than Bipolar.

*Values truncated

Travel Selection

Linear Travel/ Step	0.0031*	0.0040*	0.0053*	0.0063*	0.0106*	0.0127	0.0254
Screw Ø9.53 mm							
Part No (X)	7	P	X	9	S	3	1

Configuration

Further resolutions available on request.

Custom leadscrew lengths are available on request.



All dimensions in mm

Actuators

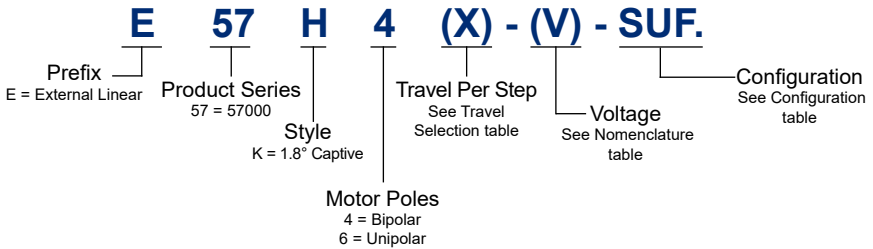
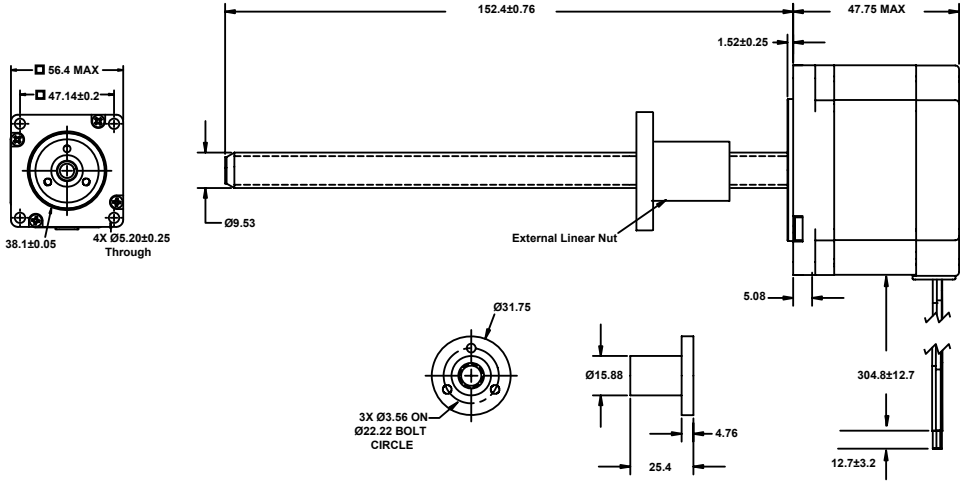

Technical Support

- Selection Guide : Page 1-01
- Product Overview : Page 1-26
- Performance curves : Page 1-124



Nomenclature

Size 23 High Res: 57 mm Hybrid Linear Actuator (0.9° Step Angle)						
Part No.	External Linear (EK)	E57K4(X)-(V)-SUF.			57K6(X)-(V)-SUF	
Wiring		BIPOLAR (4)			UNIPOLAR (6)	
Winding Voltage (V)		3.25 VDC	5 VDC	12 VDC	5 VDC	12 VDC
Current (RMS) each phase		2.0 A	1.3 A	0.54 A	1.3 A	0.54 A
Resistance each phase		1.63Ω	3.85Ω	22.2Ω	3.85Ω	22.2Ω
Inductance each phase		4.2mH	13mH	68mH	6mH	27mH

Motor Specification

Size 23 High Res: 57 mm Hybrid Linear Actuator (0.9° Step Angle)	
Power consumption	13 W Total
Rotor Inertia	166 gcm ²
Insulation Class	Class B (Class F available)
Weight	511g
Insulation Resistance	20MΩ

Standard motors are Class B rated for maximum temperature of 130°C.

Rating modifiers may be necessary when using the shaft fully extended or fully retracted for the whole life cycle.

**Unipolar drive gives approx 30% less thrust than Bipolar.

*Values truncated

Travel Selection

Linear Travel/ Step	0.0031*	0.0040*	0.0053*	0.0063*	0.0106*	0.0127	0.0254
Screw Ø9.53 mm							
Part No (X)	7	P	X	9	S	3	1

Configuration

Further resolutions available on request.

Custom leadscrew lengths are available on request.



Actuators

Force vs. Pulse Rate Bipolar. Chopper. 100% Duty Cycle
Ø 9.53 mm Lead-screw

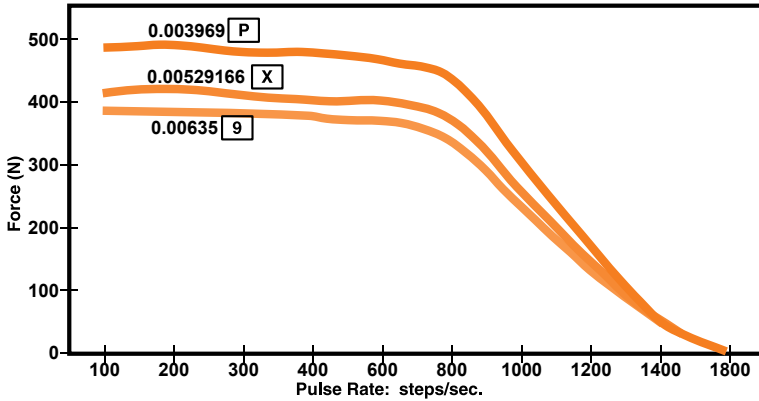

Force vs. Linear Velocity Bipolar. Chopper. 100% Duty Cycle
Ø 9.53 mm Lead-screw

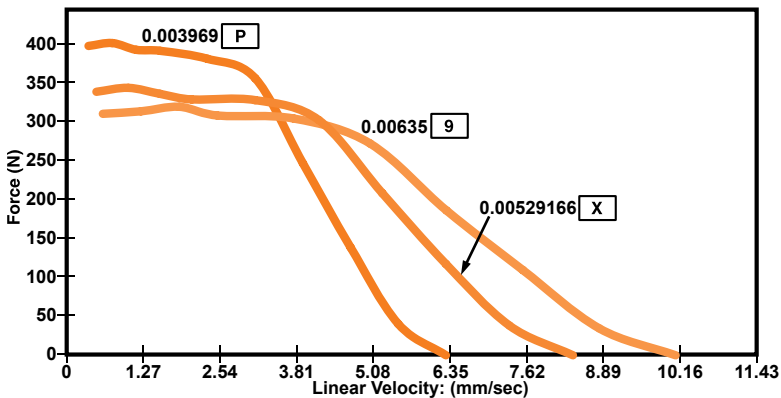

*Care should be taken that the physical load limits of the motor are not exceeded.

Please call for advice when selecting the most appropriate pitch for your application.

NOTE: All Chopper drive curves were generated using a 5 volt motor with a 40 watt power supply. Ramping can increase the performance of a motor either by increasing the top speed or accelerating a heavier load faster. Progressive deceleration can be used to stop the motor without overshoot.

With L/R drives peak force and speeds are reduced, using a unipolar drive will yield a further 30% force reduction.



All dimensions in mm

Actuators

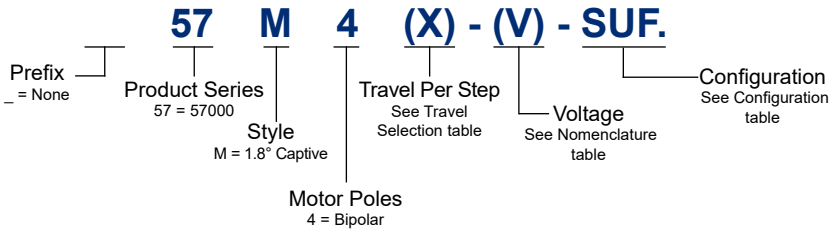
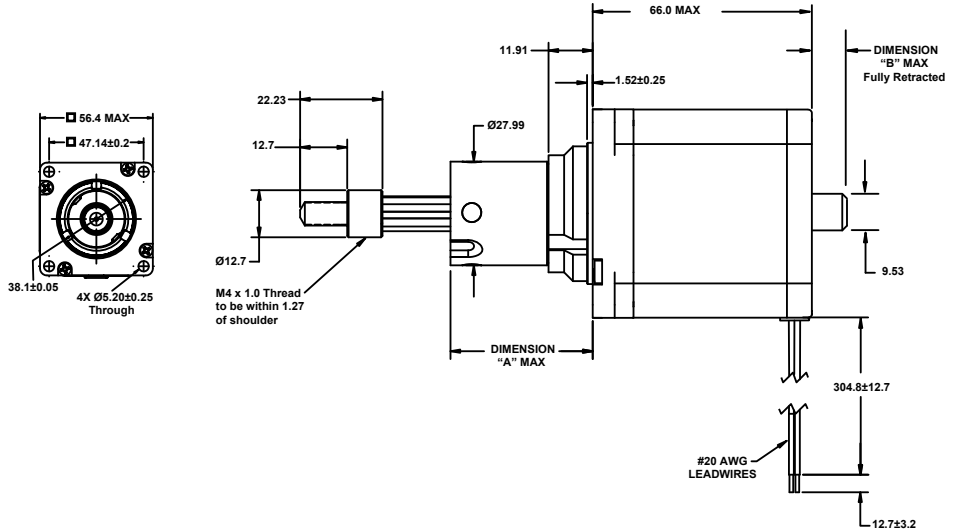

Technical Support

- Selection Guide : Page 1-01
- Product Overview : Page 1-26
- Performance curves : Page 1-132



Nomenclature

Size 23 Double Stack: 57 mm Hybrid Linear Actuator (1.8° Step Angle)				
Part No.	Captive (M)	57M4(X)-(V)-SUF.		
Wiring		BIPOLAR (4)		
Winding Voltage (V)		3.25 VDC	5 VDC	12 VDC
Current (RMS) each phase		3.85 A	2.5 A	1 A
Resistance each phase		0.8Ω	2.0Ω	12.92Ω
Inductance each phase		2.3mH	7.6mH	35.0mH

Motor Specification

Size 23 Double Stack: 57 mm Hybrid Linear Actuator (1.8° Step Angle)	
Power consumption	253 W Total
Rotor Inertia	332 gcm ²
Insulation Class	Class B (Class F available)
Weight	958g
Insulation Resistance	20MΩ

Standard motors are Class B rated for maximum temperature of 130°C.

Rating modifiers may be necessary when using the shaft fully extended or fully retracted for the whole life cycle.

*Values truncated

Travel Selection

Linear Travel/ Step	0.0127	0.0254	0.0508	0.0635	0.127
Screw Ø9.53 mm					
Part No (X)	3	1	2	Y	Z

Configuration

Stroke	Dim. "A"	Dim. "B"	SUF.	M6x1.0 Thread
12.7	25.7	0	-905	-805
19.05	32.0	2.77	-907	-807
25.4	38.4	7.37	-910	-810
31.75	44.7	15.47	-912	-812
38.1	51.1	21.83	-915	-815
50.8	63.8	34.52	-920	-820
63.5	76.5	47.22	-925	-825

Further resolutions available on request.

Custom leadscrew lengths are available on request.



57000 Series

Size 23 Double Stack Linear Actuator Non-captive Shaft

All dimensions in mm

Actuators

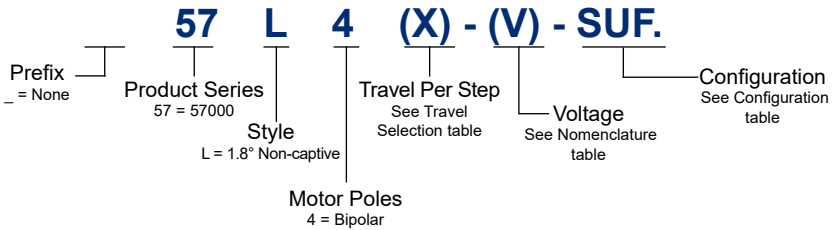
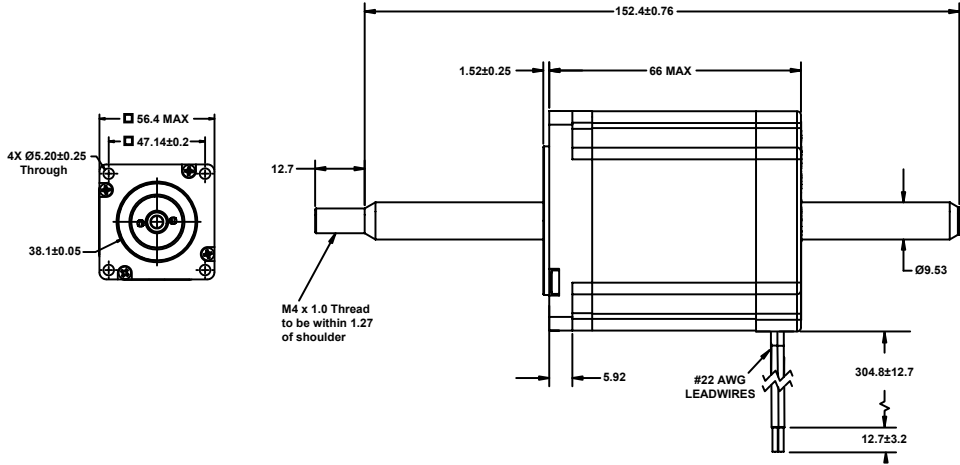

Technical Support

- Selection Guide : Page 1-01
- Product Overview : Page 1-26
- Performance curves : Page 1-132

Size 23 Double Stack Linear Actuator Non-captive Shaft

57000 Series



Actuators

Nomenclature

Size 23 Double Stack: 57 mm Hybrid Linear Actuator (1.8° Step Angle)				
Part No.	Non-captive (L)	57L4(X)-(V)-SUF.		
Wiring		BIPOLAR (4)		
Winding Voltage (V)		3.25 VDC	5 VDC	12 VDC
Current (RMS) each phase		3.85 A	2.5 A	1 A
Resistance each phase		0.8Ω	2.0Ω	12.92Ω
Inductance each phase		2.3mH	7.6mH	35.0mH

Motor Specification

Size 23 Double Stack: 57 mm Hybrid Linear Actuator (1.8° Step Angle)	
Power consumption	253 W Total
Rotor Inertia	332 gcm ²
Insulation Class	Class B (Class F available)
Weight	958g
Insulation Resistance	20MΩ

Standard motors are Class B rated for maximum temperature of 130°C.

Rating modifiers may be necessary when using the shaft fully extended or fully retracted for the whole life cycle.

*Values truncated

Travel Selection

Linear Travel/ Step	0.0127	0.0254	0.0508	0.0635	0.127
Screw Ø9.53 mm					
Part No (X)	3	1	2	Y	Z

Configuration

Further resolutions available on request.

Custom leadscrew lengths are available on request.



All dimensions in mm

Actuators

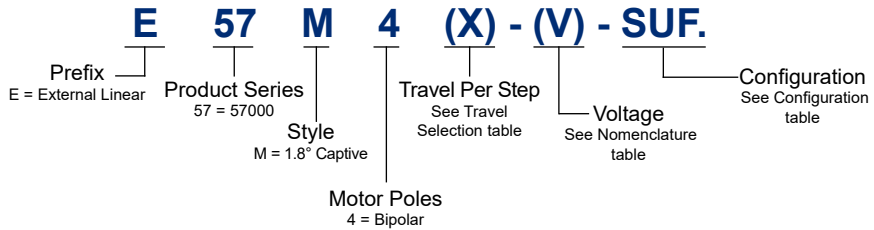
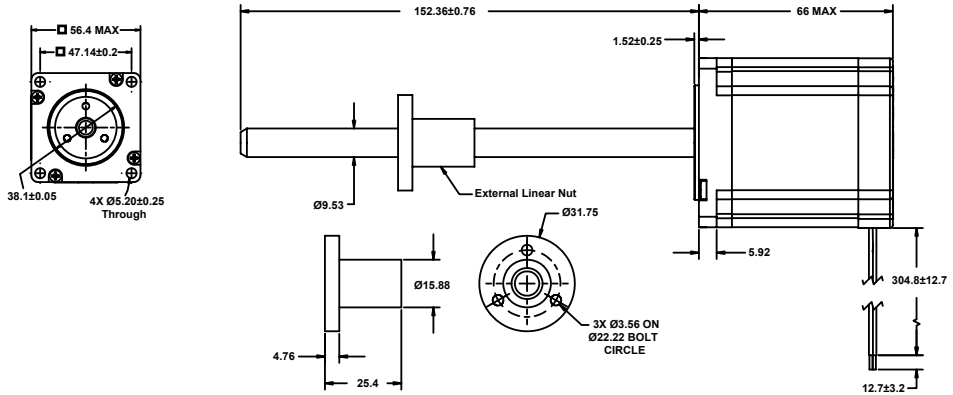

Technical Support

- Selection Guide : Page 1-01
- Product Overview : Page 1-26
- Performance curves : Page 1-132



Nomenclature

Size 23 Double Stack: 57 mm Hybrid Linear Actuator (1.8° Step Angle)				
Part No.	External Linear (EM)	E57M4(X)-(V)-SUF.		
Wiring		BIPOLAR (4)		
Winding Voltage (V)		3.25 VDC	5 VDC	12 VDC
Current (RMS) each phase		3.85 A	2.5 A	1 A
Resistance each phase		0.8Ω	2.0Ω	12.92Ω
Inductance each phase		2.3mH	7.6mH	35.0mH

Motor Specification

Size 23 Double Stack: 57 mm Hybrid Linear Actuator (1.8° Step Angle)	
Power consumption	253 W Total
Rotor Inertia	332 gcm ²
Insulation Class	Class B (Class F available)
Weight	958g
Insulation Resistance	20MΩ

Standard motors are Class B rated for maximum temperature of 130°C.

Rating modifiers may be necessary when using the shaft fully extended or fully retracted for the whole life cycle.

*Values truncated

Travel Selection

Linear Travel/ Step	0.0127	0.0254	0.0508	0.0635	0.127
Screw Ø9.53 mm					
Part No (X)	3	1	2	Y	Z

Configuration

Further resolutions available on request.

Custom leadscrew lengths are available on request.



Actuators

Force vs. Pulse Rate Bipolar. Chopper. 100% Duty Cycle
Ø 9.53 mm Lead-screw

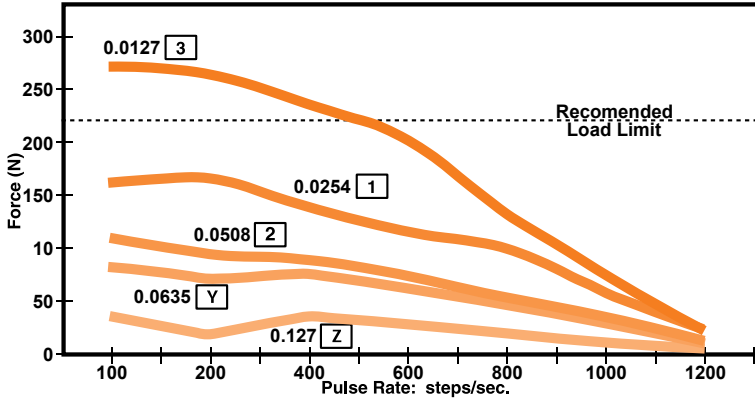

Force vs. Linear Velocity Bipolar. Chopper. 100% Duty Cycle
Ø 9.53 mm Lead-screw

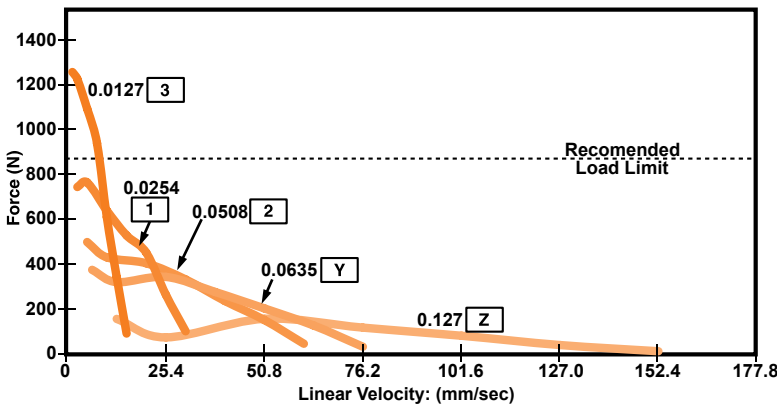

*Care should be taken that the physical load limits of the motor are not exceeded.

Please call for advice when selecting the most appropriate pitch for your application.

NOTE: All Chopper drive curves were generated using a 5 volt motor with a 40 watt power supply. Ramping can increase the performance of a motor either by increasing the top speed or accelerating a heavier load faster. Progressive deceleration can be used to stop the motor without overshoot.

With L/R drives peak force and speeds are reduced, using a unipolar drive will yield a further 30% force reduction.



All dimensions in mm

Actuators

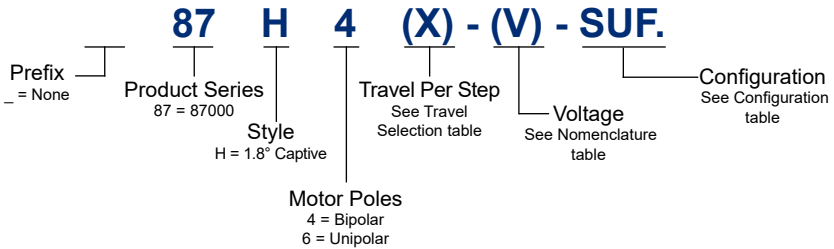
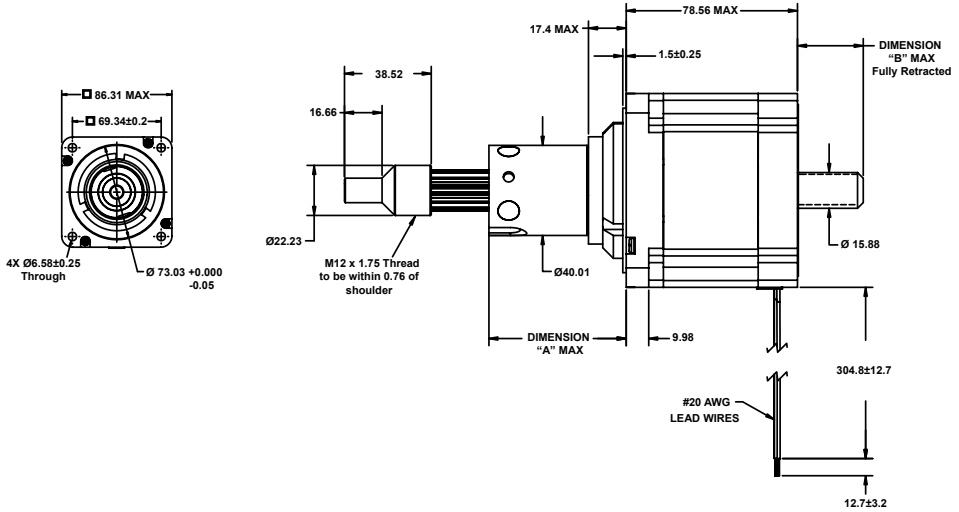

Technical Support

- Selection Guide : Page 1-01
- Product Overview : Page 1-26
- Performance curves : Page 1-140



Nomenclature

Size 34: 87 mm Hybrid Linear Actuator (1.8° Step Angle)						
Part No.	Captive (H)	87H4(X)-(V)-SUF.			87H6(X)-(V)-SUF.	
Wiring		BIPOLAR (4)			UNIPOLAR (6)	
Winding Voltage (V)		2.85 VDC	5 VDC	12 VDC	5 VDC	12VDC
Current (RMS) each phase		5.47 A	3.12 A	1.3 A	3.12 A	1.3 A
Resistance each phase		0.52Ω	1.6Ω	9.23Ω	1.6Ω	9.23Ω
Inductance each phase		2.86mH	8.8mH	51mH	4.4mH	25.5mH

Motor Specification

Size 34: 87 mm Hybrid Linear Actuator (1.8° Step Angle)	
Power consumption	31.2 W Total
Rotor Inertia	1760 gcm ²
Insulation Class	Class B (Class F available)
Weight	2.3Kg
Insulation Resistance	20MΩ

Standard motors are Class B rated for maximum temperature of 130°C.

Rating modifiers may be necessary when using the shaft fully extended or fully retracted for the whole life cycle.

**Unipolar drive gives approx 30% less thrust than Bipolar.

*Values truncated

Travel Selection

Linear Travel/ Step	0.0127	0.0158*	0.0317*	0.0635	0.127
Screw Ø15.88 mm					
Part No (X)	3	B	C	Y	Z

Configuration

Stroke	Dim. "A"	Dim. "B"	SUF.	M12x1.75 Thread
12.7	31.12	0	-905	-805
25.4	43.82	6.35	-910	-810
38.1	56.52	19.05	-915	-815
50.8	69.22	31.75	-920	-820
63.5	81.92	44.45	-925	-825

Further resolutions available on request.

Custom leadscrew lengths are available on request.



All dimensions in mm

Actuators

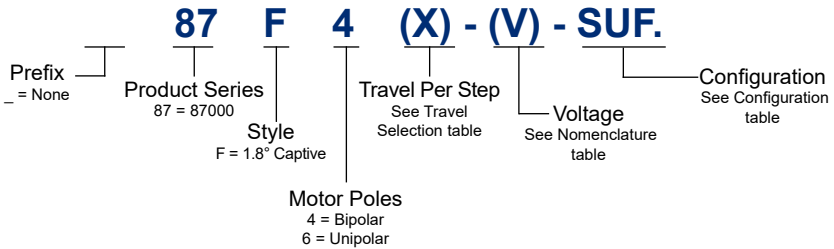
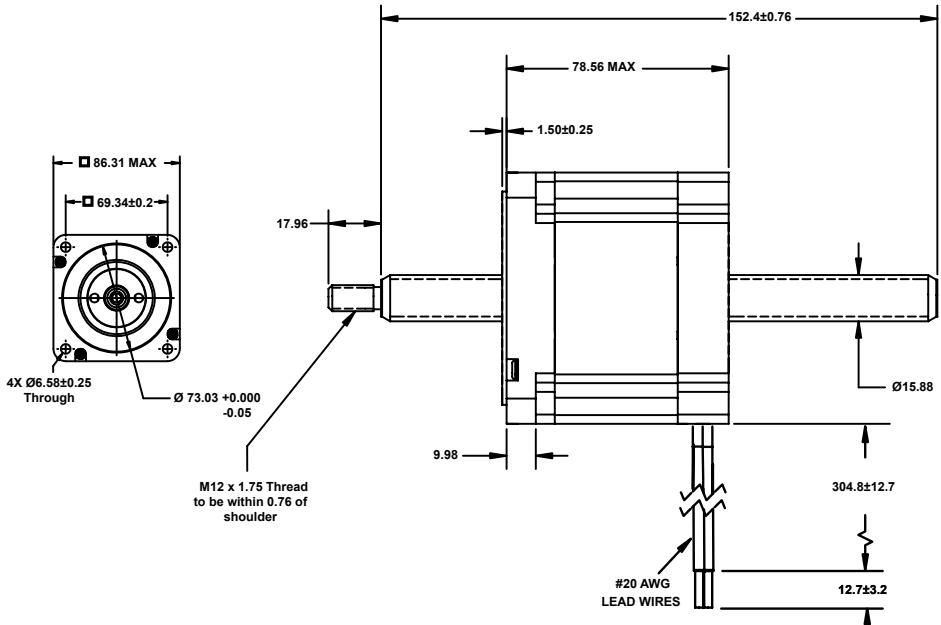

Technical Support

- Selection Guide : Page 1-01
- Product Overview : Page 1-26
- Performance curves : Page 1-140



Nomenclature

Size 34: 87 mm Hybrid Linear Actuator (1.8° Step Angle)						
Part No.	Non-captive (F)	87F4(X)-(V)-SUF.			87F6(X)-(V)-SUF.	
Wiring		BIPOLAR (4)			UNIPOLAR (6)	
Winding Voltage (V)		2.85 VDC	5 VDC	12 VDC	5 VDC	12VDC
Current (RMS) each phase		5.47 A	3.12 A	1.3 A	3.12 A	1.3 A
Resistance each phase		0.52Ω	1.6Ω	9.23Ω	1.6Ω	9.23Ω
Inductance each phase		2.86mH	8.8mH	51mH	4.4mH	25.5mH

Motor Specification

Size 34: 87 mm Hybrid Linear Actuator (1.8° Step Angle)	
Power consumption	31.2 W Total
Rotor Inertia	1760 gcm ²
Insulation Class	Class B (Class F available)
Weight	2.3Kg
Insulation Resistance	20MΩ

Standard motors are Class B rated for maximum temperature of 130°C.

Rating modifiers may be necessary when using the shaft fully extended or fully retracted for the whole life cycle.

**Unipolar drive gives approx 30% less thrust than Bipolar.

*Values truncated

Travel Selection

Linear Travel/ Step	0.0127	0.0158*	0.0317*	0.0635	0.127
Screw Ø15.88 mm					
Part No (X)	3	B	C	Y	Z

Configuration

Further resolutions available on request.

Custom leadscrew lengths are available on request.



All dimensions in mm

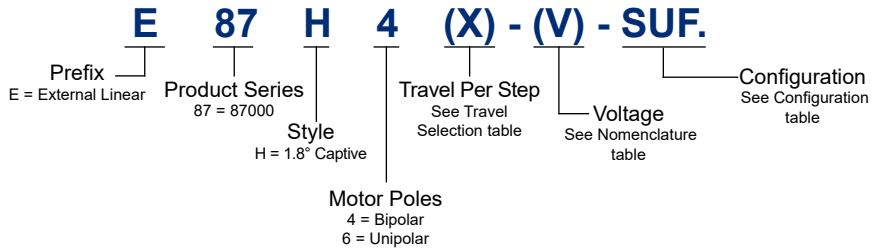
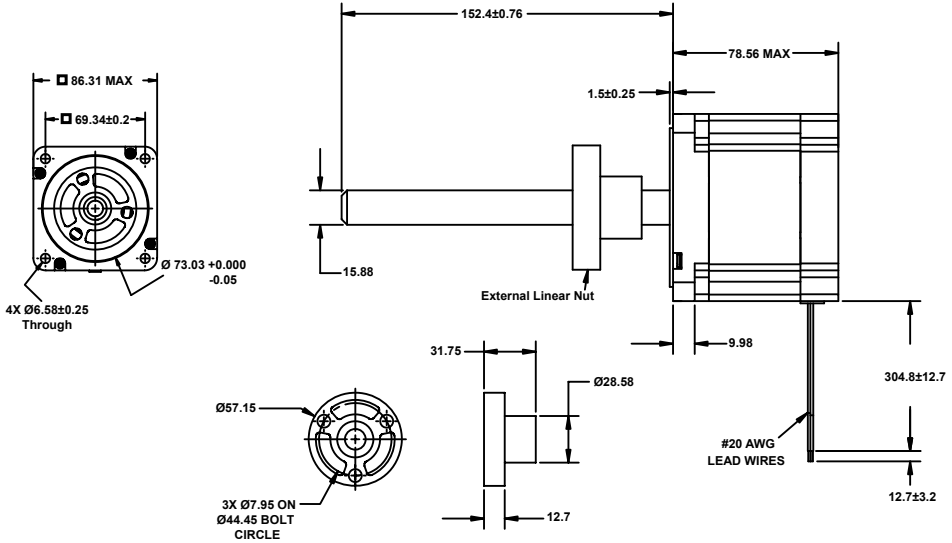

Technical Support

- Selection Guide : Page 1-01
- Product Overview : Page 1-26
- Performance curves : Page 1-140

Actuators



Nomenclature

Size 34: 87 mm Hybrid Linear Actuator (1.8° Step Angle)						
Part No.	External Linear (EH)	E87H4(X)-(V)-SUF.			E87H6(X)-(V)-SUF.	
Wiring		BIPOLAR (4)			UNIPOLAR (6)	
Winding Voltage (V)		2.85 VDC	5 VDC	12 VDC	5 VDC	12VDC
Current (RMS) each phase		5.47 A	3.12 A	1.3 A	3.12 A	1.3 A
Resistance each phase		0.52Ω	1.6Ω	9.23Ω	1.6Ω	9.23Ω
Inductance each phase		2.86mH	8.8mH	51mH	4.4mH	25.5mH

Motor Specification

Size 34: 87 mm Hybrid Linear Actuator (1.8° Step Angle)	
Power consumption	31.2 W Total
Rotor Inertia	1760 gcm ²
Insulation Class	Class B (Class F available)
Weight	2.3Kg
Insulation Resistance	20MΩ

Standard motors are Class B rated for maximum temperature of 130°C.

Rating modifiers may be necessary when using the shaft fully extended or fully retracted for the whole life cycle.

**Unipolar drive gives approx 30% less thrust than Bipolar.

*Values truncated

Travel Selection

Linear Travel/ Step	0.0127	0.0158*	0.0317*	0.0635	0.127
Screw Ø15.88 mm					
Part No (X)	3	B	C	Y	Z

Configuration

Further resolutions available on request.

Custom leadscrew lengths are available on request.



Force vs. Pulse Rate Bipolar. Chopper. 100% Duty Cycle
Ø 15.88 mm Lead-screw

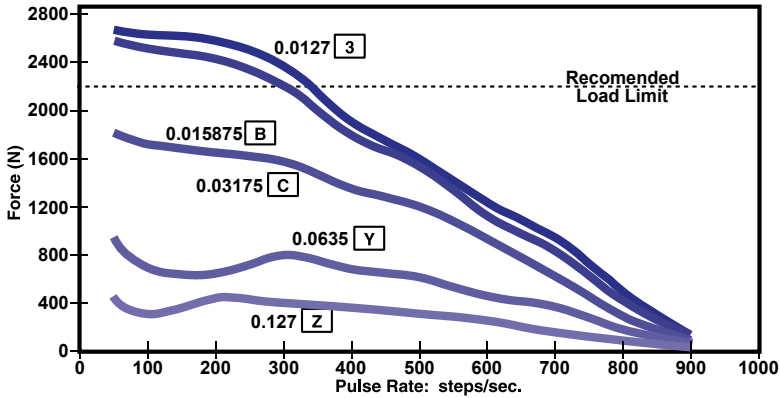

Force vs. Linear Velocity Bipolar. Chopper. 100% Duty Cycle
Ø 15.88 mm Lead-screw

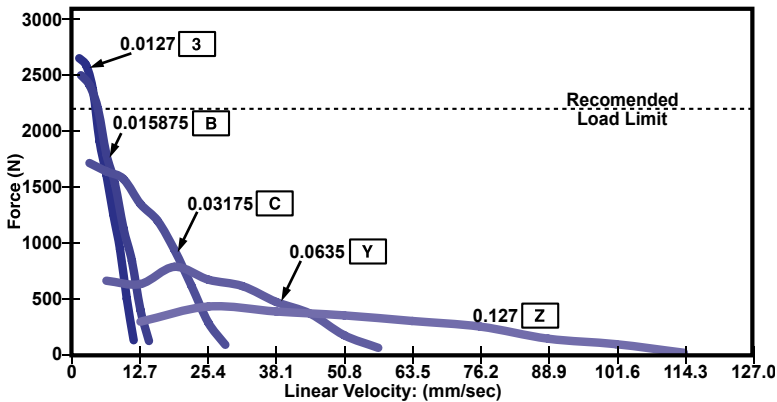

*Care should be taken that the physical load limits of the motor are not exceeded.

Please call for advice when selecting the most appropriate pitch for your application.

NOTE: All Chopper drive curves were generated using a 5 volt motor with a 40 watt power supply. Ramping can increase the performance of a motor either by increasing the top speed or accelerating a heavier load faster. Progressive deceleration can be used to stop the motor without overshoot.

With L/R drives peak force and speeds are reduced, using a unipolar drive will yield a further 30% force reduction.

Actuators

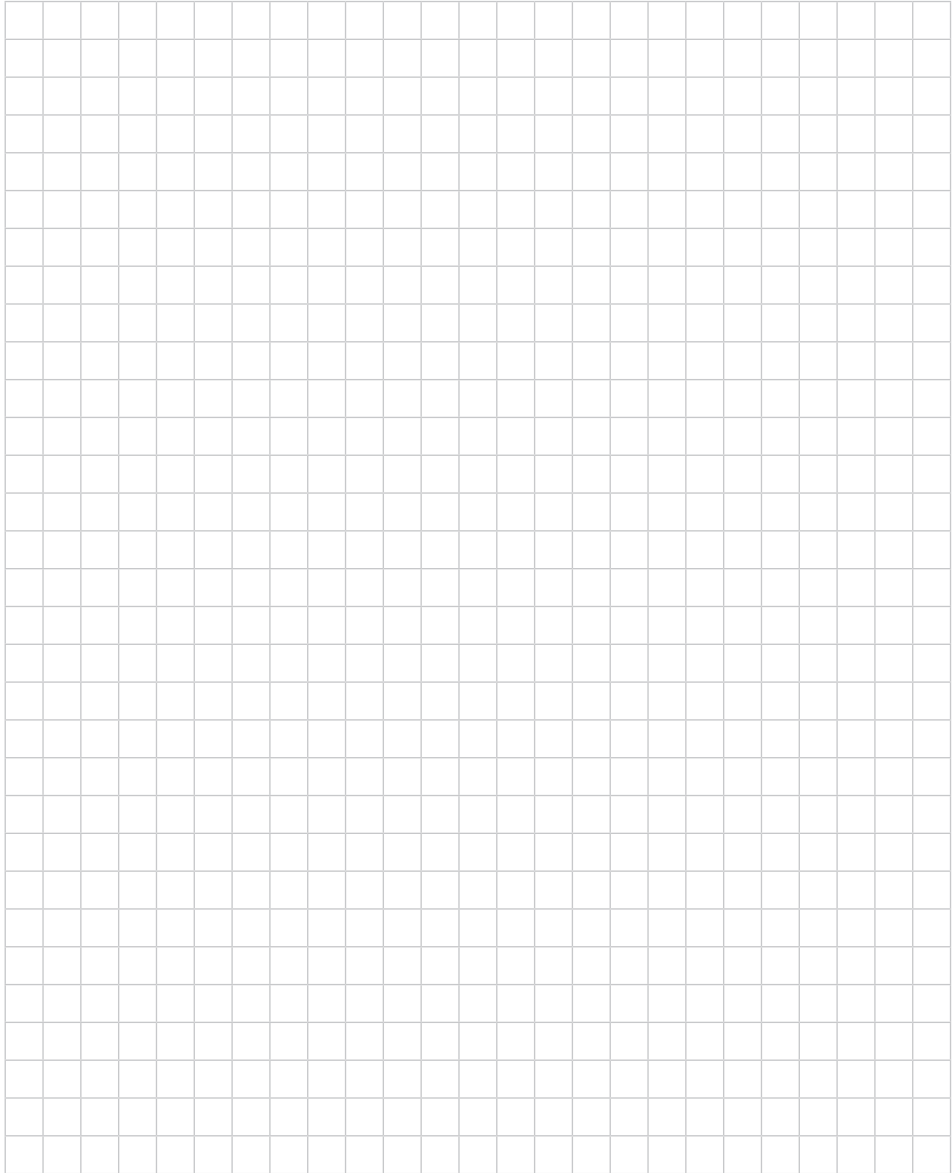



Integrated Connectors for Size 11, Size 14 and Size 17 Hybrid Linear Actuators

Hybrid Size 11, 14 and Size 17 linear actuators are available with an integrated connector. Offered alone or with a harness assembly, this connector is RoHS compliant and features a positive latch for connection integrity. The connector is rated up to 3 amps and will suit a range of wire gauges from 22 to 28. This motor is ideal to plug in directly to pre existing harnesses. Specific design features can be included to suit application requirements. This includes standard and custom nuts for all external linear actuators.

Actuators

Size 14 Linear actuator with integrated connector

Pin#	Bipolar	Unipolar
1	Phase 2 Start	Phase 2 Start
2	Open	Phase 22 Common
3	Phase 2 Finish	Phase 2 Finish
4	Phase 1 Finish	Phase 1 Finish
5	Open	Phase 1 Common
6	Phase 1 Start	Phase 1 Start

Motor Connector:
JST part # S06B-PASK-2

Mating Connector:
JST part # PAP-06V-S
Haydon Kerk part #56-1210-5

Wire to Board Connector:
JST part # SPHD-001T-P0.5

Series 28000 Size 11 with Integrated Connector

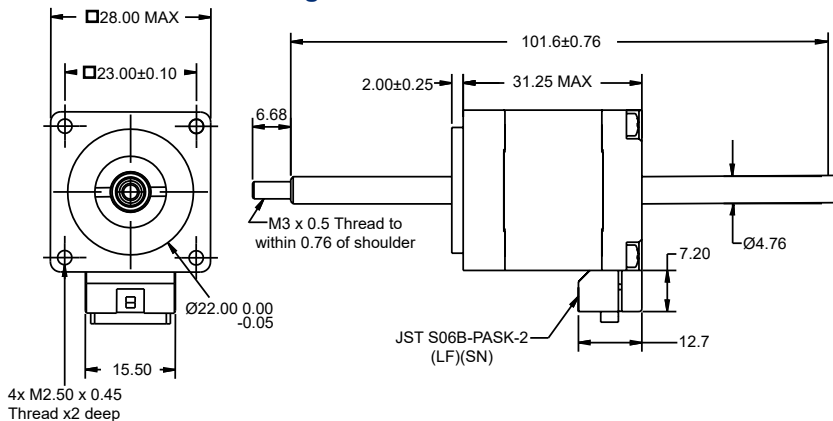



Series 35000 Size 14 with Integrated Connector

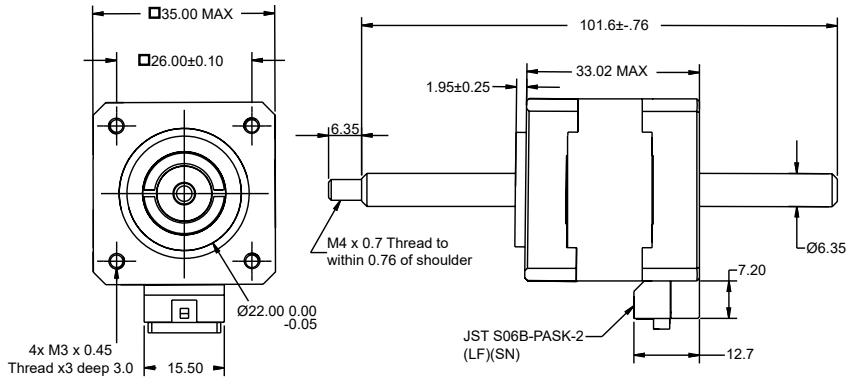

Series 43000 Size 17 with Integrated Connector

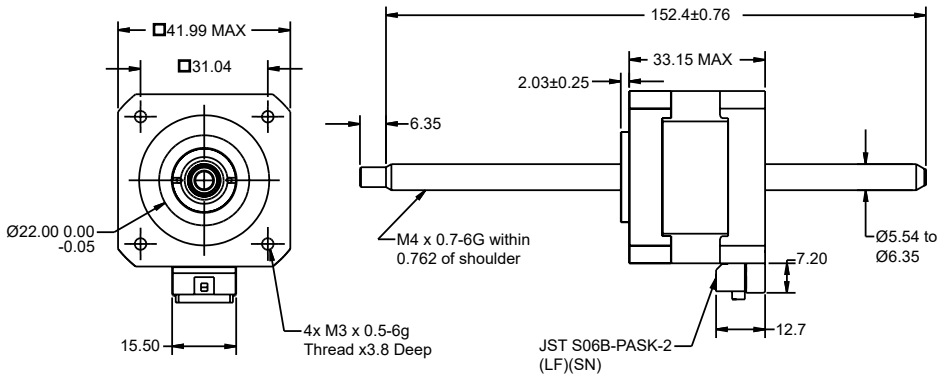





Can-stack linear actuators contain a threaded rotor with a leadscrew shaft able to drive linear motion in both directions. The pressed steel body encloses precise internal components, which means this design delivers an economic solution for electrically driven linear motion. Step increments vary with the step angle of the motor, combined with the pitch angle of the leadscrew, so each frame size has a range of step sizes available.

The large range of applications for this versatile product means it must accommodate a multitude of requirements; both a captive anti-rotation shaft and non-captive screw shaft are available, with an external linear option for most sizes. The motor is available in either unipolar or bipolar configuration. For higher load applications, rare earth magnets can be selected, and all frame sizes are built using dual ball bearings for high load capacity and long life. Most of the can-stack motor range are capable of micro-stepping for even finer resolution and performance optimisation.

G4 Series

The G4 Can-Stack series represents advanced motion control with the industry's most robust and powerful linear actuators. The series features:

- Enhanced teeth geometry
- High energy neodymium magnets
- Optimized magnetic circuit design
- High-tech engineered polymers
- Oversizes spline (captive)
- Large ball bearings

Available body-width diameters include Ø20 mm, 26 mm and 36 mm.



Can-Stack Series

Four basic frame sizes are available - Ø20 mm, Ø26 mm, Ø36 mm and Ø46 mm - as well as a series of extremely compact, Ø15 mm motors.

For finer steps, the High resolution 26000 and 36000 series features the smallest step capability in permanent magnet can-stack linear actuators.



Part number structure

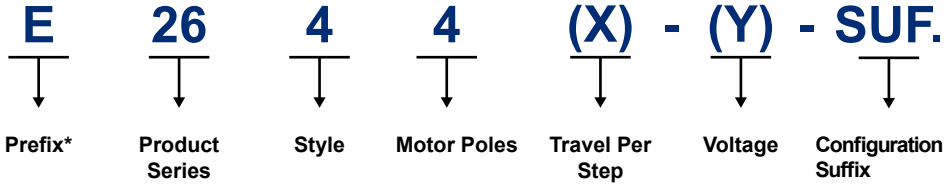

<p>*(Only when using the following)</p> <p>E = External Linear</p> <p>P = Proximity Senor</p> <p>S = Home Switch</p> <p>T = High Temperature</p> <p>N = Nema Flange (46000 Series Only)</p> <p>R = Rare Earth Magnet</p> <p>_ = None of the above</p>	<p>Available Hybrids</p> <p>19000 G4</p> <p>25000 G4</p> <p>37000 G4</p> <p>19000</p> <p>20000</p> <p>Z20000</p> <p>25000</p> <p>26000</p> <p>Z26000</p> <p>37000</p> <p>46000</p> <p>(Series numbers represents approximate diameters of motor body)</p>	<p>1 = 3.75° Non-captive</p> <p>2= 3.75° Captive</p> <p>3= 7.5° Non-captive</p> <p>4= 7.5° Captive</p> <p>4= 7.5° Captive</p> <p>Use "E" prefix for "External"</p> <p>5= 15° Captive</p> <p>5= 15° Captive</p> <p>Use "E" prefix for "External"</p> <p>8=15° Non-captive</p>	<p>4 = Bipolar (4 Wire)</p> <p>6 = Unipolar (6 Wire)</p>	<p>See 'Travel Selection' table on product page</p>	<p>See 'nomenclature' table on product page.</p>	<p>Select a 3 figure suffix to suit the application.</p> <p>See 'Configuration' table.</p> <p>-XXX = proprietary configuration assigned to a specific customer application. The identifier can apply to either a standard or custom part.</p>
--	--	--	--	---	--	---

Actuators



Wiring

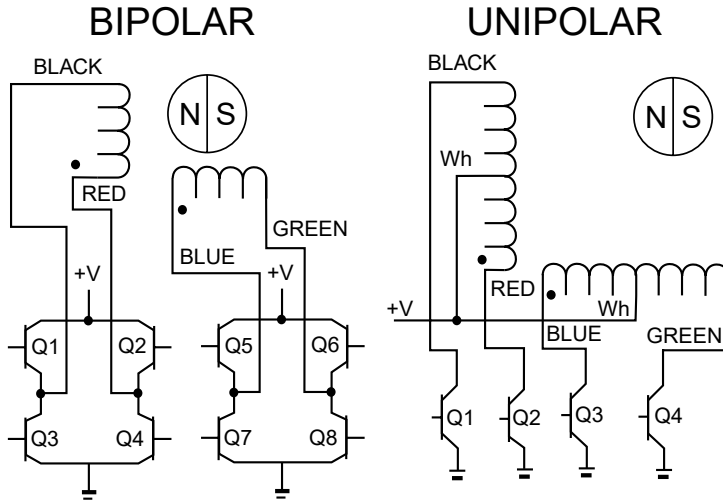

Actuators

Stepping Sequence

Bipolar	Q2-Q3	Q1-Q4	Q6-Q7	Q5-Q8
Unipolar	Q1	Q2	Q3	Q4
Step				
1	ON	OFF	ON	OFF
2	OFF	ON	ON	OFF
3	OFF	ON	OFF	ON
4	ON	OFF	OFF	ON
5	ON	OFF	ON	OFF

EXTEND CW ↓

RETRACT CW ↑

NOTE: Half stepping is accomplished by inserting an off state between transitioning phases.



All dimensions in mm

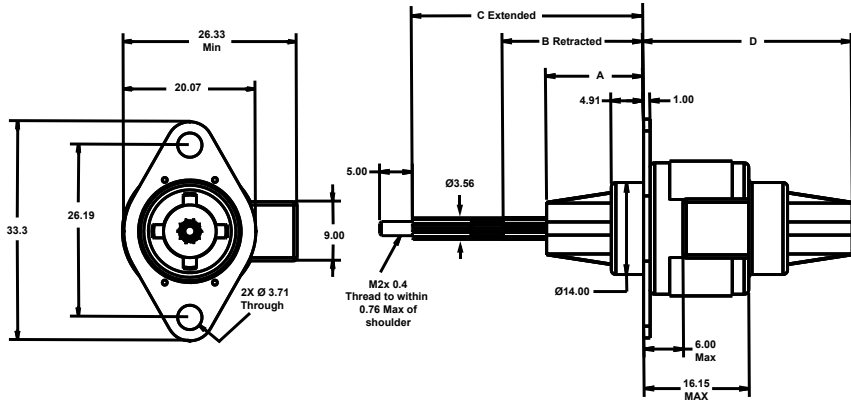

Actuators

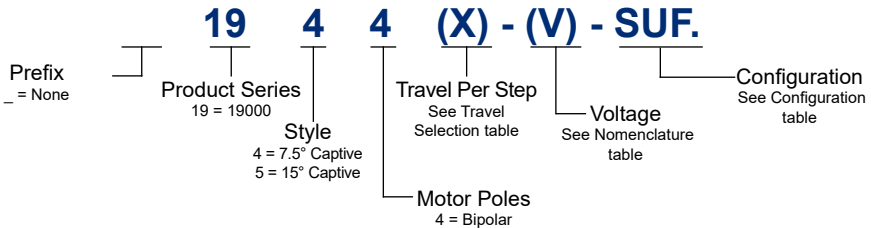

Technical Support

- Selection Guide : Page 1-01
- Product Overview : Page 1-144
- Performance curves : Page 1-154



Nomenclature

Ø20 mm Can-Stack Linear Actuator					
Part No.	Captive (4)	1944X-V-SUF	1954X-V-SUF		
Wiring		Bipolar (4 poles)			
Step Angle		7.5° (4)	15° (6)		
Winding Voltage (V)		5 VDC	12 VDC	5 VDC	12 VDC
Current (RMS)/ Phase		350mA	160mA	338mA	140mA
Resistance/ Phase		14.0 Ω	74.5 Ω	14.8 Ω	85.5 Ω
Inductance/ Phase		6.24 mH	31.2 mH	6.84 mH	37.8 mH

Motor Specification

Ø20 mm Can-Stack Linear Actuator		
Power consumption	3.38 W Total	
Rotor Inertia	1.052 gcm ²	0.548 gcm ²
Insulation Class	Class B	
Weight	355g	
Insulation Resistance	20MΩ	

Special drive considerations may be necessary when leaving shaft fully extended or fully retracted.

Standard motors are Class B rated for maximum temperature of 130°C.

Travel Selection

Linear Travel/ Step	0.013		
Step Angle 7.5°			
Part No (X)	3		
Linear Travel/Step	0.0254	0.051	0.102
Step Angle 15°			
Part No (X)	1	2	4

Configuration

Stroke (Minimum)	Front Sleeve A	Retracted B	Extended C	Rear Sleeve D	SUF.
13 mm	14.75±0.25	21.37±0.64	35.17±0.38	32.08 MAX	- 905
18 mm	20.05±0.25	26.67±0.64	45.77±0.38	37.38 MAX	- 907
25 mm	27.05±0.25	33.67±0.64	59.77±0.38	44.38 MAX	- 910
31 mm	33.05±0.25	39.67±0.64	71.77±0.38	63.08 MAX	- 912



All dimensions in mm

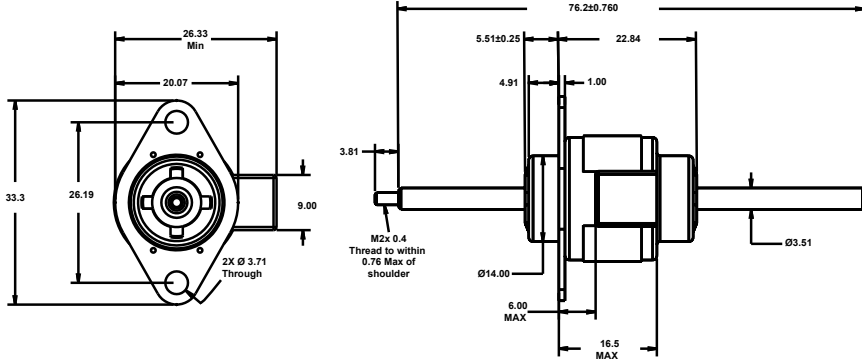

Actuators

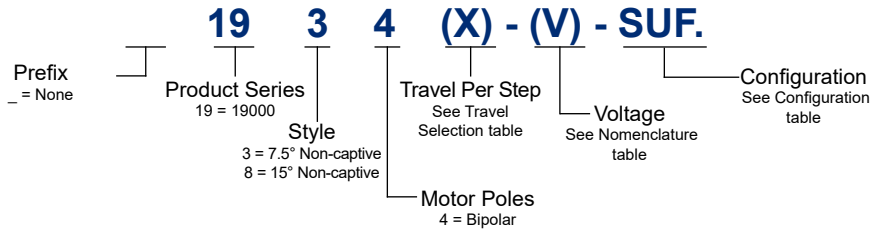

Technical Support

- Selection Guide : Page 1-01
- Product Overview : Page 1-144
- Performance curves : Page 1-154





Nomenclature

Ø20 mm Can-Stack Linear Actuator					
Part No.	Non-captive (3)	1934X-V-SUF	1984X-V-SUF		
Wiring		Bipolar (4 poles)			
Step Angle		7.5° (3)	15° (8)		
Winding Voltage (V)		5 VDC	12 VDC	5 VDC	12 VDC
Current (RMS)/ Phase		350mA	160mA	338mA	140mA
Resistance/ Phase		14.0 Ω	74.5 Ω	14.8 Ω	85.5 Ω
Inductance/ Phase		6.24 mH	31.2 mH	6.84 mH	37.8 mH

Motor Specification

Ø20 mm Can-Stack Linear Actuator		
Power consumption	3.38 W Total	
Rotor Inertia	1.052 gcm ²	0.548 gcm ²
Insulation Class	Class B	
Weight	355g	
Insulation Resistance	20MΩ	

Special drive considerations may be necessary when leaving shaft fully extended or fully retracted.

Standard motors are Class B rated for maximum temperature of 130°C.

Travel Selection

Linear Travel/ Step	0.013		
Step Angle 7.5°			
Part No (X)	3		
Linear Travel/Step	0.0254	0.051	0.102
Step Angle 15°			
Part No (X)	1	2	4

Connector

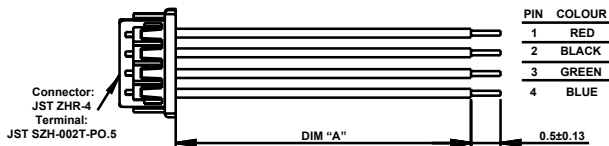

Part No.	Dimension "A"
56-1318-4	610 ±10 mm
56-1318-3	450 ±10 mm
56-1318-2	305 ±10 mm
56-1318-1	150 ±10 mm



All dimensions in mm

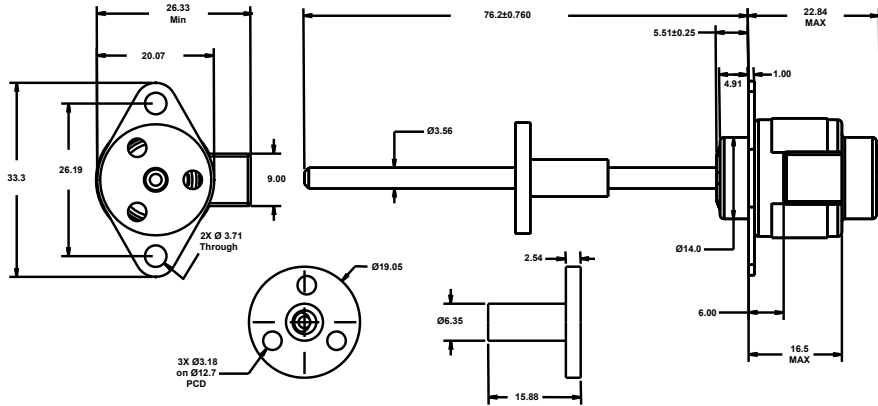

Actuators

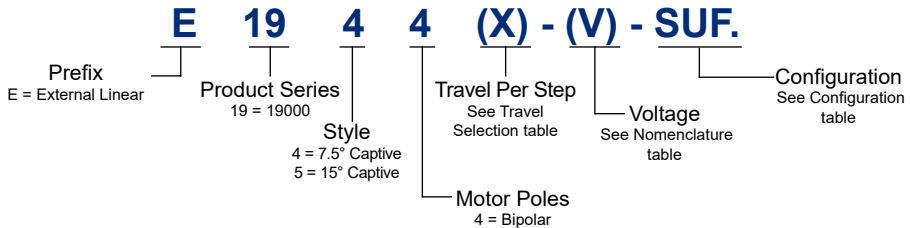

Technical Support

- Selection Guide : Page 1-01
- Product Overview : Page 1-144
- Performance curves : Page 1-154





Nomenclature

Ø20 mm Can-Stack Linear Actuator				
Part No.	External linear (4)	E1944X-V-SUF		E1954X-V-SUF
Wiring		Bipolar (4 poles)		
Step Angle		7.5° (4)		15° (5)
Winding Voltage (V)		5 VDC	12 VDC	5 VDC 12 VDC
Current (RMS)/ Phase		350 mA	160 mA	338 mA 140 mA
Resistance/ Phase		14.0 Ω	74.5 Ω	14.8 Ω 85.5 Ω
Inductance/ Phase		6.24 mH	31.2 mH	6.84 mH 37.8 mH

Motor Specification

Ø20 mm Can-Stack Linear Actuator		
Power consumption	3.38 W Total	
Rotor Inertia	1.052 gcm ²	0.548 gcm ²
Insulation Class	Class B	
Weight	355g	
Insulation Resistance	20MΩ	

Special drive considerations may be necessary when leaving shaft fully extended or fully retracted.

Standard motors are Class B rated for maximum temperature of 130°C.

Travel Selection

Linear Travel/ Step	0.013		
Step Angle 7.5°			
Part No (X)	3		
Linear Travel/Step	0.0254	0.051	0.102
Step Angle 15°			
Part No (X)	1	2	4



Force vs. Pulse Rate Bipolar. L/R Drive. 100% Duty Cycle

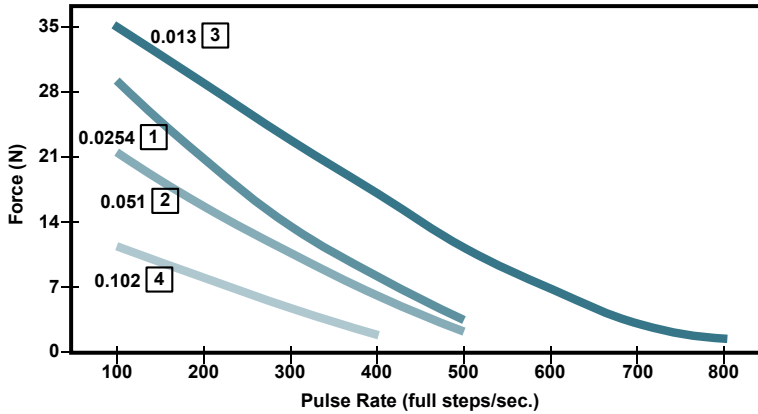

Force vs. Pulse Rate Bipolar. L/R Drive. 25% Duty Cycle

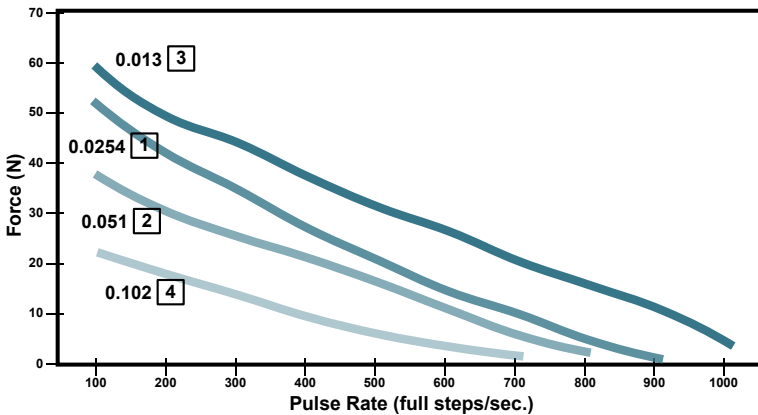



Force vs. Pulse Rate Bipolar. Chopper. 100% Duty Cycle

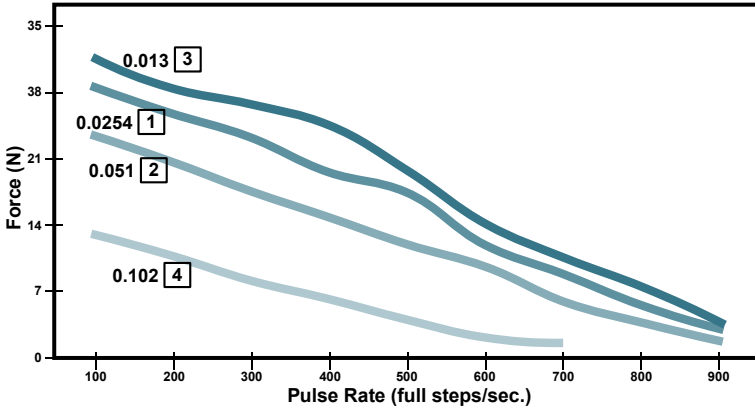

Force vs. Pulse Rate Bipolar. Chopper. 25% Duty Cycle

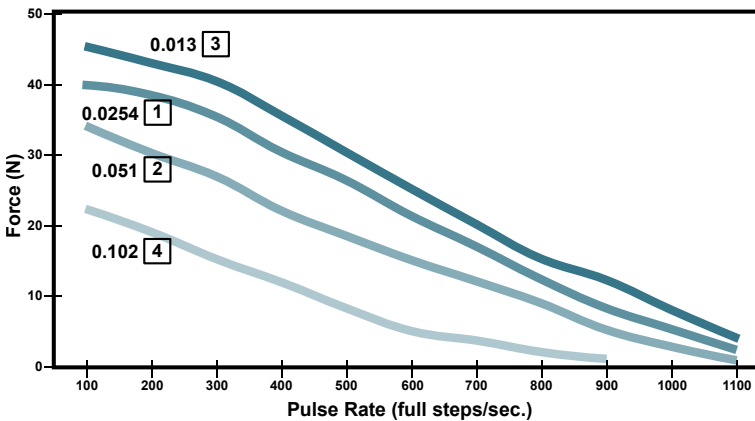

Note: All chopper drive curves were created with a 5 Volt motor and a 40 Volt power supply

Ramping can increase the performance of a motor either by increasing the top speed or getting heavier load accelerated up to speed faster. Also, deceleration can be used to stop the motor without overshoot.

Actuators



All dimensions in mm

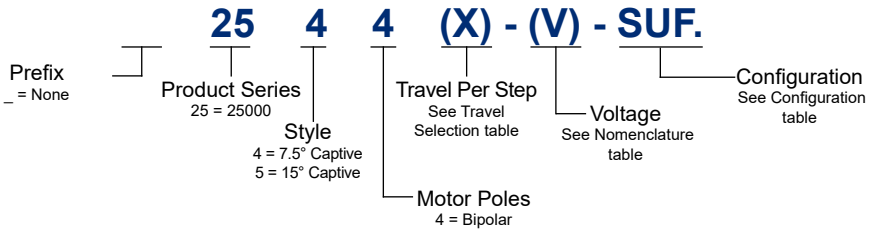
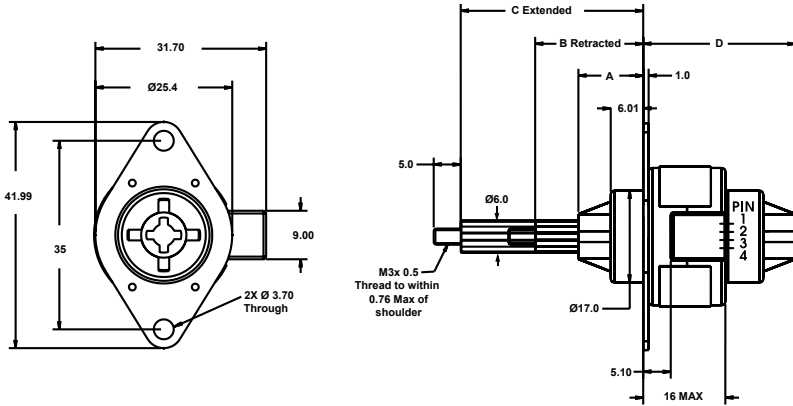

Actuators

Technical Support

- Selection Guide : Page 1-01
- Product Overview : Page 1-144
- Performance curves : Page 1-162





Nomenclature

Ø25 mm Can-Stack Linear Actuator					
Part No.	Captive (4)	2544X-V-SUF	2554X-V-SUF		
Wiring		Bipolar (4 poles)			
Step Angle		7.5° (4)	15° (5)		
Winding Voltage (V)		5 VDC	12 VDC	5 VDC	12 VDC
Current (RMS)/ Phase		385mA	160mA	385mA	160mA
Resistance/ Phase		13 Ω	72 Ω	13 Ω	72 Ω
Inductance/ Phase		10.8mH	60mH	8.08mH	48mH

Motor Specification

Ø25 mm Can-Stack Linear Actuator	
Power consumption	3.85 W Total
Rotor Inertia	1.07 gcm ²
Insulation Class	Class B
Weight	49g
Insulation Resistance	20MΩ

Special drive considerations may be necessary when leaving shaft fully extended or fully retracted.

Standard motors are Class B rated for maximum temperature of 130°C.

Travel Selection

Linear Travel/ Step	0.013	0.0254	0.051
Step Angle 7.5°			
Part No (X)	3	1	2
Linear Travel/Step	0.0254	0.051	0.102
Step Angle 15°			
Part No (X)	1	2	4

Configuration

Stroke (Minimum)	Front Sleeve A	Retracted B	Extended C	Rear Sleeve D	SUF.
13mm	11.99±0.25	19.99±0.64	33.76±0.38	28.65 MAX	- 905
18mm	17.28±0.25	25.25±0.64	44.27±0.38	33.94 MAX	- 907
25mm	24.26±0.25	32.23±0.64	58.24±0.38	40.92 MAX	- 910
31mm	30.25±0.25	38.23±0.64	70.23±0.38	46.91 MAX	- 912



All dimensions in mm

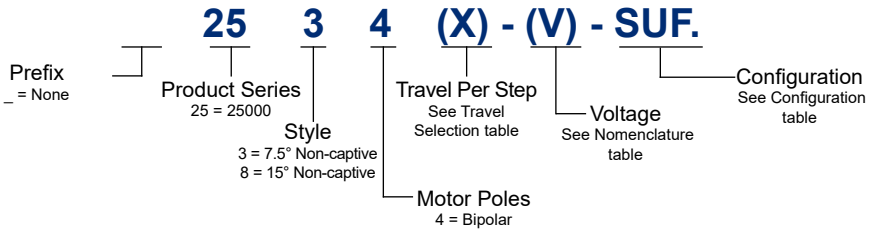
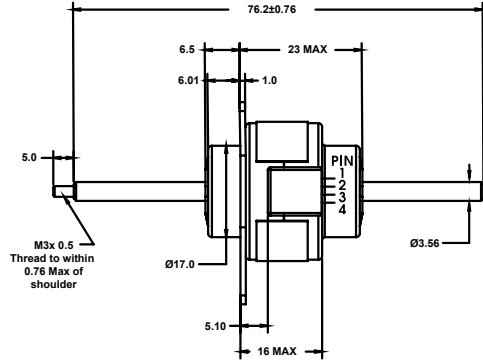
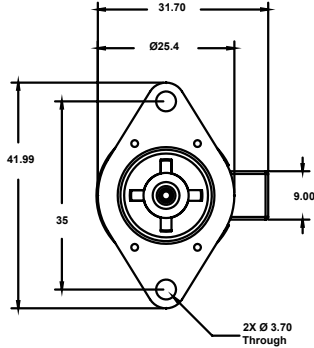

Actuators

Technical Support

- Selection Guide : Page 1-01
- Product Overview : Page 1-144
- Performance curves : Page 1-162





Nomenclature

Ø25 mm Can-Stack Linear Actuator					
Part No.	Non-captive (3)	2534X-V-SUF		2584X-V-SUF	
Wiring		Bipolar (4 poles)			
Step Angle		7.5° (3)		15° (8)	
Winding Voltage (V)		5 VDC	12 VDC	5 VDC	12 VDC
Current (RMS)/ Phase		385 mA	160 mA	385 mA	160 mA
Resistance/ Phase		13 Ω	72 Ω	13 Ω	72 Ω
Inductance/ Phase		10.8mH	60mH	8.08mH	48mH

Motor Specification

Ø25 mm Can-Stack Linear Actuator	
Power consumption	3.85 W Total
Rotor Inertia	1.07 gcm ²
Insulation Class	Class B
Weight	49g
Insulation Resistance	20MΩ

Special drive considerations may be necessary when leaving shaft fully extended or fully retracted.

Standard motors are Class B rated for maximum temperature of 130°C.

Travel Selection

Linear Travel/ Step	0.013	0.0254	0.051
Step Angle 7.5°			
Part No (X)	3	1	2
Linear Travel/Step	0.0254	0.051	0.102
Step Angle 15°			
Part No (X)	1	2	4

Connector

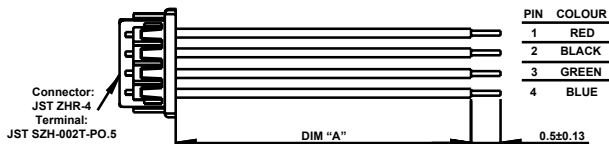

Part No.	Dimension "A"
56-1318-4	610 ±10 mm
56-1318-3	450 ±10 mm
56-1318-2	305 ±10 mm
56-1318-1	150 ±10 mm



All dimensions in mm

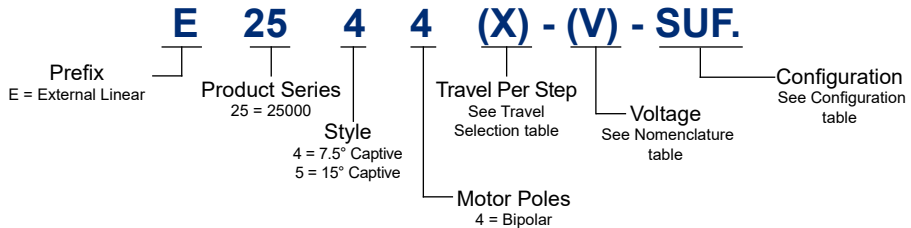
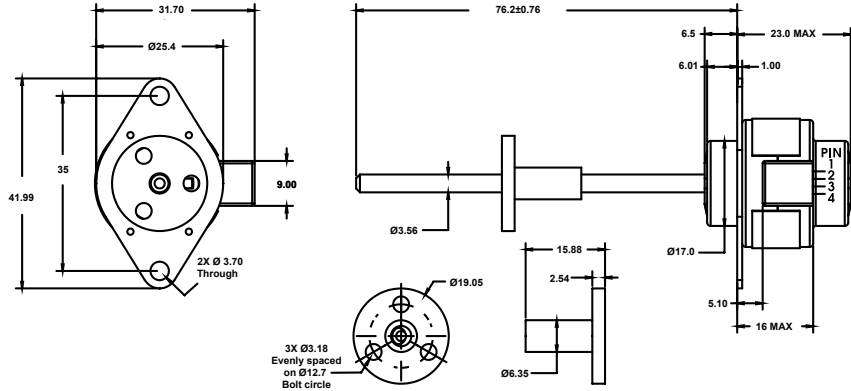

Actuators

Technical Support

- Selection Guide : Page 1-01
- Product Overview : Page 1-144
- Performance curves : Page 1-162





Nomenclature

Ø25 mm Can-Stack Linear Actuator				
Part No.	External Linear (4)	E2544X-V-SUF		E2554X-V-SUF
Wiring		Bipolar (4 poles)		
Step Angle		7.5° (4)		15° (5)
Winding Voltage (V)		5 VDC	12 VDC	5 VDC 12 VDC
Current (RMS)/ Phase		385 mA	160 mA	385 mA 160 mA
Resistance/ Phase		13 Ω	72 Ω	13 Ω 72 Ω
Inductance/ Phase		10.8mH	60mH	8.08mH 48mH

Motor Specification

Ø25 mm Can-Stack Linear Actuator	
Power consumption	3.85 W Total
Rotor Inertia	1.07 gcm ²
Insulation Class	Class B
Weight	49g
Insulation Resistance	20MΩ

Special drive considerations may be necessary when leaving shaft fully extended or fully retracted.

Standard motors are Class B rated for maximum temperature of 130°C.

Travel Selection

Linear Travel/ Step	0.013	0.0254	0.051
Step Angle 7.5°			
Part No (X)	3	1	2
Linear Travel/Step	0.0254	0.051	0.102
Step Angle 15°			
Part No (X)	1	2	4



Force vs. Pulse Rate Bipolar. L/R Drive. 100% Duty Cycle

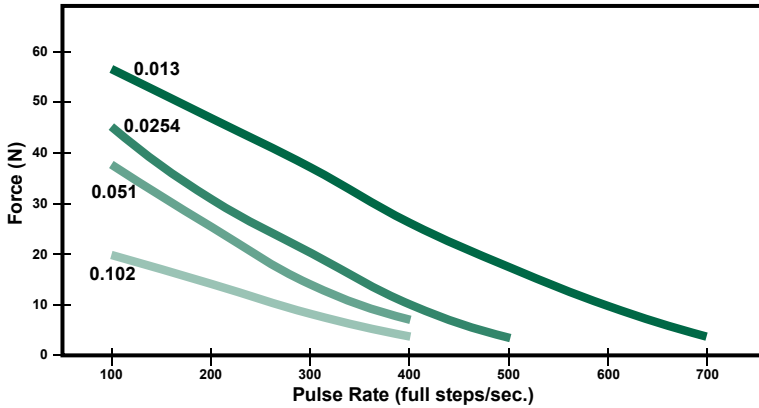

Force vs. Pulse Rate Bipolar. L/R Drive. 25% Duty Cycle

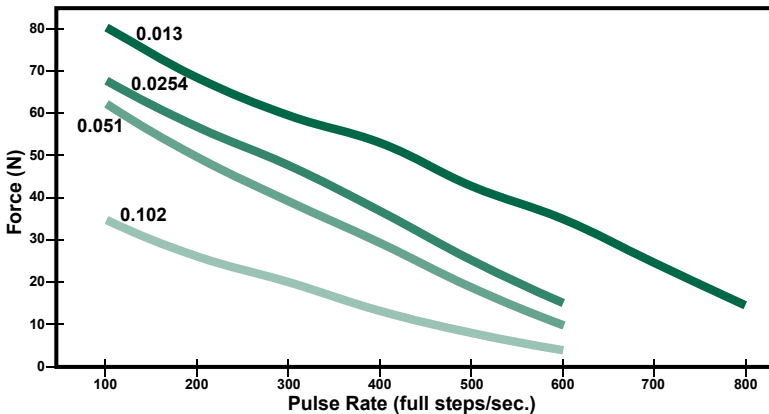



Force vs. Pulse Rate Bipolar. Chopper. 100% Duty Cycle

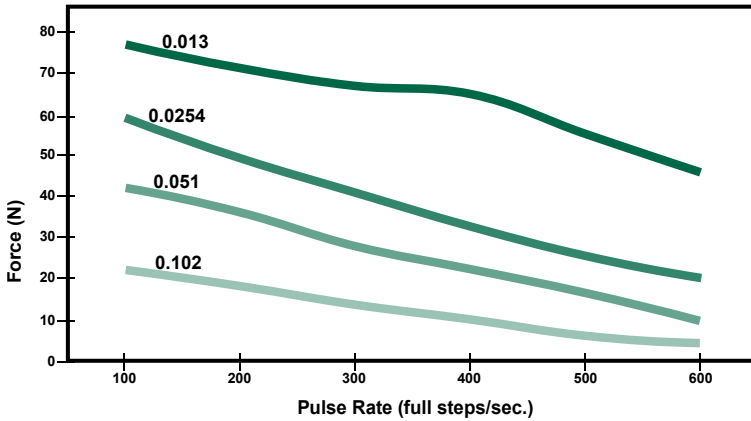

Force vs. Pulse Rate Bipolar. Chopper. 25% Duty Cycle

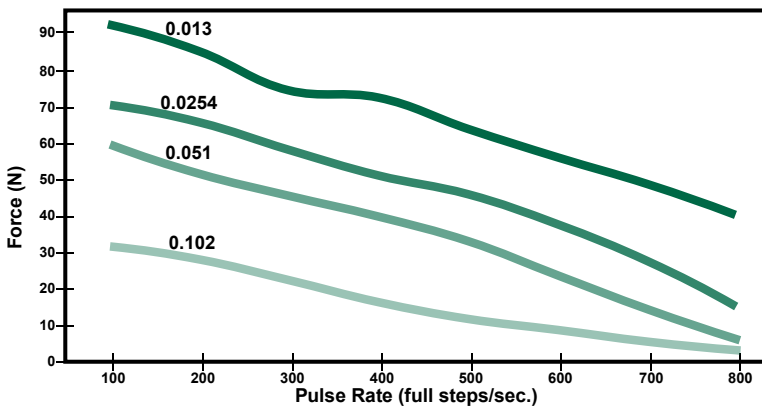

Note: All chopper drive curves were created with a 5 Volt motor and a 40 Volt power supply

Ramping can increase the performance of a motor either by increasing the top speed or getting heavier load accelerated up to speed faster. Also, deceleration can be used to stop the motor without overshoot.

Actuators



All dimensions in mm

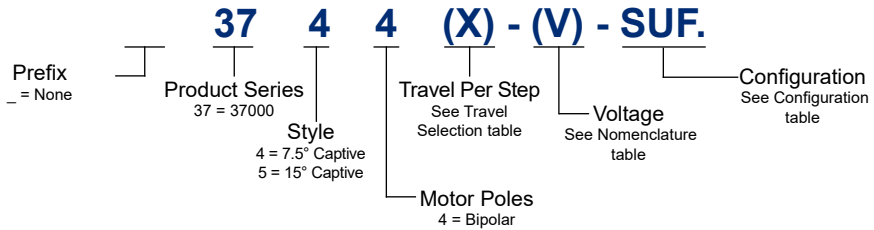
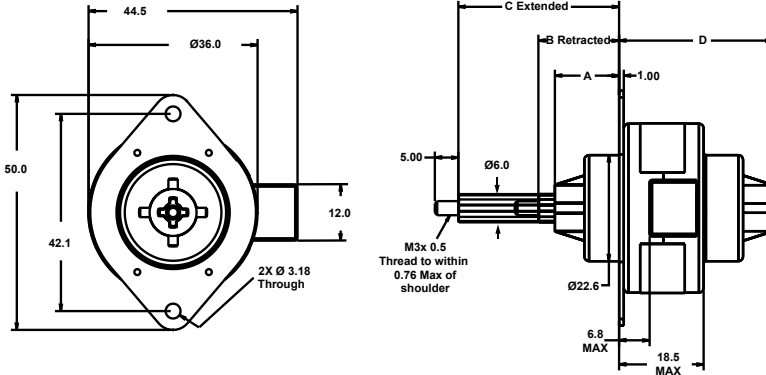

Technical Support

- Selection Guide : Page 1-01
- Product Overview : Page 1-144
- Performance curves : Page 1-170



Nomenclature

Ø36 mm Can-Stack Linear Actuator					
Part No.	Captive (4)	3744X-V-SUF		3754X-V-SUF	
Wiring		Bipolar (4 poles)			
Step Angle		7.5° (4)		15° (5)	
Winding Voltage (V)		5 VDC	12 VDC	5 VDC	12 VDC
Current (RMS)/ Phase		561 mA	230 mA	561 mA	230 mA
Resistance/ Phase		8.9 Ω	52 Ω	8.9 Ω	52 Ω
Inductance/ Phase		11.6mH	65mH	8.5mH	46mH

Motor Specification

Ø36 mm Can-Stack Linear Actuator	
Power consumption	5.6 W Total
Rotor Inertia	8.5 gcm ²
Insulation Class	Class B
Weight	49g
Insulation Resistance	20MΩ

Special drive considerations may be necessary when leaving shaft fully extended or fully retracted.

Standard motors are Class B rated for maximum temperature of 130°C.

Travel Selection

Linear Travel/ Step	0.013	0.0254	0.051
Step Angle 7.5°			
Part No (X)	3	1	2
Linear Travel/Step	0.0254	0.051	0.102
Step Angle 15°			
Part No (X)	1	2	4

Configuration

Stroke (Minimum)	Front Sleeve A	Retracted B	Extended C	Rear Sleeve D	SUF.
16mm	13.67±0.25	17.19±0.64	34.24±0.38	28.65 MAX	- 905
25.4mm	26.37±0.25	29.89±0.64	56.94±0.38	33.94 MAX	- 910
38.1mm	39.07±0.25	42.59±0.64	85.04±0.38	40.92 MAX	- 915



All dimensions in mm

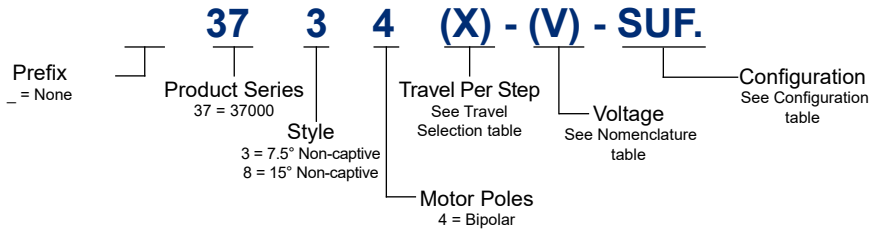
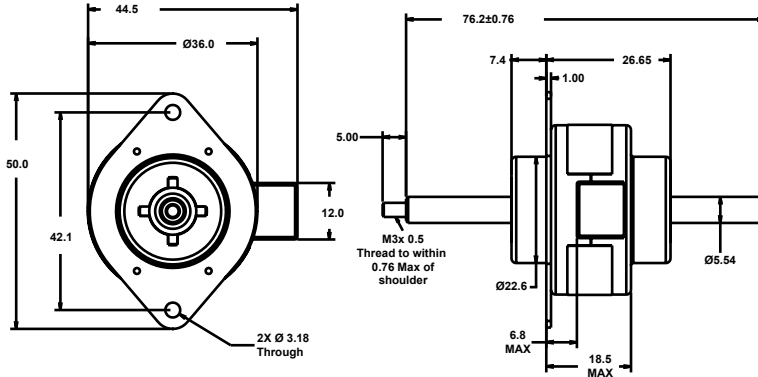

Actuators



Technical Support

- Selection Guide : Page 1-01
- Product Overview : Page 1-144
- Performance curves : Page 1-170



Nomenclature

Ø36 mm Can-Stack Linear Actuator					
Part No.	Non-captive (3)	3734X-V-SUF		3784X-V-SUF	
Wiring		Bipolar (4 poles)			
Step Angle		7.5° (3)		15° (8)	
Winding Voltage (V)		5 VDC	12 VDC	5 VDC	12 VDC
Current (RMS)/ Phase		561 mA	230 mA	561 mA	230 mA
Resistance/ Phase		8.9 Ω	52 Ω	8.9 Ω	52 Ω
Inductance/ Phase		11.6mH	65mH	8.5mH	46mH

Motor Specification

Ø36 mm Can-Stack Linear Actuator	
Power consumption	5.6 W Total
Rotor Inertia	8.5 gcm ²
Insulation Class	Class B
Weight	49g
Insulation Resistance	20MΩ

Special drive considerations may be necessary when leaving shaft fully extended or fully retracted.

Standard motors are Class B rated for maximum temperature of 130°C.

Travel Selection

Linear Travel/ Step	0.013	0.0254	0.051
Step Angle 7.5°			
Part No (X)	3	1	2
Linear Travel/Step	0.0254	0.051	0.102
Step Angle 15°			
Part No (X)	1	2	4

Connector

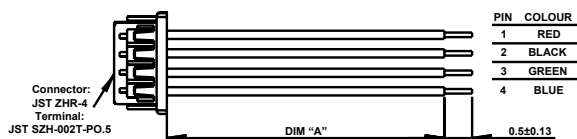

Part No.	Dimension "A"
56-1436-1	152 ±10 mm
56-1436-2	305 ±10 mm



**37000
Series**

G4 Series Ø36 mm Can-Stack External Linear

All dimensions in mm

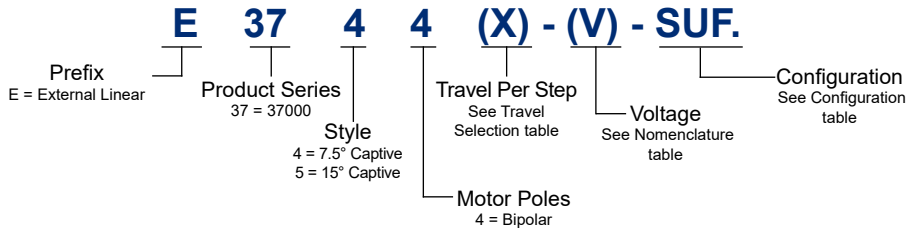
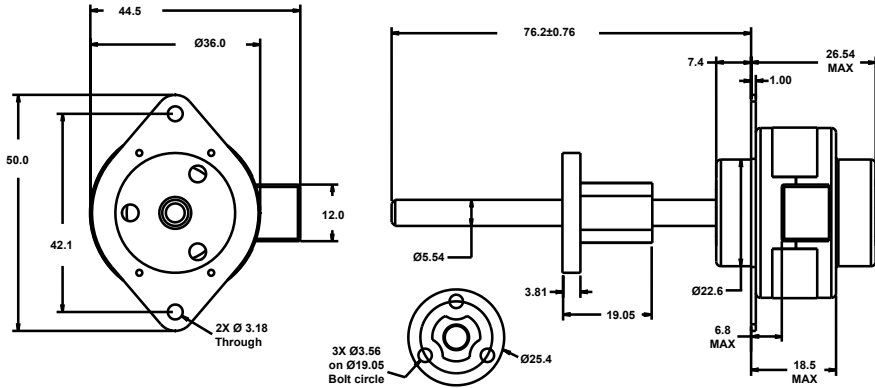

Actuators



Technical Support

- Selection Guide : Page 1-01
- Product Overview : Page 1-144
- Performance curves : Page 1-170



Nomenclature

Ø36 mm Can-Stack Linear Actuator				
Part No.	External Linear (4)	E3744X-V-SUF		E3754X-V-SUF
Wiring		Bipolar (4 poles)		
Step Angle		7.5° (4)		15° (5)
Winding Voltage (V)		5 VDC	12 VDC	5 VDC 12 VDC
Current (RMS)/ Phase		561 mA	230 mA	561 mA 230 mA
Resistance/ Phase		8.9 Ω	52 Ω	8.9 Ω 52 Ω
Inductance/ Phase		11.6mH	65mH	8.5mH 46mH

Motor Specification

Ø36 mm Can-Stack Linear Actuator	
Power consumption	5.6 W Total
Rotor Inertia	8.5 gcm ²
Insulation Class	Class B
Weight	49g
Insulation Resistance	20MΩ

Special drive considerations may be necessary when leaving shaft fully extended or fully retracted.

Standard motors are Class B rated for maximum temperature of 130°C.

Travel Selection

Linear Travel/ Step	0.013	0.0254	0.051
Step Angle 7.5°			
Part No (X)	3	1	2
Linear Travel/Step	0.0254	0.051	0.102
Step Angle 15°			
Part No (X)	1	2	4



Force vs. Pulse Rate Bipolar. L/R Drive. 100% Duty Cycle

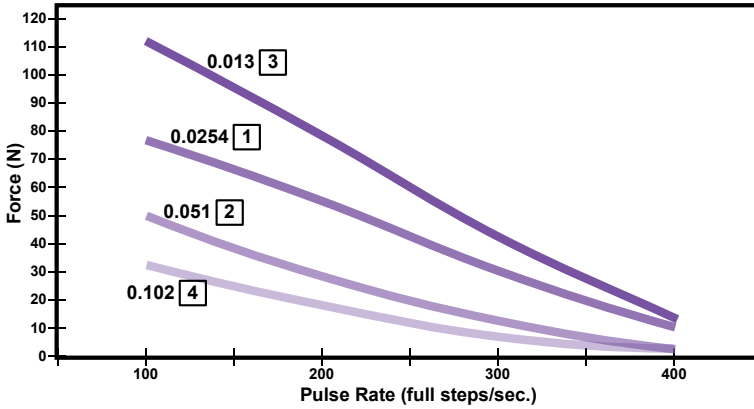

Force vs. Pulse Rate Bipolar. L/R Drive. 25% Duty Cycle

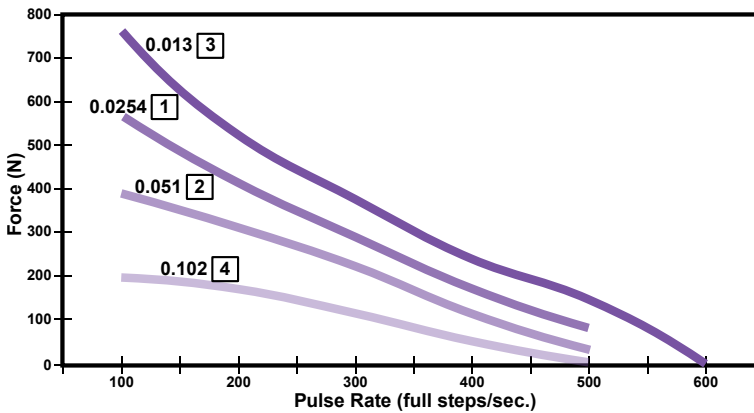



Force vs. Pulse Rate Bipolar. Chopper. 100% Duty Cycle

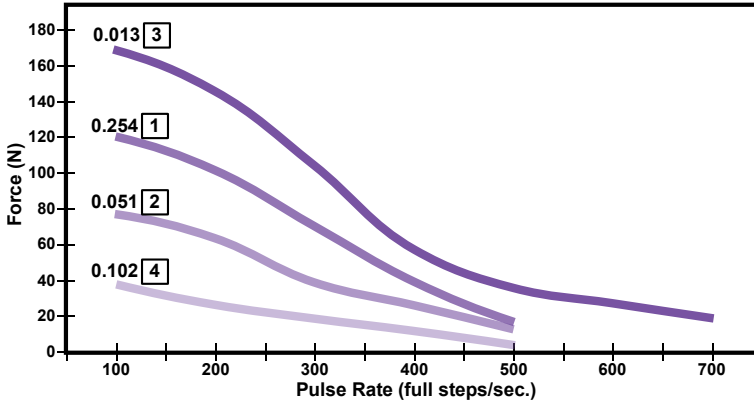

Force vs. Pulse Rate Bipolar. Chopper. 25% Duty Cycle

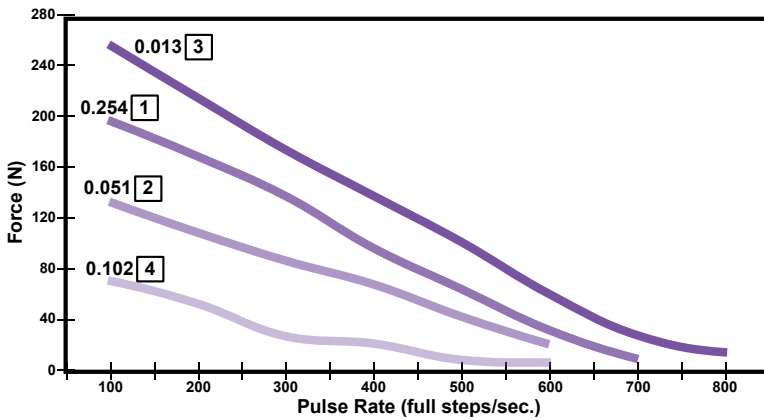

Note: All chopper drive curves were created with a 5 Volt motor and a 40 Volt power supply

Ramping can increase the performance of a motor either by increasing the top speed or getting heavier load accelerated up to speed faster. Also, deceleration can be used to stop the motor without overshoot.

Actuators



The 15000 series linear stepper motor delivers straight line motion in both directions, supported by ball bearings in both captive and external linear versions. This compact and light weight design is just 15mm in overall diameter.



Connector Information

Connectors	PIN			
	1	2	3	4
JST PHR-4	Red	White	Green	Black
Molex 51021-0400	Black	Green	White	Red

Connectors Selection

Standard Connectors Available	JST PHR-4
	304.8 mm flying leads
	Molex 51021-0400

Actuators



Wiring

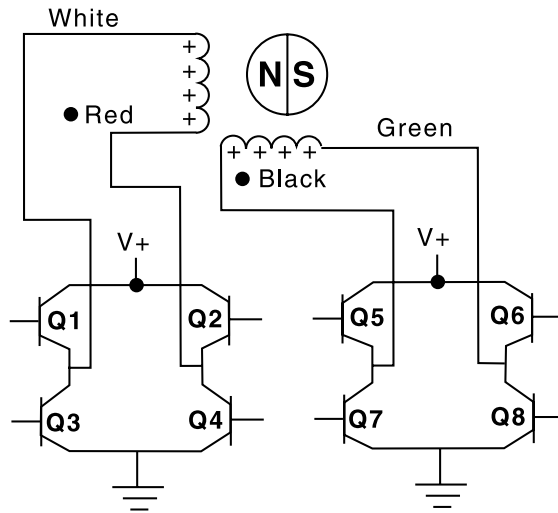

Stepping Sequence

	Bipolar	Q2-Q3	Q1-Q4	Q6-Q7	Q5-Q8
	Unipolar	Q1	Q2	Q3	Q4
	Step				
EXTEND CW ↓	1	ON	OFF	ON	OFF
	2	OFF	ON	ON	OFF
	3	OFF	ON	OFF	ON
	4	ON	OFF	OFF	ON
					RETRACT CW ↑

NOTE: Half stepping is accomplished by inserting an off state between transitioning phases.



All dimensions in mm

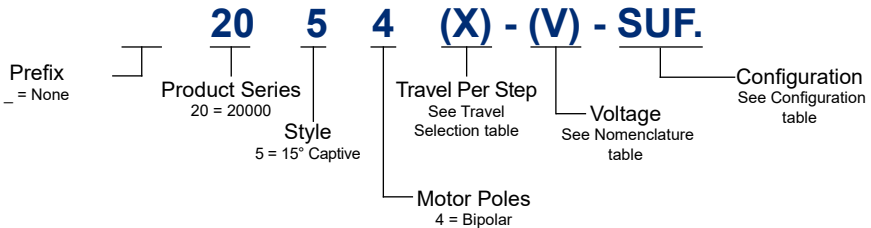
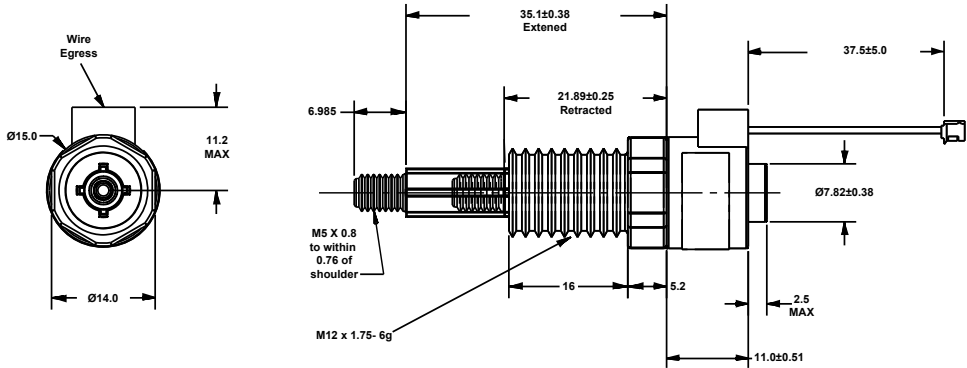

Technical Support

- Selection Guide : Page 1-01
- Product Overview : Page 1-172
- Performance curves : Page 1-178



Actuators



Nomenclature

Ø15 mm Can-Stack Linear Actuator			
Part No.	Captive	LC1574X-V-SUF	
Wiring		Bipolar (4 poles)	
Step Angle		18°	
Winding Voltage (V)	4 VDC	5 VDC	12 VDC
Current (RMS)/ Phase	0.2A	0.16A	0.07A
Resistance/ Phase	20 Ω	31 Ω	180 Ω
Inductance/ Phase	5.6mH	8.7mH	48.8mH

Motor Specification

Ø36 mm Can-Stack Linear Actuator	
Power consumption	1.6 W Total
Rotor Inertia	0.09 gcm ²
Insulation Class	Class B
Weight	28g
Insulation Resistance	100MΩ
Stroke	12.7mm

Special drive considerations may be necessary when leaving shaft fully extended or fully retracted.

Standard motors are Class B rated for maximum temperature of 130°C.

Travel Selection

Linear Travel/ Step	0.02	0.025	0.05	0.10
Step Angle 18°				
Part No (X)	W	AQ	BH	DC

Flying leads

Length	Order Code I.D.
mm	(Add to end on I.D.)
304.8	- 999

Note: All supplied with JST connector as standard



All dimensions in mm

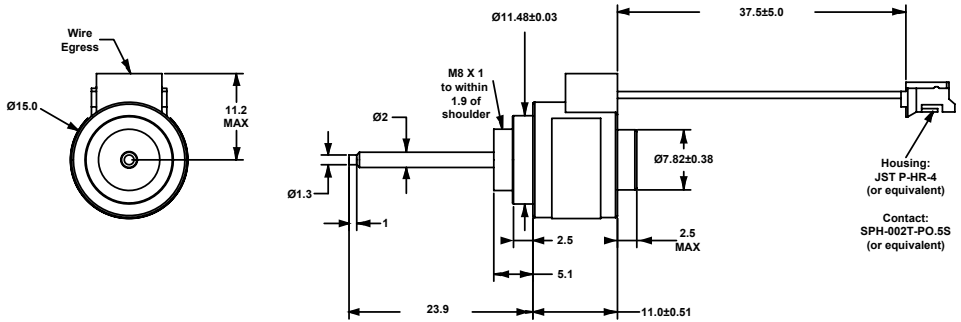

Technical Support

- Selection Guide : Page 1-01
- Product Overview : Page 1-172
- Performance curves : Page 1-178

Actuators



Nomenclature

Ø15 mm Can-Stack Linear Actuator			
Part No.	External Linear	LE1574X-V-SUF	
Wiring		Bipolar (4 poles)	
Step Angle		18°	
Winding Voltage (V)	4 VDC	5 VDC	12 VDC
Current (RMS)/ Phase	0.2A	0.16A	0.07A
Resistance/ Phase	20 Ω	31 Ω	180 Ω
Inductance/ Phase	5.6mH	8.7mH	48.8mH

Motor Specification

Ø36 mm Can-Stack Linear Actuator	
Power consumption	1.6 W Total
Rotor Inertia	0.09 gcm ²
Insulation Class	Class B
Weight	28g
Insulation Resistance	100MΩ
Stroke	12.7mm

Special drive considerations may be necessary when leaving shaft fully extended or fully retracted.

Standard motors are Class B rated for maximum temperature of 130°C.

Travel Selection

Linear Travel/ Step	0.02	0.025	0.05	0.10
Step Angle 18°				
Part No (X)	W	AQ	BH	DC

Flying leads

Length	Order Code I.D. (Add to end on I.D.)
mm	
304.8	- 999

Note: All supplied with JST connector as standard



Force vs. Pulse Rate Bipolar. L/R Drive. 100% Duty Cycle

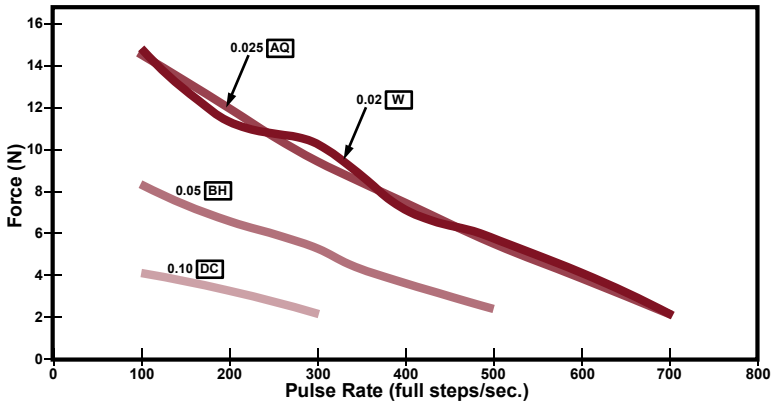

Force vs. Pulse Rate Bipolar. L/R Drive. 25% Duty Cycle

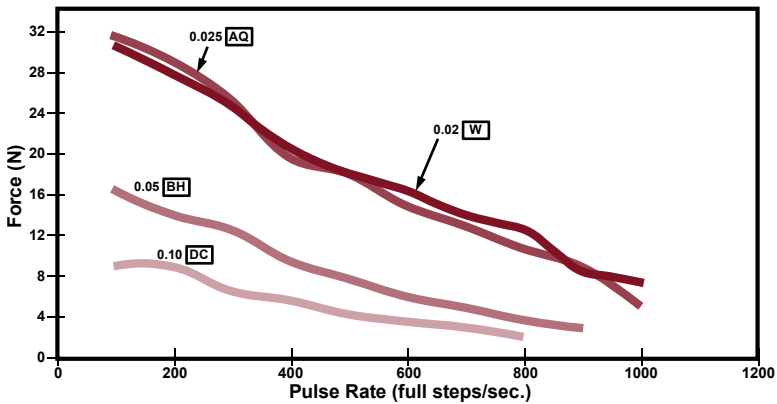



Force vs. Pulse Rate Chopper Drive. Bipolar. 100% Duty Cycle

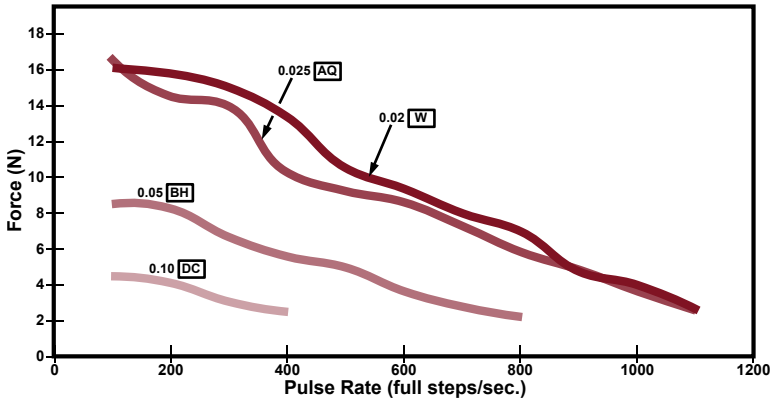

Force vs. Pulse Rate Chopper Drive. Bipolar. 25% Duty Cycle

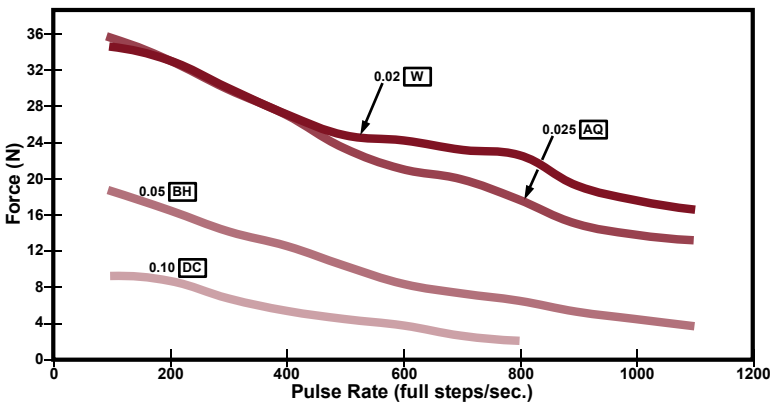

Note: Ramping can increase the performance of a motor either by increasing the top speed or getting heavier load accelerated up to speed faster. Also, deceleration can be used to stop the motor without overshoot.



All dimensions in mm

Actuators

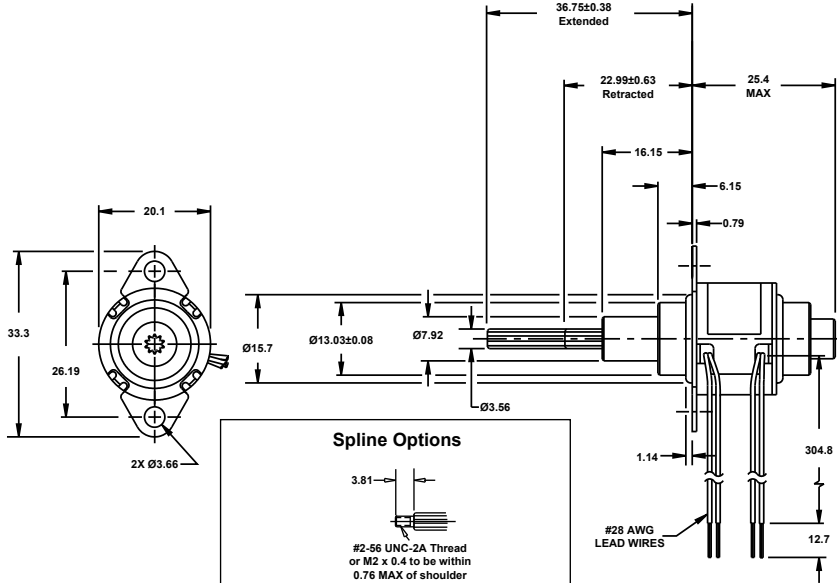

Spline Options

#2-56 UNC-2A Thread or M2 x 0.4 to be within 0.76 MAX of shoulder

Spline is also available with optional #4-40 UNC-2A or M3 x 0.5 threaded adapter as shown in non-captive drawing.

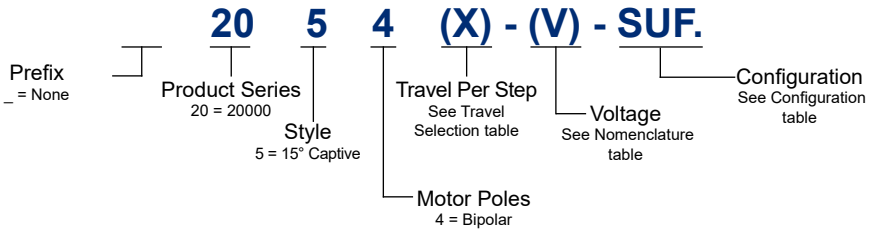

Technical Support

- Selection Guide : Page 1-01
- Product Overview : Page 1-144
- Performance curves : Page 1-184



Nomenclature

Ø20 mm Can-Stack Linear Actuator		
Part No.	Captive (4)	2054X-V-SUF
Wiring		Bipolar (4 poles)
Step Angle		15° (4)
Winding Voltage (V)		5 VDC 12 VDC
Current (RMS)/ Phase		270mA 113mA
Resistance/ Phase		18.5 Ω 106 Ω
Inductance/ Phase		5.5mH 32mH

Motor Specification

Ø20 mm Can-Stack Linear Actuator	
Power consumption	2.7 W Total
Rotor Inertia	0.5 gcm ²
Insulation Class	Class B
Weight	28g
Insulation Resistance	20MΩ

Special drive considerations may be necessary when leaving shaft fully extended or fully retracted.

Standard motors are Class B rated for maximum temperature of 130°C.

Travel Selection

Linear Travel/ Step	0.0254	0.051	0.102
Step Angle 15°			
Part No (X)	1	2	4



All dimensions in mm

Actuators

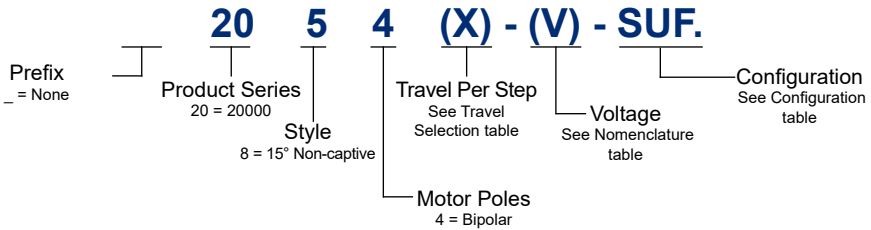
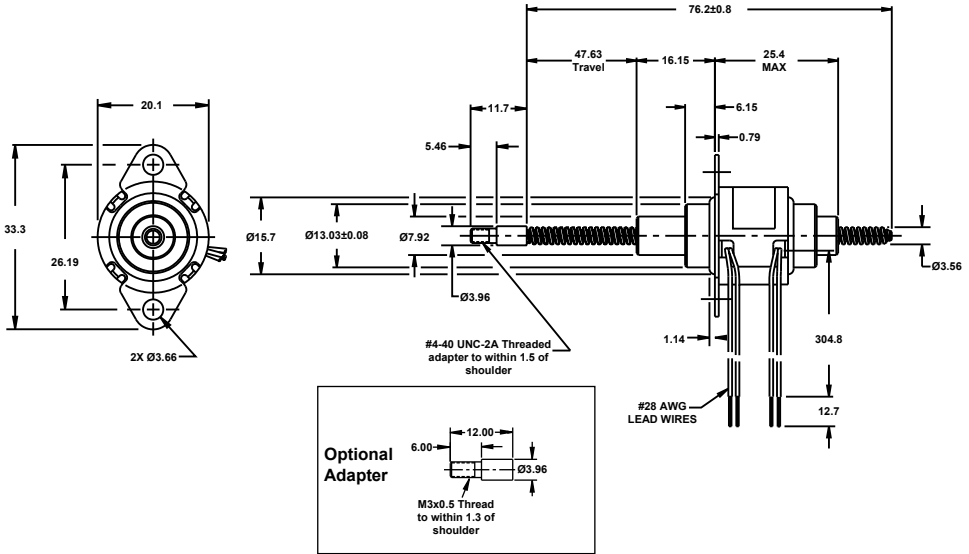

Technical Support

- Selection Guide : Page 1-01
- Product Overview : Page 1-144
- Performance curves : Page 1-184



Nomenclature

Ø20 mm Can-Stack Linear Actuator		
Part No.	Non-captive (8)	2084X-V-SUF
Wiring		Bipolar (4 poles)
Step Angle		15° (8)
Winding Voltage (V)		5 VDC 12 VDC
Current (RMS)/ Phase		270mA 113mA
Resistance/ Phase		18.5 Ω 106 Ω
Inductance/ Phase		5.5mH 32mH

Motor Specification

Ø20 mm Can-Stack Linear Actuator	
Power consumption	2.7 W Total
Rotor Inertia	0.5 gcm ²
Insulation Class	Class B
Weight	28g
Insulation Resistance	20MΩ

Special drive considerations may be necessary when leaving shaft fully extended or fully retracted.

Standard motors are Class B rated for maximum temperature of 130°C.

Travel Selection

Linear Travel/ Step	0.0254	0.051	0.102
Step Angle 15°			
Part No (X)	1	2	4



Force vs. Pulse Rate Bipolar. L/R Drive. 100% Duty Cycle

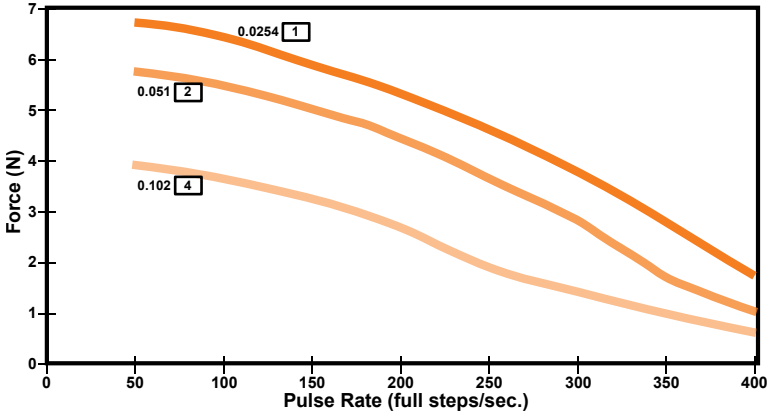

Force vs. Pulse Rate Bipolar. L/R Drive. 25% Duty Cycle

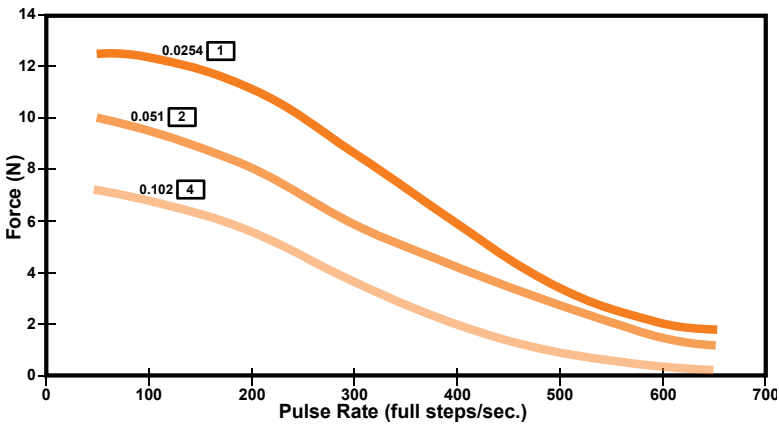

Actuators



Actuators

Force vs. Pulse Rate Bipolar. Chopper. 100% Duty Cycle

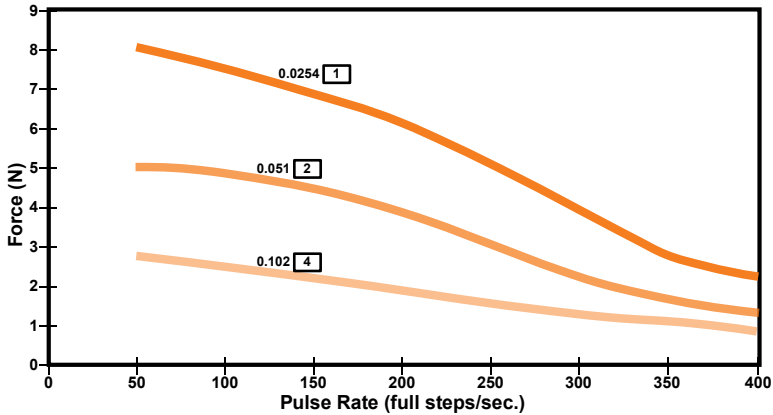

Force vs. Pulse Rate Bipolar. Chopper. 25% Duty Cycle

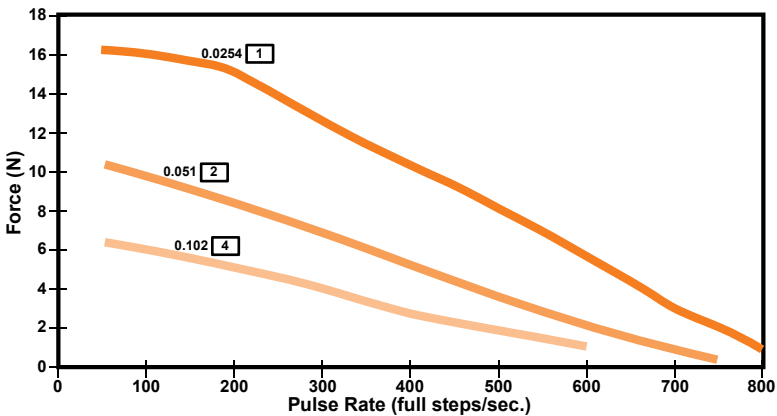

Note: All chopper drive curves were created with a 5 Volt motor and a 40 Volt power supply

Ramping can increase the performance of a motor either by increasing the top speed or getting heavier load accelerated up to speed faster. Also, deceleration can be used to stop the motor without overshoot.



All dimensions in mm

Actuators

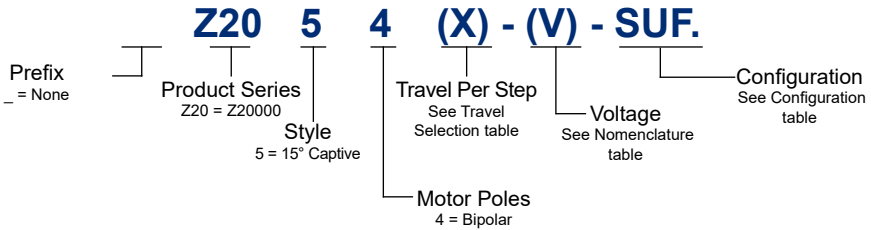
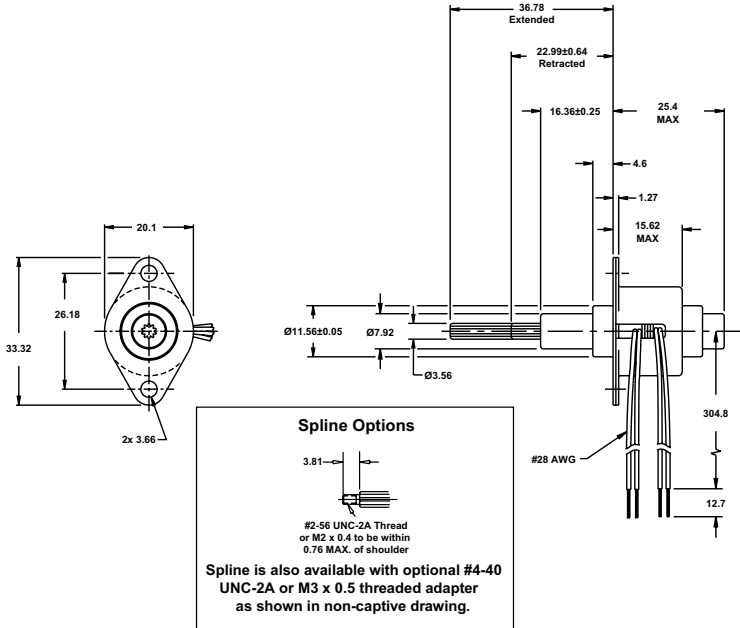

Technical Support

- Selection Guide : Page 1-01
- Product Overview : Page 1-144
- Performance curves : Page 1-192



Nomenclature

Ø20 mm Can-Stack Linear Actuator		
Part No.	Captive (5)	Z2054X-V-SUF
Wiring		Bipolar (4 poles)
Step Angle		15° (5)
Winding Voltage (V)		5 VDC 12 VDC
Current (RMS)/ Phase		250mA 100mA
Resistance/ Phase		20 Ω 1118 Ω
Inductance/ Phase		5.4mH 27mH

Motor Specification

Ø20 mm Can-Stack Linear Actuator	
Power consumption	2.5 W Total
Rotor Inertia	1.13 gcm ²
Insulation Class	Class B
Weight	24.1g
Insulation Resistance	20MΩ

Special drive considerations may be necessary when leaving shaft fully extended or fully retracted.

Standard motors are Class B rated for maximum temperature of 130°C.

Travel Selection

Linear Travel/ Step	0.0254	0.051	0.102
Step Angle 15°			
Part No (X)	1	2	4



Z20000 Series

Ø20 mm Can-Stack Non-captive Shaft

All dimensions in mm

Actuators

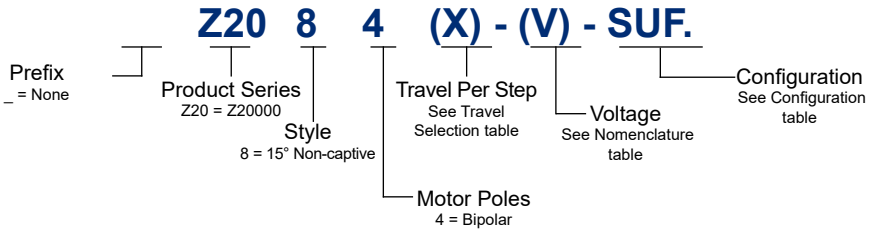
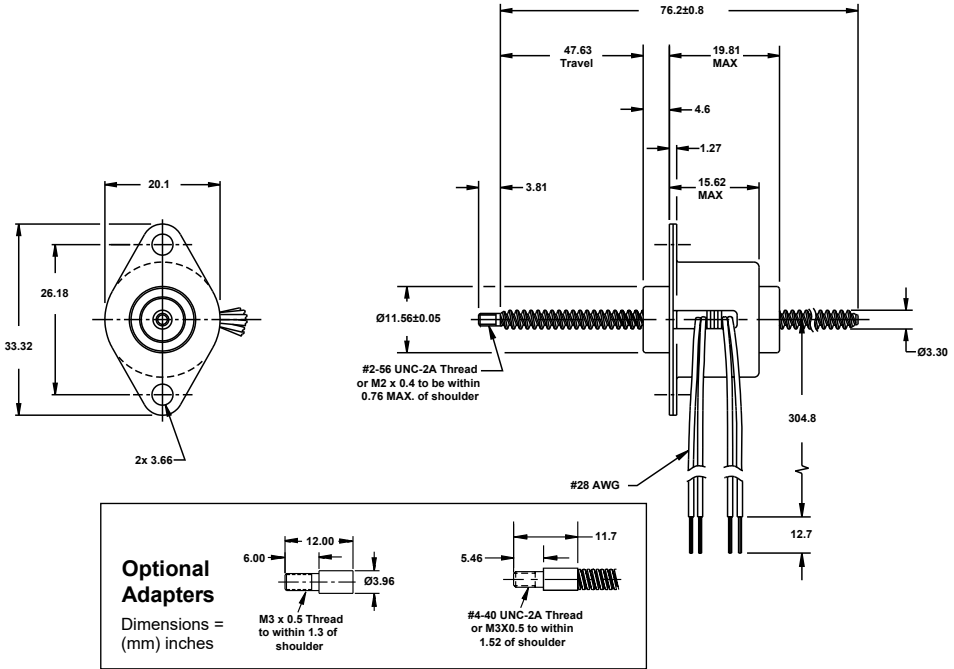

Technical Support

- Selection Guide : Page 1-01
- Product Overview : Page 1-144
- Performance curves : Page 1-192



Nomenclature

Ø20 mm Can-Stack Linear Actuator		
Part No.	Non-captive (8)	Z2084X-V-SUF
Wiring		Bipolar (4 poles)
Step Angle		15° (8)
Winding Voltage (V)		5 VDC 12 VDC
Current (RMS)/ Phase		250mA 100mA
Resistance/ Phase		20 Ω 1118 Ω
Inductance/ Phase		5.4mH 27mH

Motor Specification

Ø20 mm Can-Stack Linear Actuator	
Power consumption	2.5 W Total
Rotor Inertia	1.13 gcm ²
Insulation Class	Class B
Weight	24.1g
Insulation Resistance	20MΩ

Special drive considerations may be necessary when leaving shaft fully extended or fully retracted.

Standard motors are Class B rated for maximum temperature of 130°C.

Travel Selection

Linear Travel/ Step	0.0254	0.051	0.102
Step Angle 15°			
Part No (X)	1	2	4



All dimensions in mm

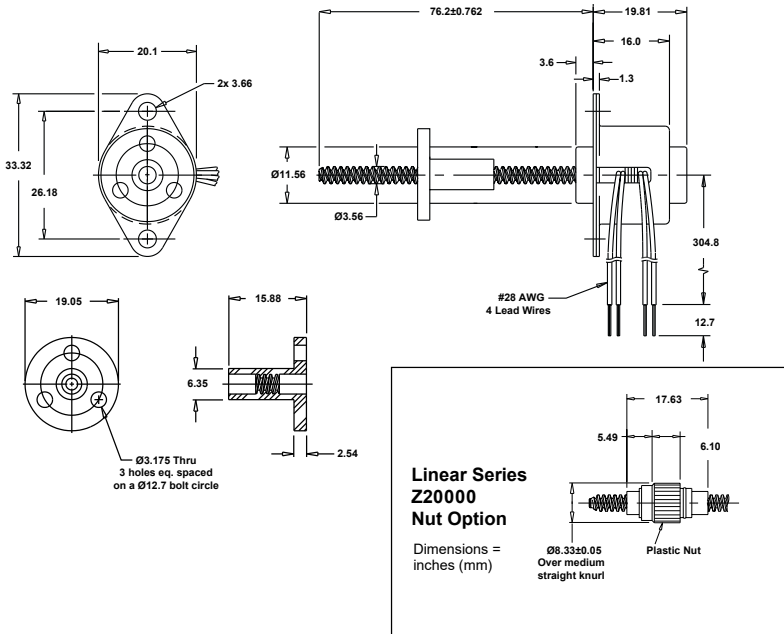

Actuators

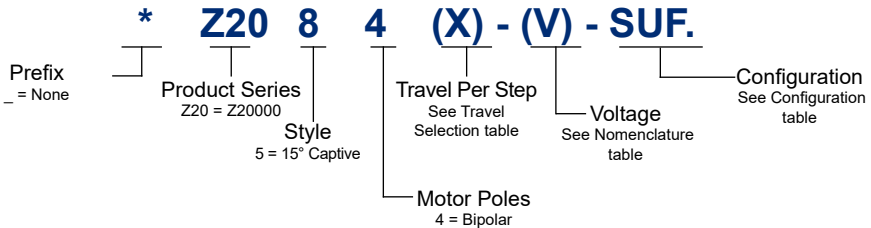

Technical Support

- Selection Guide : Page 1-01
- Product Overview : Page 1-144
- Performance curves : Page 1-192



Nomenclature

Ø20 mm Can-Stack Linear Actuator		
Part No.	External Linear (5)	Z2054X-V-SUF
Wiring		Bipolar (4 poles)
Step Angle		15° (5)
Winding Voltage (V)		5 VDC 12 VDC
Current (RMS)/ Phase		250mA 100mA
Resistance/ Phase		20 Ω 1118 Ω
Inductance/ Phase		5.4mH 27mH

Motor Specification

Ø20 mm Can-Stack Linear Actuator	
Power consumption	2.5 W Total
Rotor Inertia	1.13 gcm ²
Insulation Class	Class B
Weight	24.1g
Insulation Resistance	20MΩ

Special drive considerations may be necessary when leaving shaft fully extended or fully retracted.

Standard motors are Class B rated for maximum temperature of 130°C.

* When ordering Z-Series External Linear motors, add -900 to end of the Part Number.

Travel Selection

Linear Travel/ Step	0.0254	0.051	0.102
Step Angle 15°			
Part No (X)	1	2	4



Force vs. Pulse Rate Bipolar. L/R Drive. 100% Duty Cycle

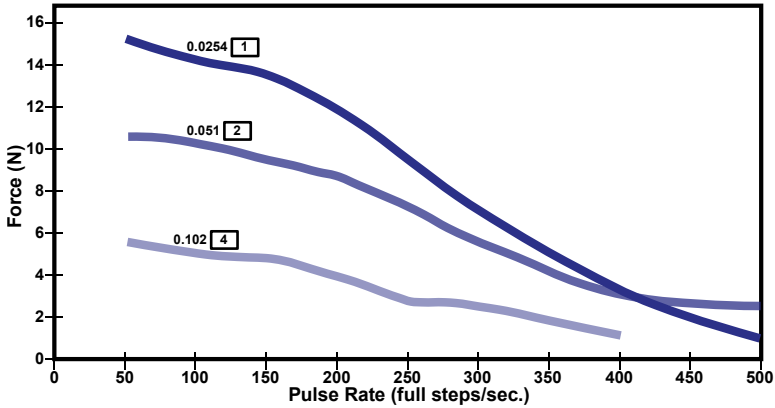

Force vs. Pulse Rate Bipolar. L/R Drive. 25% Duty Cycle

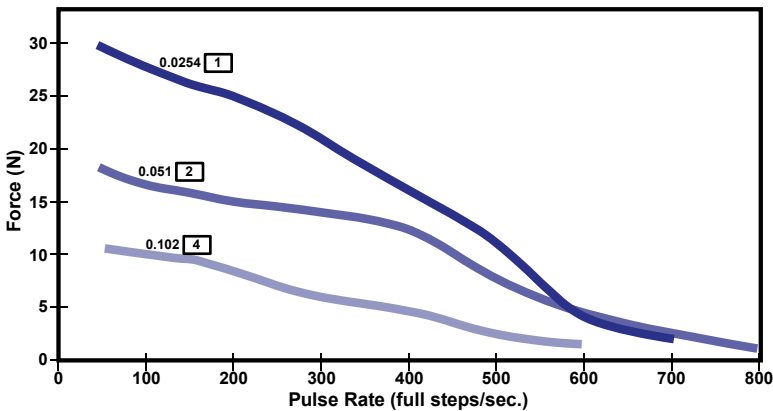

Actuators



Force vs. Pulse Rate Bipolar. Chopper. 100% Duty Cycle

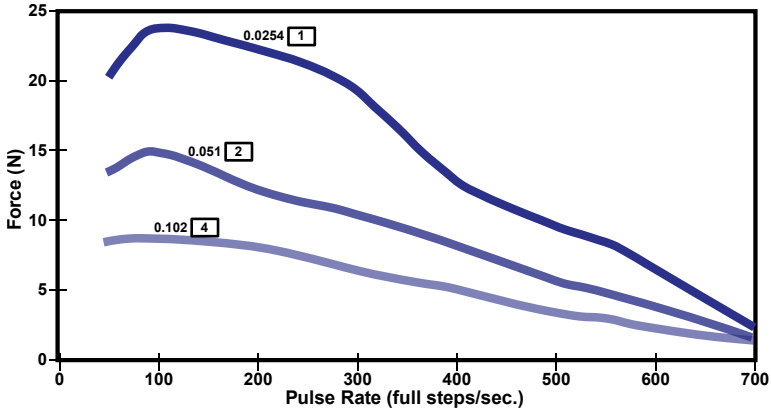

Force vs. Pulse Rate Bipolar. Chopper. 25% Duty Cycle

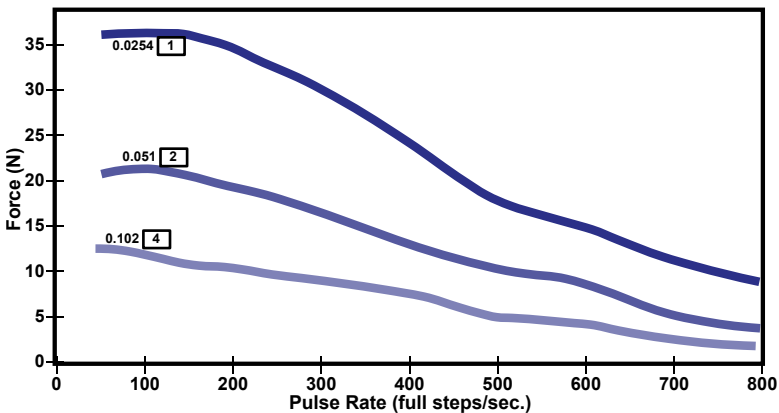

Note: All chopper drive curves were created with a 5 Volt motor and a 40 Volt power supply

Ramping can increase the performance of a motor either by increasing the top speed or getting heavier load accelerated up to speed faster. Also, deceleration can be used to stop the motor without overshoot.



All dimensions in mm

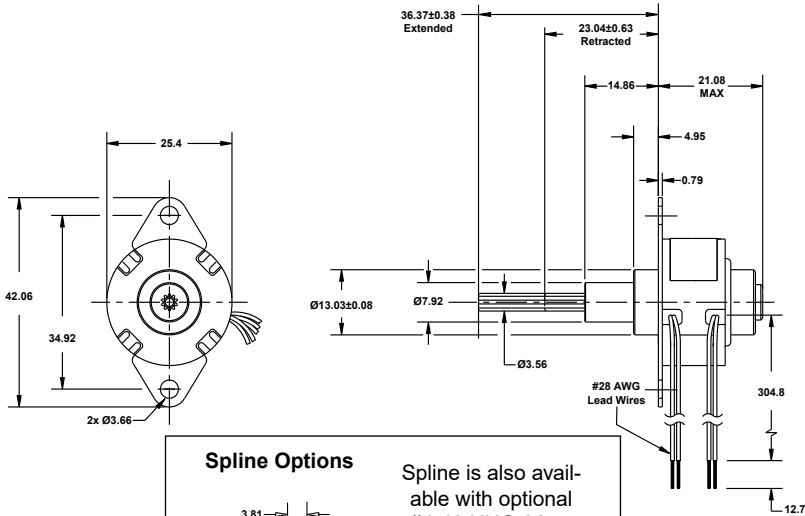

Spline Options

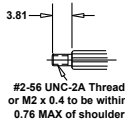

Spline is also available with optional #4-40 UNC-2A or M3 x 0.5 threaded adapter as shown in non-captive drawing.

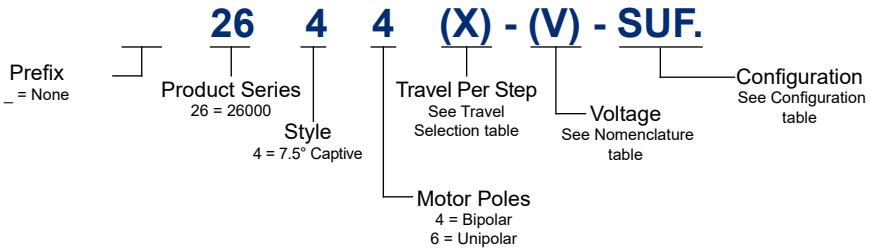

Technical Support

- Selection Guide : Page 1-01
- Product Overview : Page 1-144
- Performance curves : Page 1-200





Nomenclature

Ø26 mm Can-Stack Linear Actuator								
Part No.	Captive (4)	2644X-V-SUF		2654X-V-SUF		2646X-V-SUF		2656X-V-SUF
Wiring		Bipolar (4 poles)				Unipolar* (6 poles)		
Step Angle		7.5° (4)		15° (5)		7.5° (4)		15° (5)
Winding Voltage (V)		5 VDC	12 VDC	5 VDC	12 VDC	5 VDC	12 VDC	5 VDC 12 VDC
Current (RMS)/ Phase		340mA	140mA	340mA	140mA	340mA	140mA	340mA 140mA
Resistance/ Phase		14.7 Ω	84 Ω	14.7 Ω	84 Ω	14.7 Ω	84 Ω	14.7 Ω 84 Ω
Inductance/ Phase		8.5mH	55mH	6.7mH	44mH	4.3mH	24mH	3.4mH 19mH

Motor Specification

Ø26 mm Can-Stack Linear Actuator	
Power consumption	3.4 W Total
Rotor Inertia	1.2 gcm ²
Insulation Class	Class B
Weight	35g
Insulation Resistance	20MΩ

Special drive considerations may be necessary when leaving shaft fully extended or fully retracted.

Standard motors are Class B rated for maximum temperature of 130°C.

Travel Selection

Linear Travel/ Step	0.013	0.0254	0.051
Step Angle 7.5°			
Part No (X)	3	1	2
Linear Travel/Step	0.0254	0.051	0.102
Step Angle 15°			
Part No (X)	1	2	4



26000 Series

Ø26 mm Can-Stack Non-captive Shaft

All dimensions in mm

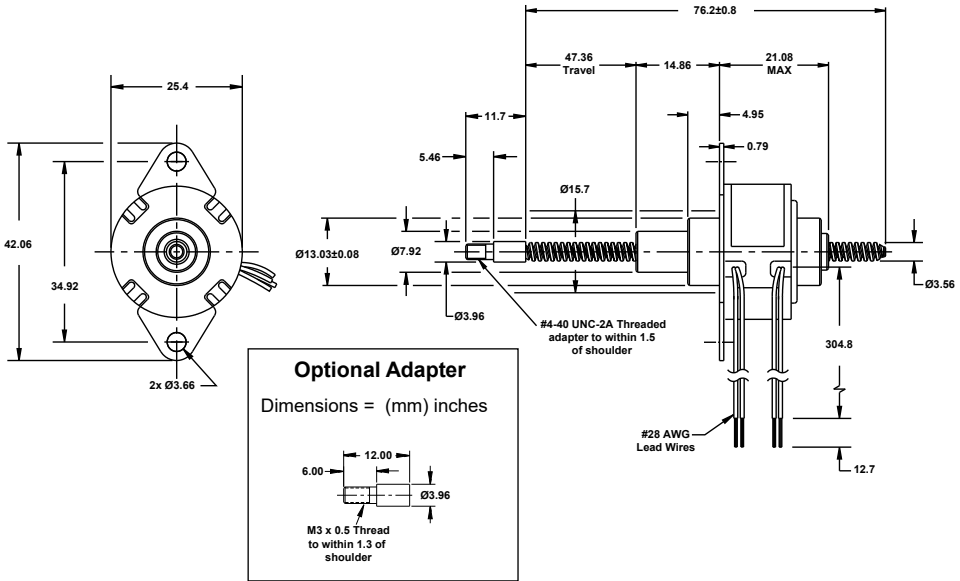

Actuators

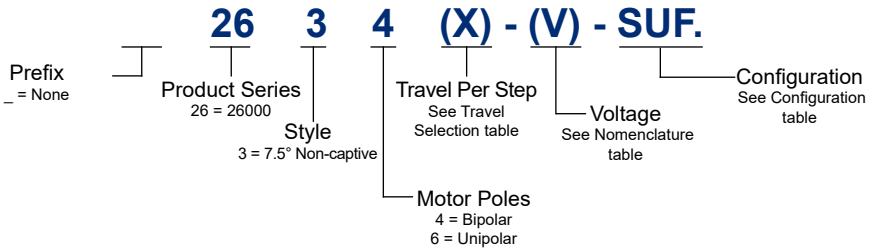

Technical Support

- Selection Guide : Page 1-01
- Product Overview : Page 1-144
- Performance curves : Page 1-200



Nomenclature

Ø26 mm Can-Stack Linear Actuator								
Part No.	Non-captive (3)	2634X-V-SUF		2684X-V-SUF		2636X-V-SUF		2686X-V-SUF
Wiring		Bipolar (4 poles)				Unipolar* (6 poles)		
Step Angle		7.5° (3)		15° (8)		7.5° (3)		15° (5)
Winding Voltage (V)		5 VDC	12 VDC	5 VDC	12 VDC	5 VDC	12 VDC	5 VDC 12 VDC
Current (RMS)/ Phase		340mA	140mA	340mA	140mA	340mA	140mA	340mA 140mA
Resistance/ Phase		14.7 Ω	84 Ω	14.7 Ω	84 Ω	14.7 Ω	84 Ω	14.7 Ω 84 Ω
Inductance/ Phase		8.5mH	55mH	6.7mH	44mH	4.3mH	24mH	3.4mH 19mH

Motor Specification

Ø26 mm Can-Stack Linear Actuator	
Power consumption	3.4 W Total
Rotor Inertia	1.2 gcm ²
Insulation Class	Class B
Weight	35g
Insulation Resistance	20MΩ

Special drive considerations may be necessary when leaving shaft fully extended or fully retracted.

Standard motors are Class B rated for maximum temperature of 130°C.

Travel Selection

Linear Travel/ Step	0.013	0.0254	0.051
Step Angle 7.5°			
Part No (X)	3	1	2
Linear Travel/Step	0.0254	0.051	0.102
Step Angle 15°			
Part No (X)	1	2	4



All dimensions in mm

Actuators

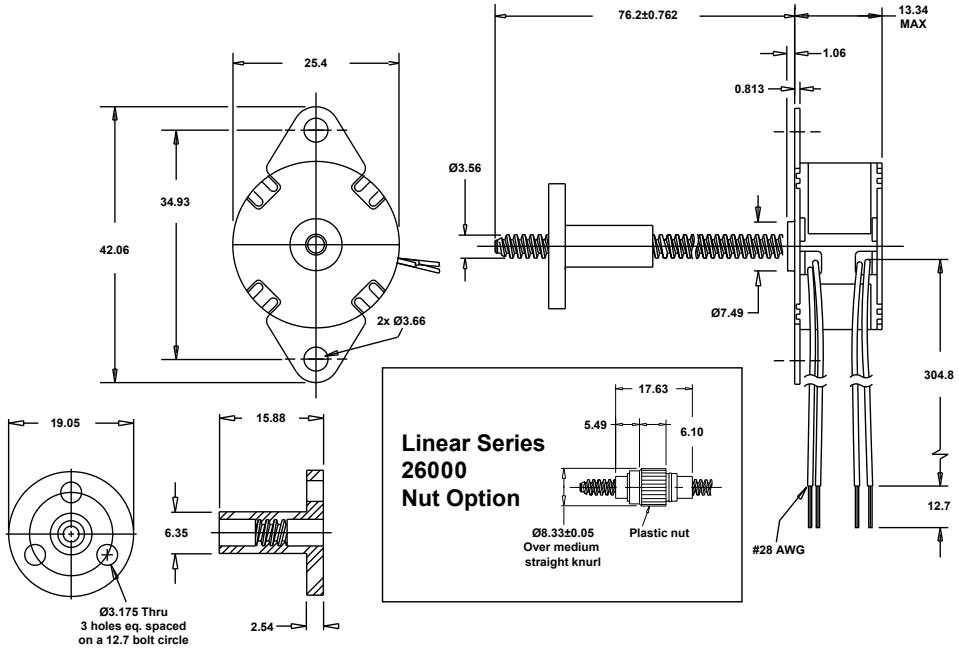

Linear Series 26000 Nut Option

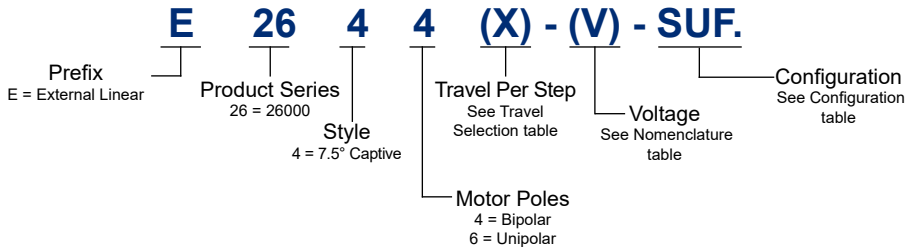
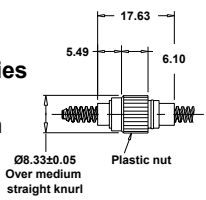

Technical Support

- Selection Guide : Page 1-01
- Product Overview : Page 1-144
- Performance curves : Page 1-200



Nomenclature

Ø26 mm Can-Stack Linear Actuator									
Part No.	External Linear (4)	E2644X-V-SUF		E2654X-V-SUF		E2646X-V-SUF		E2656X-V-SUF	
Wiring		Bipolar (4 poles)				Unipolar* (6 poles)			
Step Angle		7.5° (4)		15° (5)		7.5° (4)		15° (5)	
Winding Voltage (V)		5 VDC	12 VDC	5 VDC	12 VDC	5 VDC	12 VDC	5 VDC	12 VDC
Current (RMS)/ Phase		340mA	140mA	340mA	140mA	340mA	140mA	340mA	140mA
Resistance/ Phase		14.7 Ω	84 Ω	14.7 Ω	84 Ω	14.7 Ω	84 Ω	14.7 Ω	84 Ω
Inductance/ Phase		8.5mH	55mH	6.7mH	44mH	4.3mH	24mH	3.4mH	19mH

Motor Specification

Ø26 mm Can-Stack Linear Actuator	
Power consumption	3.4 W Total
Rotor Inertia	1.2 gcm ²
Insulation Class	Class B
Weight	35g
Insulation Resistance	20MΩ

Special drive considerations may be necessary when leaving shaft fully extended or fully retracted.

Standard motors are Class B rated for maximum temperature of 130°C.

Travel Selection

Linear Travel/ Step	0.013	0.0254	0.051
Step Angle 7.5°			
Part No (X)	3	1	2
Linear Travel/Step	0.0254	0.051	0.102
Step Angle 15°			
Part No (X)	1	2	4



Force vs. Pulse Rate Bipolar. L/R Drive. 100% Duty Cycle

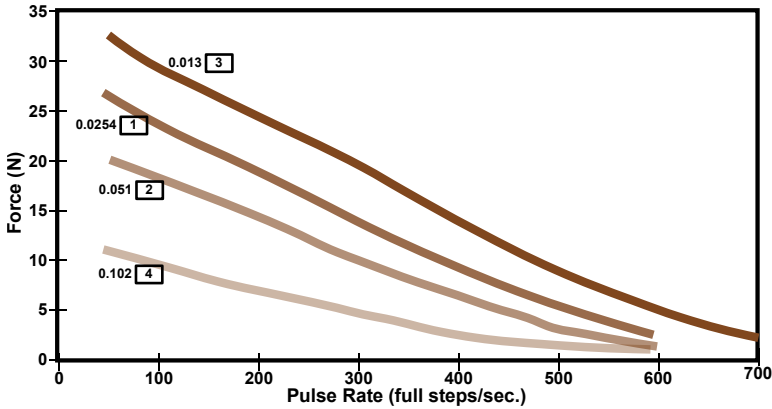

Force vs. Pulse Rate Bipolar. L/R Drive. 25% Duty Cycle

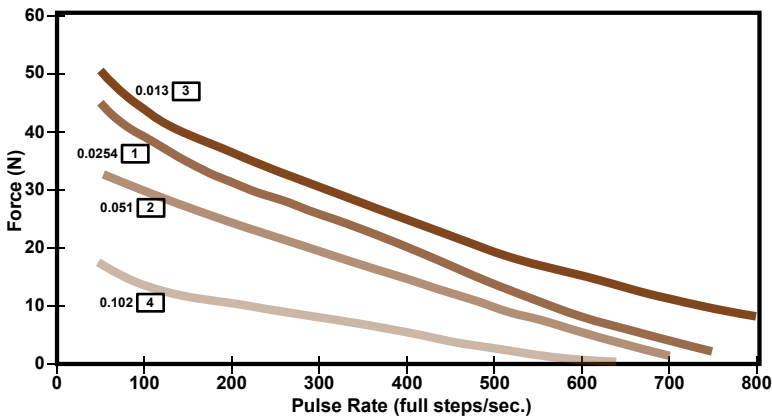

Actuators



Force vs. Pulse Rate Bipolar. Chopper. 100% Duty Cycle

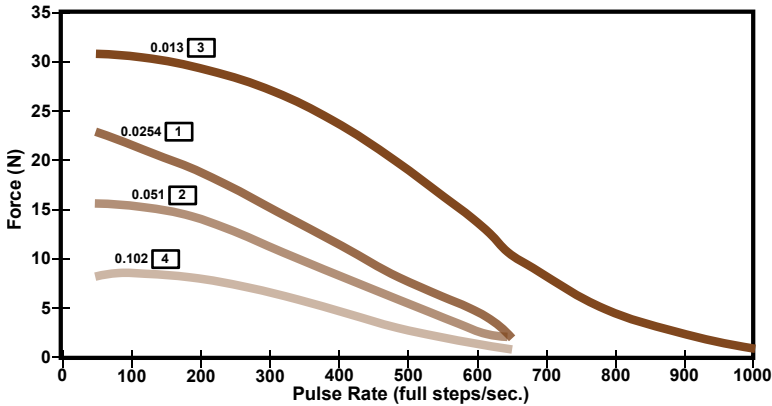

Force vs. Pulse Rate Bipolar. Chopper. 25% Duty Cycle

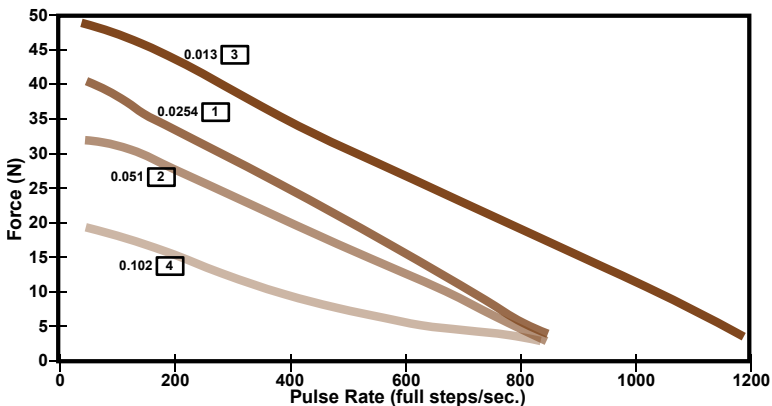

Note: All chopper drive curves were created with a 5 Volt motor and a 40 Volt power supply

Ramping can increase the performance of a motor either by increasing the top speed or getting heavier load accelerated up to speed faster. Also, deceleration can be used to stop the motor without overshoot.

Actuators



**Z26000
Series**

Ø26 mm Can-Stack Captive Shaft

All dimensions in mm

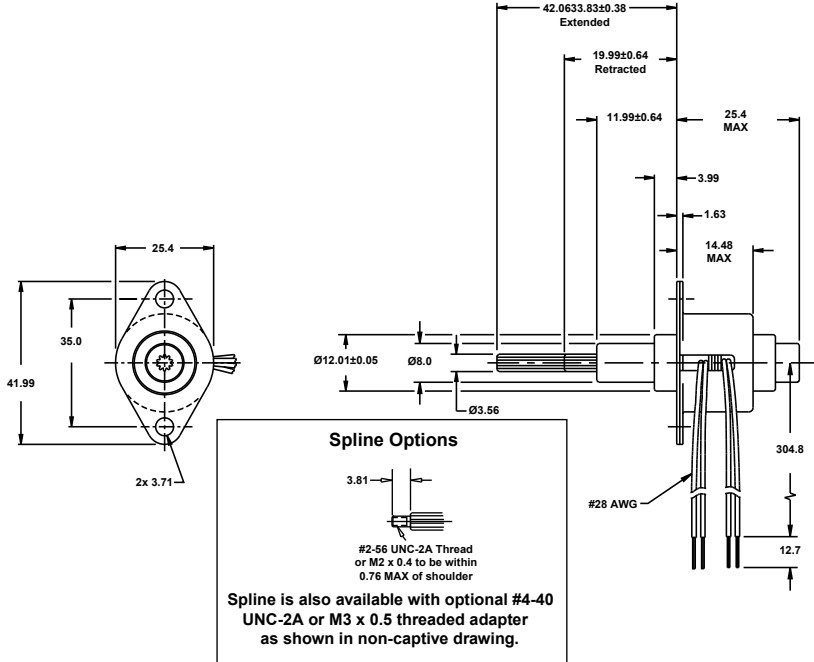

Actuators

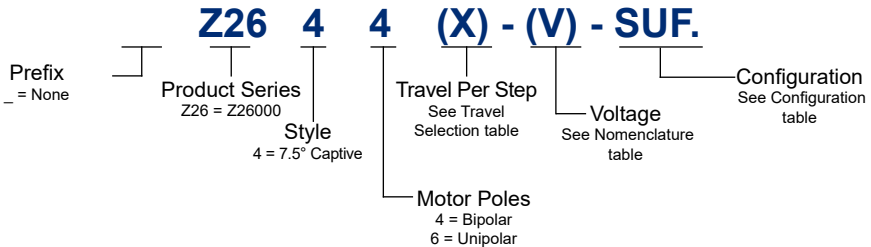

Technical Support

- Selection Guide : Page 1-01
- Product Overview : Page 1-144
- Performance curves : Page 1-210





Nomenclature

Ø26 mm Can-Stack Linear Actuator									
Part No.	Captive (4)	Z2644X-V-SUF		Z2654X-V-SUF		Z2646X-V-SUF		Z2656X-V-SUF	
Wiring		Bipolar (4 poles)				Unipolar* (6 poles)			
Step Angle		7.5° (4)		15° (5)		7.5° (4)		15° (5)	
Winding Voltage (V)		5 VDC	12 VDC	5 VDC	12 VDC	5 VDC	12 VDC	5 VDC	12 VDC
Current (RMS)/ Phase		340mA	140mA	340mA	140mA	340mA	140mA	340mA	140mA
Resistance/ Phase		14.7 Ω	84 Ω	14.7 Ω	84 Ω	14.7 Ω	84 Ω	14.7 Ω	84 Ω
Inductance/ Phase		8.5mH	55mH	6.7mH	44mH	4.3mH	24mH	3.4mH	19mH

Motor Specification

Ø26 mm Can-Stack Linear Actuator	
Power consumption	3.4 W Total
Rotor Inertia	1.4 gcm ²
Insulation Class	Class B
Weight	34g
Insulation Resistance	20MΩ

Special drive considerations may be necessary when leaving shaft fully extended or fully retracted.

Standard motors are Class B rated for maximum temperature of 130°C.

* Unipolar drive gives approximately 40% less thrust vs. bipolar drive.

Travel Selection

Linear Travel/ Step			
Step Angle 7.5°	0.013	0.0254	0.051
Part No (X)	3	1	2
Linear Travel/Step			
Step Angle 15°	0.04166	0.051	0.102
Part No (X)	AS	2	4



All dimensions in mm

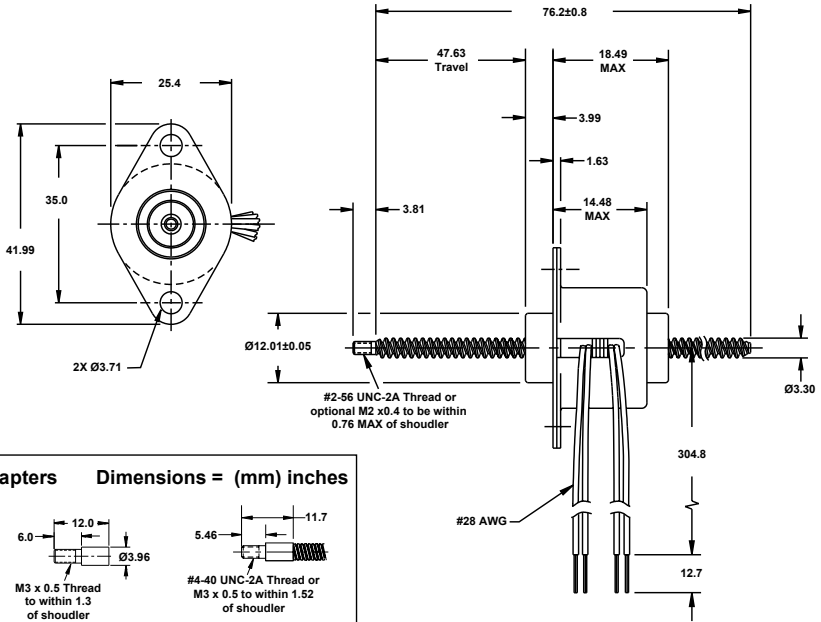

Optional Adapters	Dimensions = (mm) inches
	M3 x 0.5 Thread to within 1.3 of shoulder
	#4-40 UNC-2A Thread or M3 x 0.5 to within 1.52 of shoulder

Actuators

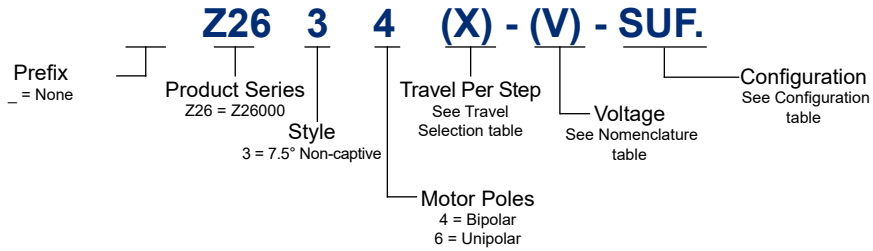

Technical Support

- Selection Guide : Page 1-01
- Product Overview : Page 1-144
- Performance curves : Page 1-210



Nomenclature

Ø26 mm Can-Stack Linear Actuator									
Part No.	Non-captive (3)	Z2634X-V-SUF		Z2684X-V-SUF		Z2636X-V-SUF		Z2686X-V-SUF	
Wiring		Bipolar (4 poles)				Unipolar* (6 poles)			
Step Angle		7.5° (3)		15° (8)		7.5° (3)		15° (8)	
Winding Voltage (V)		5 VDC	12 VDC	5 VDC	12 VDC	5 VDC	12 VDC	5 VDC	12 VDC
Current (RMS)/ Phase		340mA	140mA	340mA	140mA	340mA	140mA	340mA	140mA
Resistance/ Phase		14.7 Ω	84 Ω	14.7 Ω	84 Ω	14.7 Ω	84 Ω	14.7 Ω	84 Ω
Inductance/ Phase		8.5mH	55mH	6.7mH	44mH	4.3mH	24mH	3.4mH	19mH

Motor Specification

Ø26 mm Can-Stack Linear Actuator	
Power consumption	3.4 W Total
Rotor Inertia	1.4 gcm ²
Insulation Class	Class B
Weight	34g
Insulation Resistance	20MΩ

Special drive considerations may be necessary when leaving shaft fully extended or fully retracted.

Standard motors are Class B rated for maximum temperature of 130°C.

* Unipolar drive gives approximately 40% less thrust vs. bipolar drive.

Travel Selection

Linear Travel/ Step			
Step Angle 7.5°	0.013	0.0254	0.051
Part No (X)	3	1	2
Linear Travel/Step			
Step Angle 15°	0.04166	0.051	0.102
Part No (X)	AS	2	4



All dimensions in mm

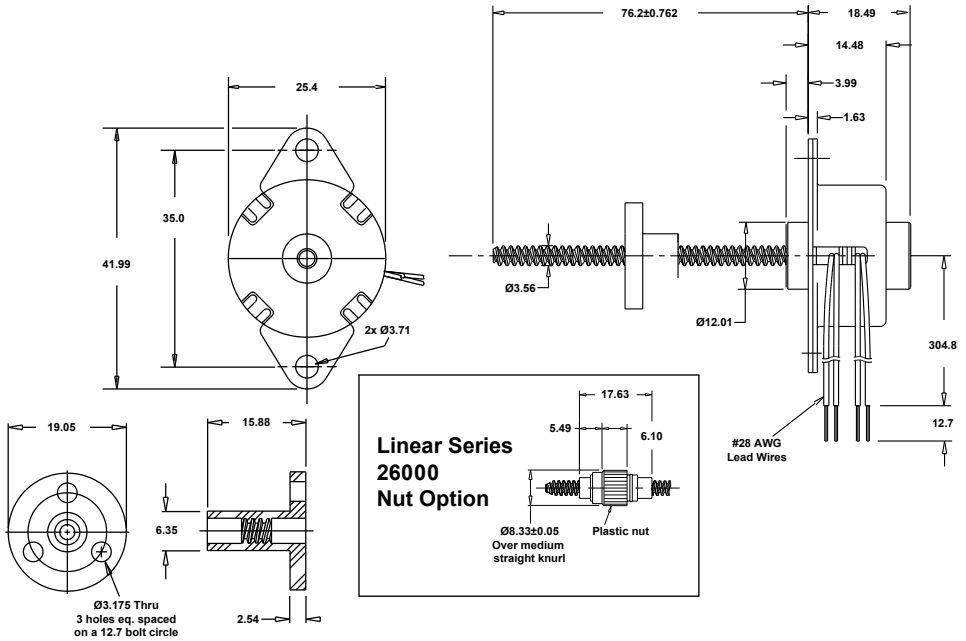

Actuators

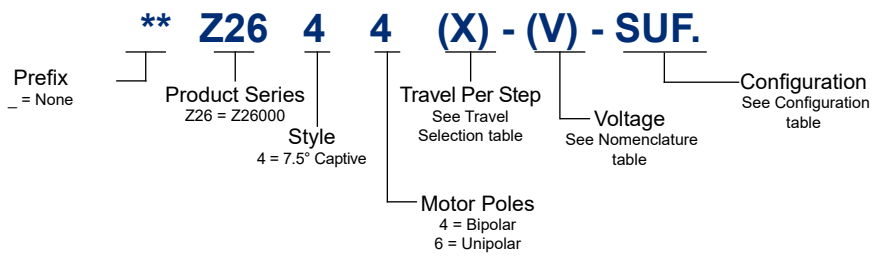

Technical Support

- Selection Guide : Page 1-01
- Product Overview : Page 1-144
- Performance curves : Page 1-210



Nomenclature

Ø26 mm Can-Stack Linear Actuator									
Part No.	External Linear (4)	Z2644X-V-SUF		Z2654X-V-SUF		Z2646X-V-SUF		Z2656X-V-SUF	
Wiring		Bipolar (4 poles)				Unipolar* (6 poles)			
Step Angle		7.5° (4)		15° (5)		7.5° (4)		15° (5)	
Winding Voltage (V)		5 VDC	12 VDC	5 VDC	12 VDC	5 VDC	12 VDC	5 VDC	12 VDC
Current (RMS)/ Phase		340mA	140mA	340mA	140mA	340mA	140mA	340mA	140mA
Resistance/ Phase		14.7 Ω	84 Ω	14.7 Ω	84 Ω	14.7 Ω	84 Ω	14.7 Ω	84 Ω
Inductance/ Phase		8.5mH	55mH	6.7mH	44mH	4.3mH	24mH	3.4mH	19mH

Motor Specification

Ø26 mm Can-Stack Linear Actuator	
Power consumption	3.4 W Total
Rotor Inertia	1.4 gcm ²
Insulation Class	Class B
Weight	34g
Insulation Resistance	20MΩ

Special drive considerations may be necessary when leaving shaft fully extended or fully retracted.

Standard motors are Class B rated for maximum temperature of 130°C.

* Unipolar drive gives approximately 40% less thrust vs. bipolar drive.

Travel Selection

Linear Travel/ Step	0.013	0.0254	0.051
Step Angle 7.5°			
Part No (X)	3	1	2
Linear Travel/Step	0.04166	0.051	0.102
Step Angle 15°			
Part No (X)	AS	2	4



Z26000 Series

Ø26 mm Extended Stroke Can-Stack Captive Shaft

All dimensions in mm

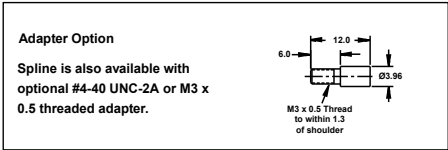
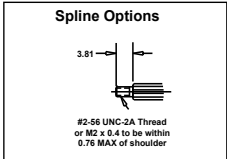
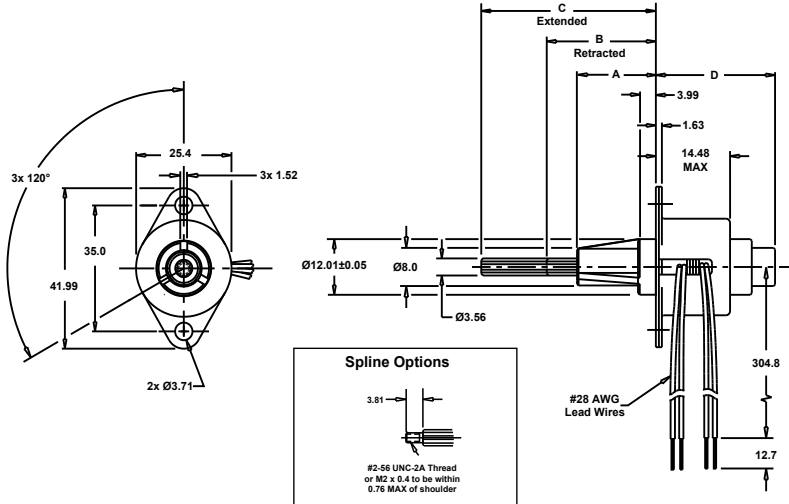

Actuators

Z26 4 4 (X) - (V) - SUF.

Prefix
_ = None

Product Series
Z26 = Z26000

Style
4 = 7.5° Captive

Travel Per Step
See Travel Selection table

Voltage
See Nomenclature table

Configuration
See Configuration table

Motor Poles
4 = Bipolar
6 = Unipolar



Technical Support

- Selection Guide : Page 1-01
- Product Overview : Page 1-144
- Performance curves : Page 1-210



Nomenclature

Ø26 mm Extended Stroke Can-Stack Linear Actuator									
Part No.	Captive (4)	Z2644X-V-SUF	Z2654X-V-SUF	Z2646X-V-SUF	Z2656X-V-SUF				
Wiring		Bipolar (4 poles)			Unipolar* (6 poles)				
Step Angle		7.5° (4)		15° (5)		7.5° (4)		15° (5)	
Winding Voltage (V)		5 VDC	12 VDC	5 VDC	12 VDC	5 VDC	12 VDC	5 VDC	12 VDC
Current (RMS)/ Phase		340mA	140mA	340mA	140mA	340mA	140mA	340mA	140mA
Resistance/ Phase		14.7 Ω	84 Ω	14.7 Ω	84 Ω	14.7 Ω	84 Ω	14.7 Ω	84 Ω
Inductance/ Phase		8.5mH	55mH	6.7mH	44mH	4.3mH	24mH	3.4mH	19mH

Motor Specification

Ø26 mm Can-Stack Linear Actuator	
Power consumption	3.4 W Total
Rotor Inertia	1.4 gcm ²
Insulation Class	Class B
Weight	34g
Insulation Resistance	20MΩ

Special drive considerations may be necessary when leaving shaft fully extended or fully retracted.

Standard motors are Class B rated for maximum temperature of 130°C.

* Unipolar drive gives approximately 40% less thrust vs. bipolar drive.

Travel Selection

Linear Travel/ Step	0.013	0.0254	0.051
Step Angle 7.5°			
Part No (X)	3	1	2
Linear Travel/Step	0.04166	0.051	0.102
Step Angle 15°			
Part No (X)	AS	2	4

Shaft Dimension

Stroke (min)	Front Sleeve A	Retracted B	Extended C	Rear Sleeve D	Suffix Code
18mm	17.25±0.25	25.25±0.64	44.27±0.38	30.7 MAX	-907
25mm	24.26±0.25	32.23±0.64	58.24±0.38	37.6 MAX	-910
31mm	30.25±0.25	38.23±0.64	70.23±0.38	43.7 MAX	-912



Force vs. Pulse Rate Bipolar. L/R Drive. 100% Duty Cycle

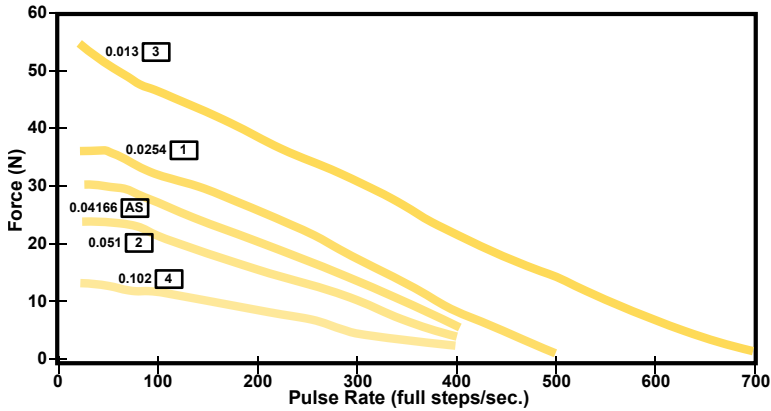

Force vs. Pulse Rate Bipolar. L/R Drive. 25% Duty Cycle

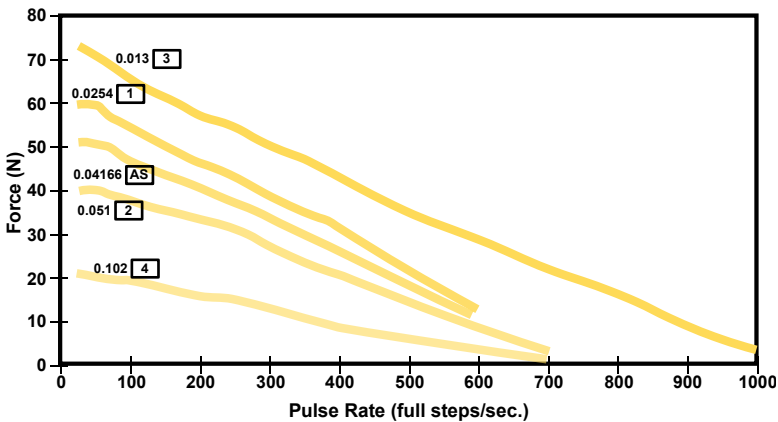

Actuators



Force vs. Pulse Rate Bipolar. Chopper. 100% Duty Cycle

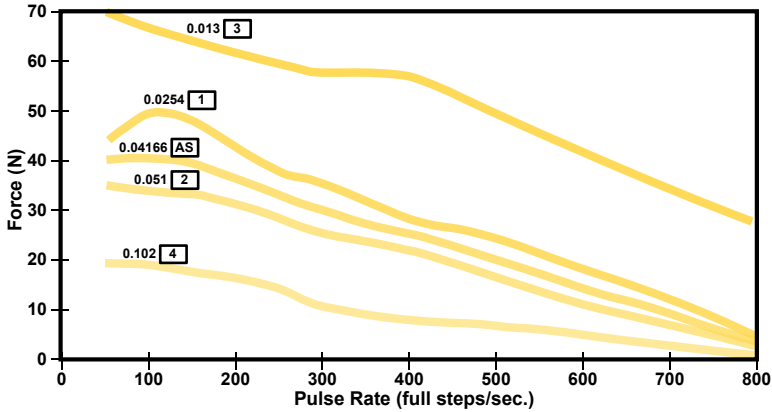

Force vs. Pulse Rate Bipolar. Chopper. 25% Duty Cycle

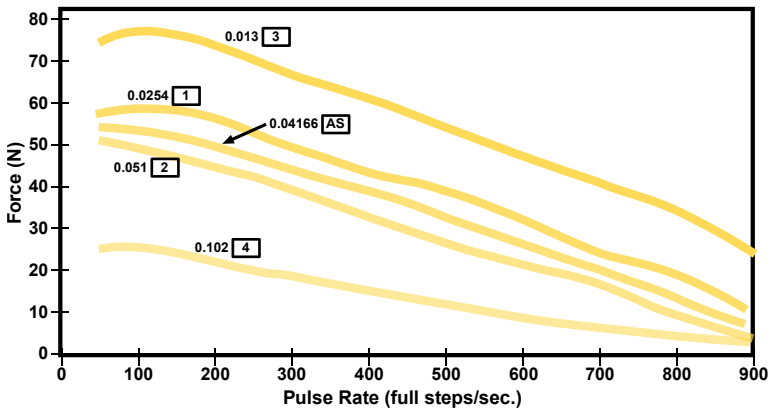

Note: All chopper drive curves were created with a 5 Volt motor and a 40 Volt power supply

Ramping can increase the performance of a motor either by increasing the top speed or getting heavier load accelerated up to speed faster. Also, deceleration can be used to stop the motor without overshoot.

Actuators



26000 Series

Ø26 mm High Resolution Can-Stack Captive Shaft

All dimensions in mm

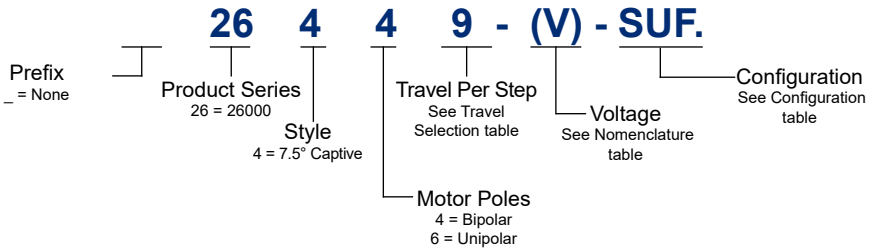
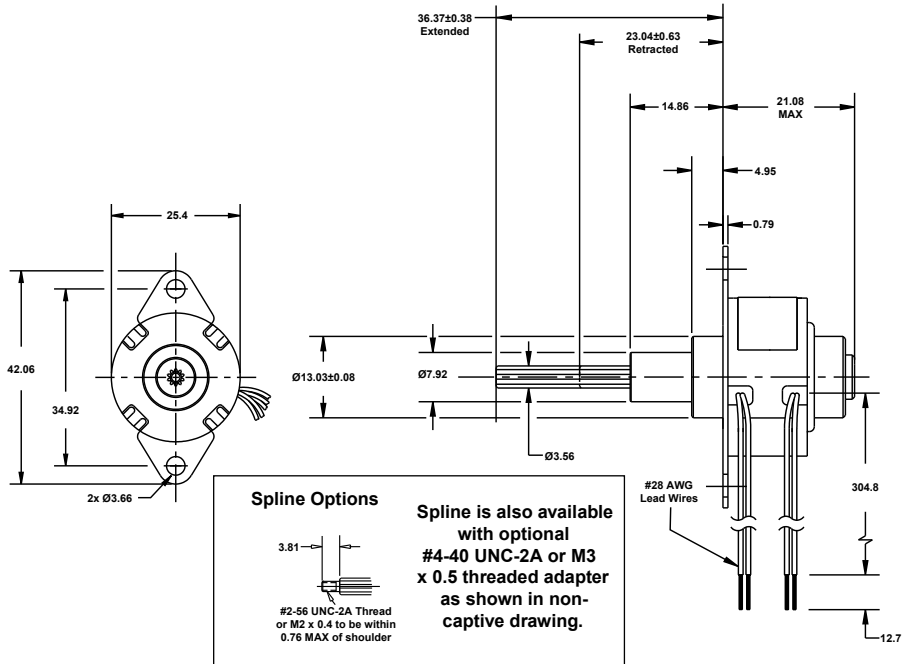

Actuators



Technical Support

- Selection Guide : Page 1-01
- Product Overview : Page 1-144
- Performance curves : Page 1-218



Nomenclature

Ø26 mm High Res Can-Stack Linear Actuator				
Part No.	Captive (4)	26449-V-SUF	26469-V-SUF	
Wiring		Bipolar (4 poles)	Unipolar (6 poles)	
Step Angle		7.5° (4)		
Winding Voltage (V)	5 VDC	12 VDC	5 VDC	12 VDC
Current (RMS)/ Phase	340 mA	140 mA	340 mA	140 mA
Resistance/ Phase	14.7 Ω	84 Ω	14.7 Ω	84 Ω
Inductance/ Phase	8.5 mH	55 mH	4.3 mH	24 mH

Motor Specification

Ø26 mm High Res Can-Stack Linear Actuator	
Power consumption	3.4 W Total
Rotor Inertia	1.2 gcm ²
Insulation Class	Class B
Weight	35g
Insulation Resistance	20MΩ

Special drive considerations may be necessary when leaving shaft fully extended or fully retracted.

Standard motors are Class B rated for maximum temperature of 130°C.

* Unipolar drive gives approximately 30% less thrust vs. bipolar drive.

Travel Selection

Linear Travel/ Step	0.00643
Step Angle 7.5°	
Part No (X)	9



26000 Series

Ø26 mm High Resolution Can-Stack Non-captive Shaft

All dimensions in mm

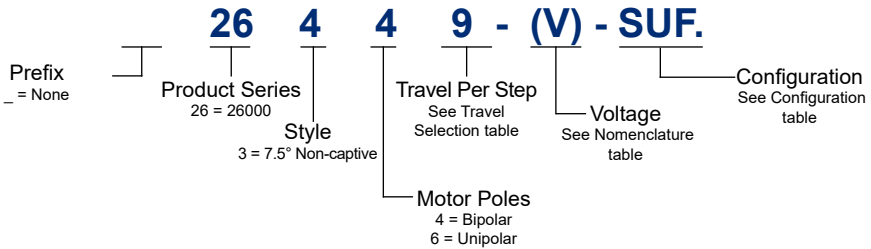
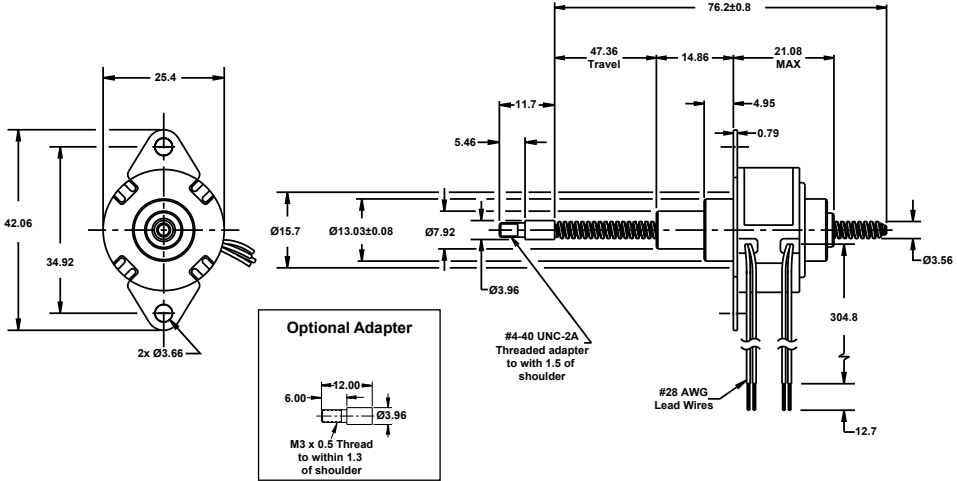

Actuators



Technical Support

- Selection Guide : Page 1-01
- Product Overview : Page 1-144
- Performance curves : Page 1-218



Nomenclature

Ø26 mm High Res Can-Stack Linear Actuator				
Part No.	Non-captive (3)	26349-V-SUF	26369-V-SUF	
Wiring		Bipolar (4 poles)	Unipolar (6 poles)	
Step Angle		7.5° (4)		
Winding Voltage (V)	5 VDC	12 VDC	5 VDC	12 VDC
Current (RMS)/ Phase	340mA	140mA	340mA	140mA
Resistance/ Phase	14.7 Ω	84 Ω	14.7 Ω	84 Ω
Inductance/ Phase	8.5 mH	55 mH	4.3 mH	24 mH

Motor Specification

Ø26 mm High Res Can-Stack Linear Actuator	
Power consumption	3.4 W Total
Rotor Inertia	1.2 gcm ²
Insulation Class	Class B
Weight	35g
Insulation Resistance	20MΩ

Special drive considerations may be necessary when leaving shaft fully extended or fully retracted.

Standard motors are Class B rated for maximum temperature of 130°C.

* Unipolar drive gives approximately 30% less thrust vs. bipolar drive.

Travel Selection

Linear Travel/ Step	0.00643
Step Angle 7.5°	
Part No (X)	9



**26000
Series**

Ø26 mm High Resolution Can-Stack External Linear

All dimensions in mm

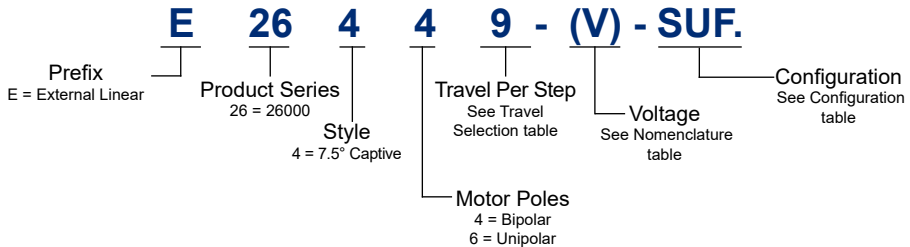
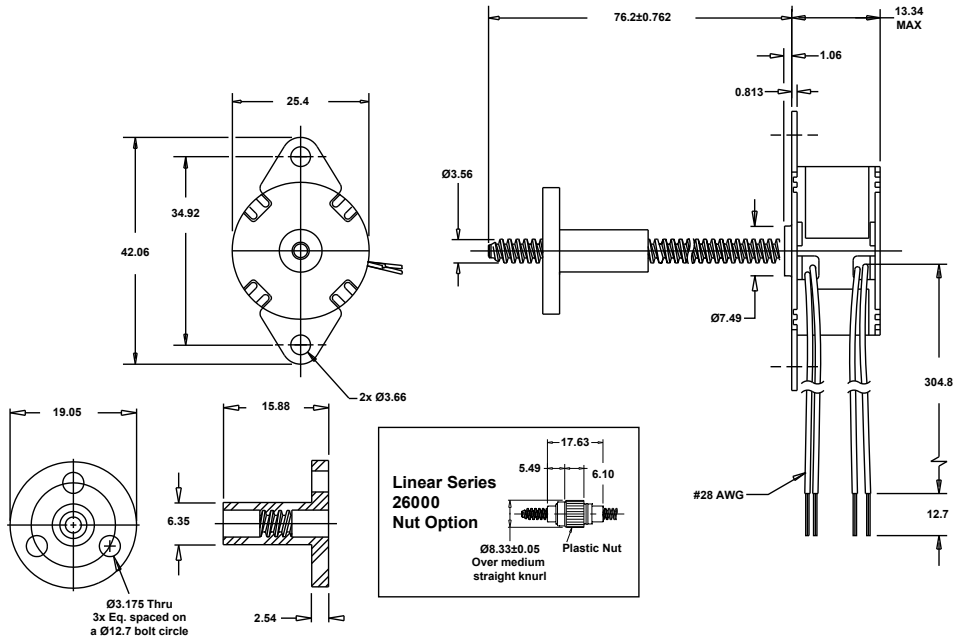

Actuators



Technical Support

- Selection Guide : Page 1-01
- Product Overview : Page 1-144
- Performance curves : Page 1-218



Nomenclature

Ø26 mm High Res Can-Stack Linear Actuator				
Part No.	External Linear (4)	E26449-V-SUF	E26469-V-SUF	
Wiring		Bipolar (4 poles)	Unipolar (6 poles)	
Step Angle		7.5° (4)		
Winding Voltage (V)	5 VDC	12 VDC	5 VDC	12 VDC
Current (RMS)/ Phase	340 mA	140 mA	340 mA	140 mA
Resistance/ Phase	14.7 Ω	84 Ω	14.7 Ω	84 Ω
Inductance/ Phase	8.5 mH	55 mH	4.3 mH	24 mH

Motor Specification

Ø26 mm High Res Can-Stack Linear Actuator	
Power consumption	3.4 W Total
Rotor Inertia	1.2 gcm ²
Insulation Class	Class B
Weight	35g
Insulation Resistance	20MΩ

Special drive considerations may be necessary when leaving shaft fully extended or fully retracted.

Standard motors are Class B rated for maximum temperature of 130°C.

* Unipolar drive gives approximately 30% less thrust vs. bipolar drive.

Travel Selection

Linear Travel/ Step	0.00643
Step Angle 7.5°	
Part No (X)	9



Force vs. Pulse Rate Bipolar. L/R Drive. 100% Duty Cycle

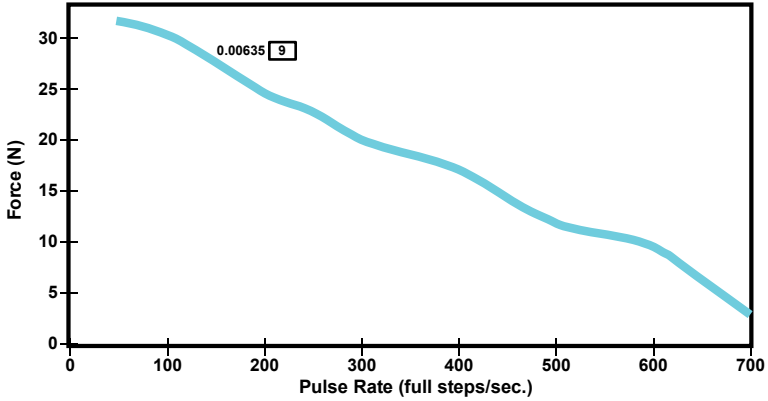

Note: Ramping can increase the performance of a motor either by increasing the top speed or getting heavier load accelerated up to speed faster. Also, deceleration can be used to stop the motor without overshoot.



All dimensions in mm

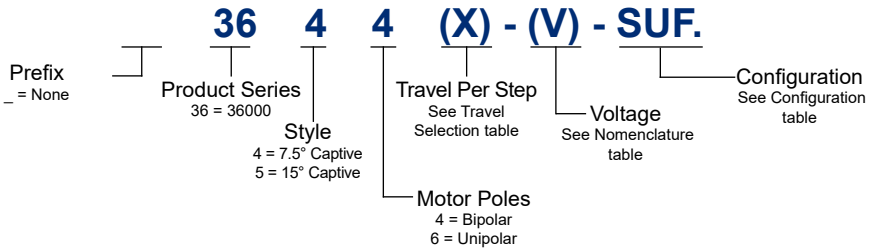
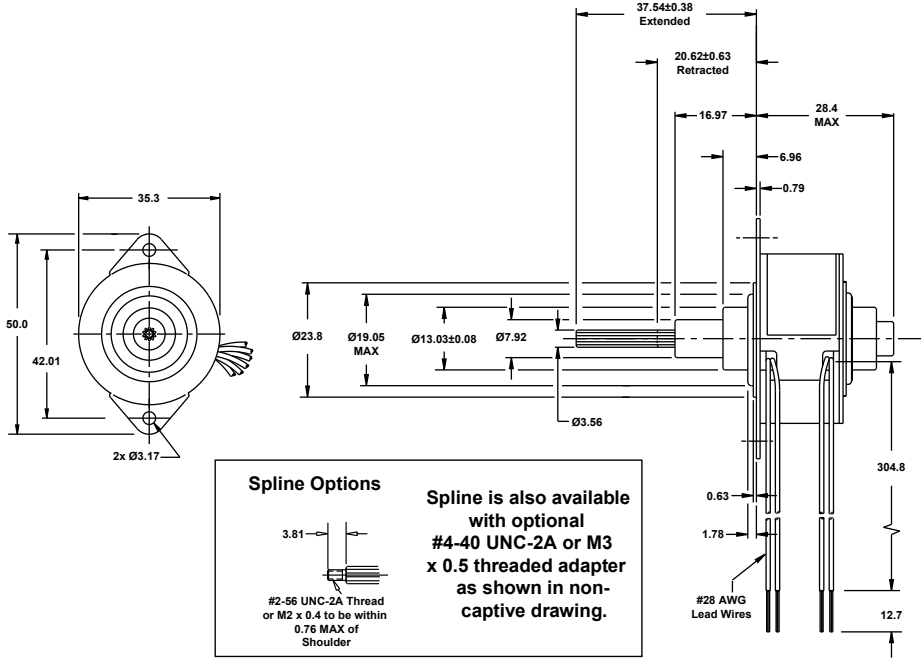

Actuators



Technical Support

- Selection Guide : Page 1-01
- Product Overview : Page 1-144
- Performance curves : Page 1-226



Nomenclature

Ø36 mm Can-Stack Linear Actuator									
Part No.	Captive (4)	3644X-V-SUF		3654X-V-SUF		3646X-V-SUF		3656X-V-SUF	
Wiring		Bipolar (4 poles)				Unipolar* (6 poles)			
Step Angle		7.5° (4)		15° (5)		7.5° (4)		15° (5)	
Winding Voltage (V)		5 VDC	12 VDC	5 VDC	12 VDC	5 VDC	12 VDC	5 VDC	12 VDC
Current (RMS)/ Phase		460mA	190mA	460mA	190mA	460mA	190mA	460mA	190mA
Resistance/ Phase		11 Ω	63 Ω	11 Ω	63 Ω	11 Ω	63 Ω	11 Ω	63 Ω
Inductance/ Phase		7.2mH	45mH	5.5mH	35mH	3.8mH	19mH	3mH	15mH

Motor Specification

Ø36 mm Can-Stack Linear Actuator	
Power consumption	4.6 W Total
Rotor Inertia	10.5 gcm ²
Insulation Class	Class B
Weight	86g
Insulation Resistance	20MΩ

Standard motors are Class B rated for maximum temperature of 130°C.

*Unipolar drive gives approximately 30% less thrust vs. bipolar drive.

Travel Selection

Linear Travel/ Step	0.013	0.0254	0.051
Step Angle 7.5°			
Part No (X)	3	1	2
Linear Travel/Step	0.051	0.102	
Step Angle 15°			
Part No (X)	2	4	



All dimensions in mm

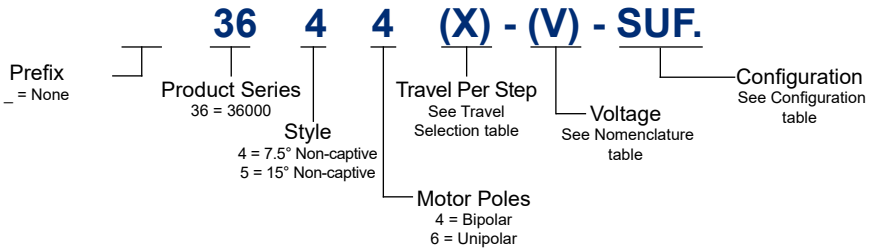
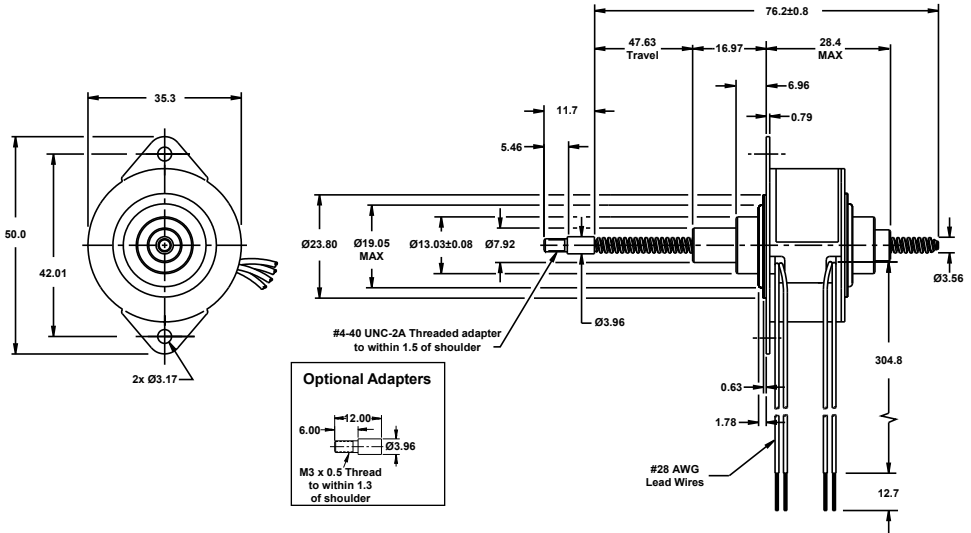

Actuators



Technical Support

- Selection Guide : Page 1-01
- Product Overview : Page 1-144
- Performance curves : Page 1-226



Nomenclature

Ø36 mm Can-Stack Linear Actuator								
Part No.	Non-captive (3)	36344X-V-SUF		3654X-V-SUF		3646X-V-SUF		3656X-V-SUF
Wiring		Bipolar (4 poles)				Unipolar* (6 poles)		
Step Angle		7.5° (3)		15° (8)		7.5° (3)		15° (8)
Winding Voltage (V)		5 VDC	12 VDC	5 VDC	12 VDC	5 VDC	12 VDC	5 VDC
Current (RMS)/ Phase		460mA	190mA	460mA	190mA	460mA	190mA	460mA
Resistance/ Phase		11 Ω	63 Ω	11 Ω	63 Ω	11 Ω	63 Ω	63 Ω
Inductance/ Phase		7.2mH	45mH	5.5mH	35mH	3.8mH	19mH	3mH

Motor Specification

Ø36 mm Can-Stack Linear Actuator	
Power consumption	4.6 W Total
Rotor Inertia	10.5 gcm ²
Insulation Class	Class B
Weight	86g
Insulation Resistance	20MΩ

Standard motors are Class B rated for maximum temperature of 130°C.

*Unipolar drive gives approximately 30% less thrust vs. bipolar drive.

Travel Selection

Linear Travel/ Step	0.013	0.0254	0.051
Step Angle 7.5°			
Part No (X)	3	1	2
Linear Travel/Step	0.051	0.102	
Step Angle 15°			
Part No (X)	2	4	



36000 Series

Ø36 mm Can-Stack External Linear

All dimensions in mm

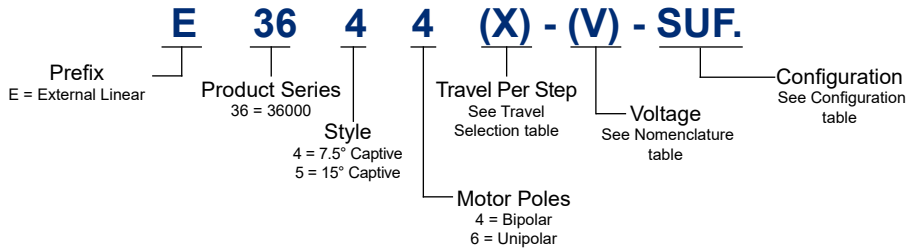
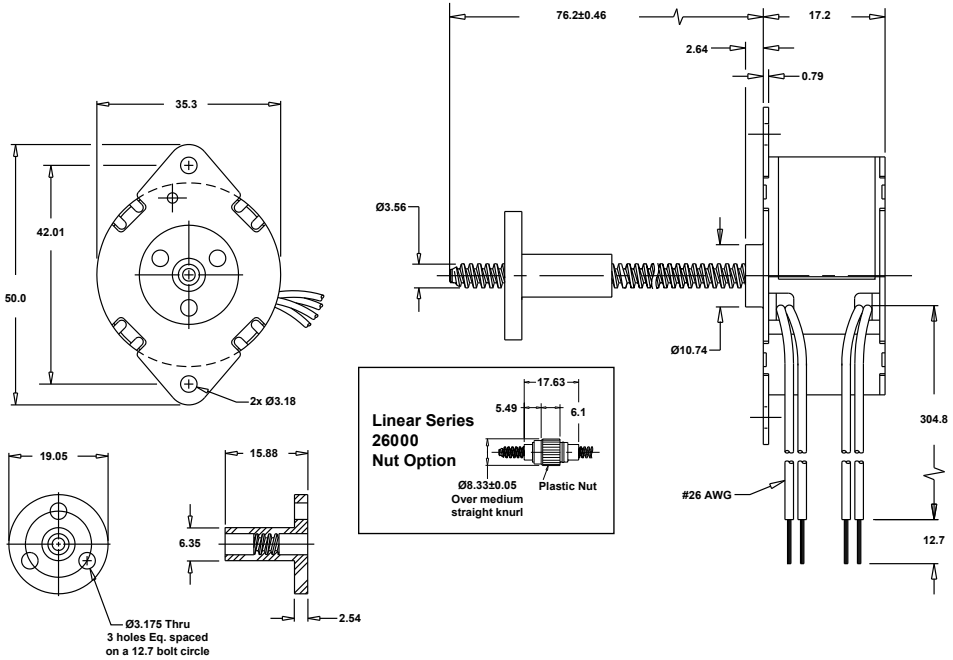

Actuators



Technical Support

- Selection Guide : Page 1-01
- Product Overview : Page 1-144
- Performance curves : Page 1-226



Nomenclature

Ø36 mm Can-Stack Linear Actuator									
Part No.	External Linear (4)	E3644X-V-SUF		E3654X-V-SUF		E3646X-V-SUF		E3656X-V-SUF	
Wiring		Bipolar (4 poles)				Unipolar* (6 poles)			
Step Angle		7.5° (4)		15° (5)		7.5° (4)		15° (5)	
Winding Voltage (V)		5 VDC	12 VDC	5 VDC	12 VDC	5 VDC	12 VDC	5 VDC	12 VDC
Current (RMS)/ Phase		460mA	190mA	460mA	190mA	460mA	190mA	460mA	190mA
Resistance/ Phase		11 Ω	63 Ω	11 Ω	63 Ω	11 Ω	63 Ω	11 Ω	63 Ω
Inductance/ Phase		7.2mH	45mH	5.5mH	35mH	3.8mH	19mH	3mH	15mH

Motor Specification

Ø36 mm Can-Stack Linear Actuator	
Power consumption	4.6 W Total
Rotor Inertia	10.5 gcm ²
Insulation Class	Class B
Weight	86g
Insulation Resistance	20MΩ

Standard motors are Class B rated for maximum temperature of 130°C.

*Unipolar drive gives approximately 30% less thrust vs. bipolar drive.

Travel Selection

Linear Travel/ Step	0.013	0.0254	0.051
Step Angle 7.5°			
Part No (X)	3	1	2
Linear Travel/Step	0.051	0.102	
Step Angle 15°			
Part No (X)	2	4	



Force vs. Pulse Rate Bipolar. L/R Drive. 100% Duty Cycle

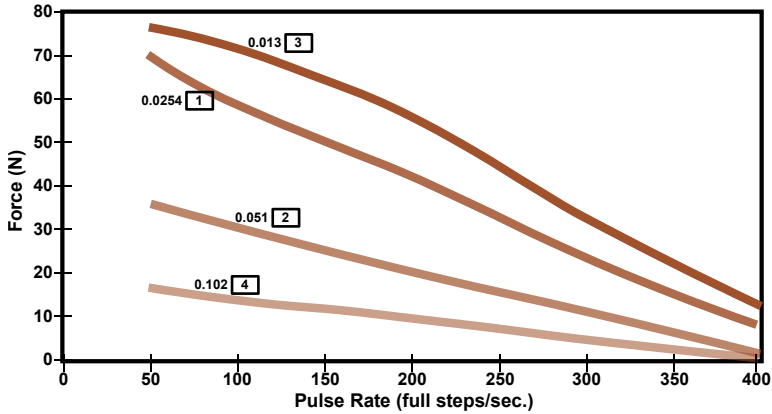

Force vs. Pulse Rate Bipolar. L/R Drive. 25% Duty Cycle

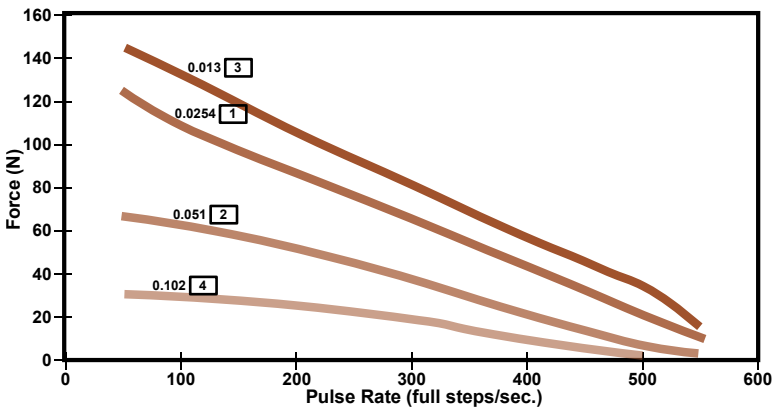

Actuators



Force vs. Pulse Rate Bipolar. Chopper. 100% Duty Cycle

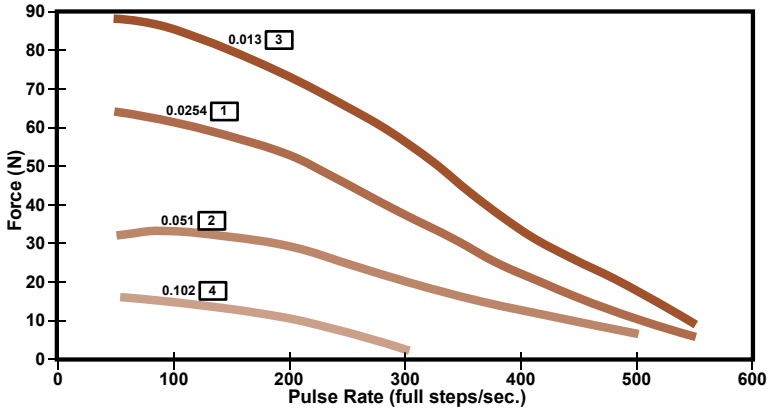

Force vs. Pulse Rate Bipolar. Chopper. 25% Duty Cycle

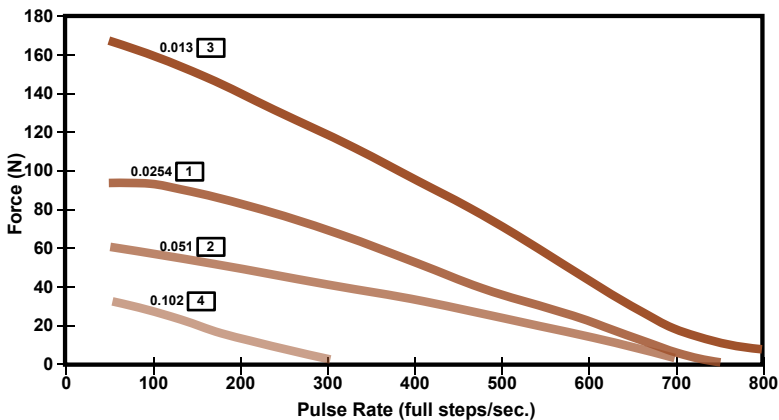

Note: All chopper drive curves were created with a 5 Volt motor and a 40 Volt power supply

Ramping can increase the performance of a motor either by increasing the top speed or getting heavier load accelerated up to speed faster. Also, deceleration can be used to stop the motor without overshoot.

Actuators



36000 Series

Ø36 mm High Resolution Can-Stack Captive Shaft

All dimensions in mm

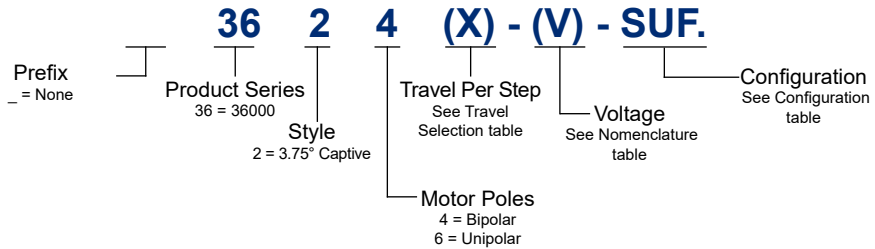
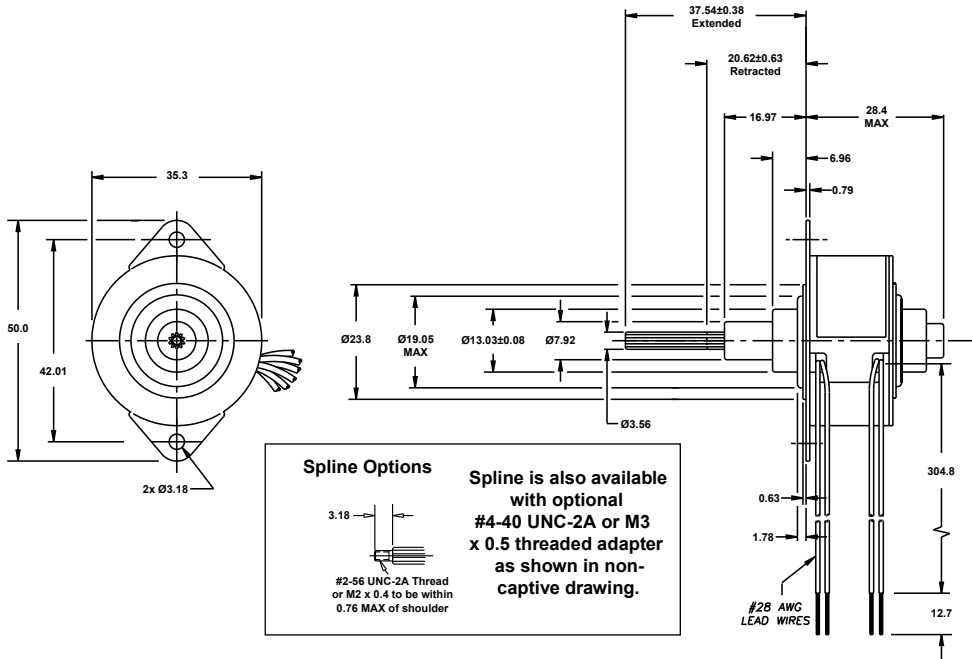

Technical Support

- Selection Guide : Page 1-01
- Product Overview : Page 1-144
- Performance curves : Page 1-234



Actuators



Nomenclature

Ø36 mm High Res Can-Stack Linear Actuator				
Part No.	Captive (2)	3624X-V-SUF	3624X-V-SUF	
Wiring		Bipolar (4 poles)	Unipolar (6 poles)	
Step Angle		3.75°		
Winding Voltage (V)	5 VDC	12 VDC	5 VDC	12 VDC
Current (RMS)/ Phase	460 mA	190 mA	460 mA	190 mA
Resistance/ Phase	11 Ω	63 Ω	11 Ω	63 Ω
Inductance/ Phase	9.2 mH	53 mH	4.6 mH	26 mH

Motor Specification

Ø36 mm High Res Can-Stack Linear Actuator	
Power consumption	4.6 W Total
Rotor Inertia	10.5 gcm ²
Insulation Class	Class B
Weight	86g
Insulation Resistance	20MΩ

Standard motors are Class B rated for maximum temperature of 130°C.

*Unipolar drive gives approximately 30% less thrust vs. bipolar drive.

Travel Selection

Linear Travel/ Step	0.0032	0.0064
Step Angle 3.75°		
Part No (X)	7	9



36000 Series

Ø36 mm High Resolution Can-Stack Non-captive Shaft

All dimensions in mm

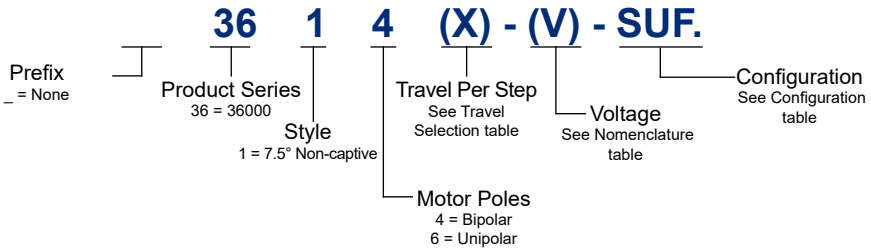
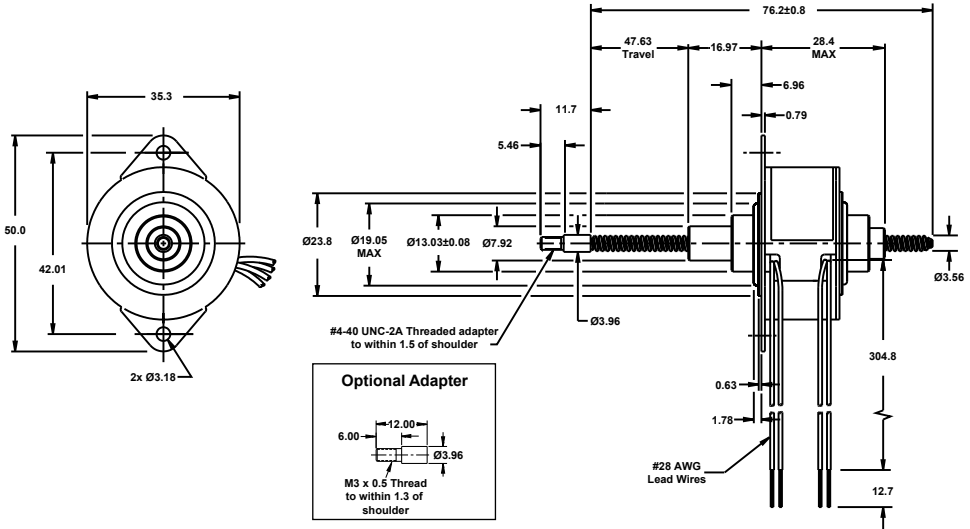

Technical Support

- Selection Guide : Page 1-01
- Product Overview : Page 1-144
- Performance curves : Page 1-234

Actuators



Nomenclature

Ø36 mm High Res Can-Stack Linear Actuator				
Part No.	Non-captive (1)	3614X-V-SUF	3616X-V-SUF	
Wiring		Bipolar (4 poles)	Unipolar (6 poles)	
Step Angle		3.75°		
Winding Voltage (V)	5 VDC	12 VDC	5 VDC	12 VDC
Current (RMS)/ Phase	460 mA	190 mA	460 mA	190 mA
Resistance/ Phase	11 Ω	63 Ω	11 Ω	63 Ω
Inductance/ Phase	9.2 mH	53 mH	4.6 mH	26 mH

Motor Specification

Ø36 mm High Res Can-Stack Linear Actuator	
Power consumption	4.6 W Total
Rotor Inertia	10.5 gcm ²
Insulation Class	Class B
Weight	86g
Insulation Resistance	20MΩ

Standard motors are Class B rated for maximum temperature of 130°C.

*Unipolar drive gives approximately 30% less thrust vs. bipolar drive.

Travel Selection

Linear Travel/ Step	0.0032	0.0064
Step Angle 3.75°		
Part No (X)	7	9



36000 Series

Ø36 mm High Resolution Can-Stack External Linear

All dimensions in mm

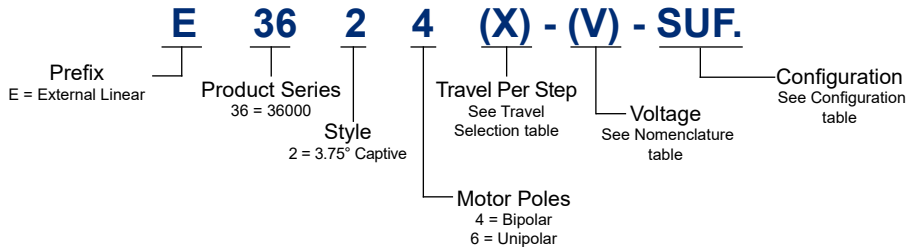
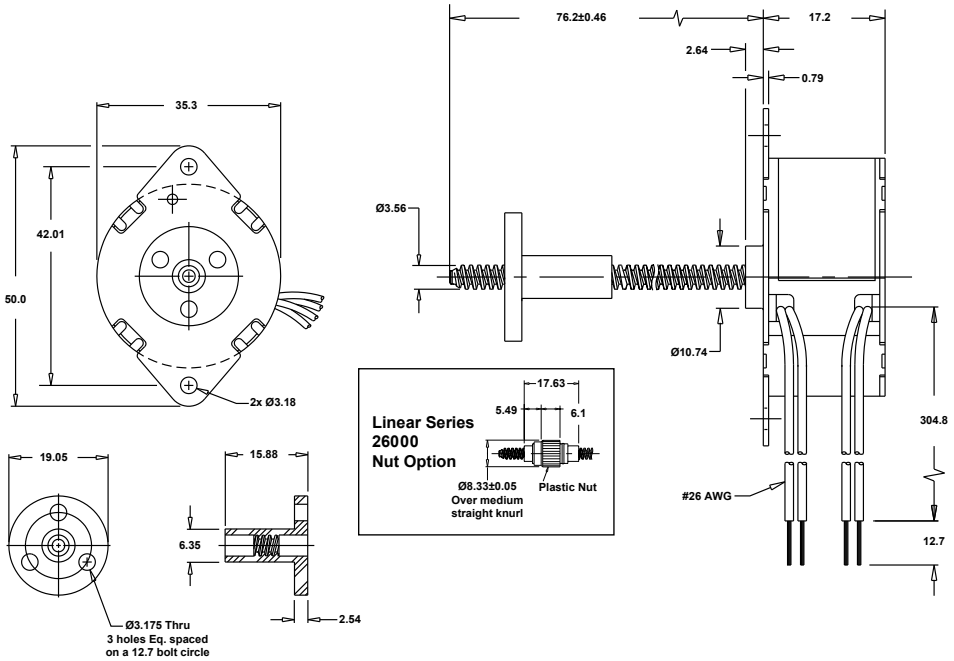

Technical Support

- Selection Guide : Page 1-01
- Product Overview : Page 1-144
- Performance curves : Page 1-234



Actuators



Nomenclature

Ø36 mm High Res Can-Stack Linear Actuator					
Part No.	External Linear (2)	E3624X-V-SUF	E3626X-V-SUF		
Wiring		Bipolar (4 poles)	Unipolar (6 poles)		
Step Angle		3.75°			
Winding Voltage (V)		5 VDC	12 VDC	5 VDC	12 VDC
Current (RMS)/ Phase		460 mA	190 mA	460 mA	190 mA
Resistance/ Phase		11 Ω	63 Ω	11 Ω	63 Ω
Inductance/ Phase		9.2 mH	53 mH	4.6 mH	26 mH

Motor Specification

Ø36 mm High Res Can-Stack Linear Actuator	
Power consumption	4.6 W Total
Rotor Inertia	10.5 gcm ²
Insulation Class	Class B
Weight	86g
Insulation Resistance	20MΩ

Standard motors are Class B rated for maximum temperature of 130°C.

*Unipolar drive gives approximately 30% less thrust vs. bipolar drive.

Travel Selection

Linear Travel/ Step	0.0032	0.0064
Step Angle 3.75°		
Part No (X)	7	9



Force vs. Pulse Rate Bipolar. L/R Drive. 100% Duty Cycle

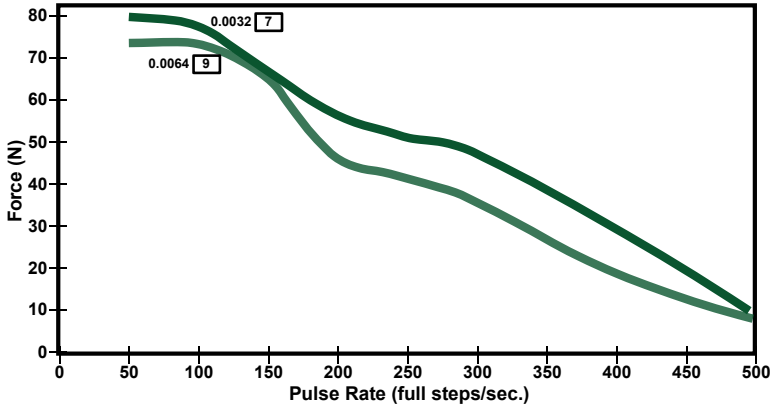

Note: All chopper drive curves were created with a 5 Volt motor and a 40 Volt power supply

Ramping can increase the performance of a motor either by increasing the top speed or getting heavier load accelerated up to speed faster. Also, deceleration can be used to stop the motor without overshoot.



46000 Series

Ø46 mm Can-Stack Captive Shaft

All dimensions in mm

Actuators

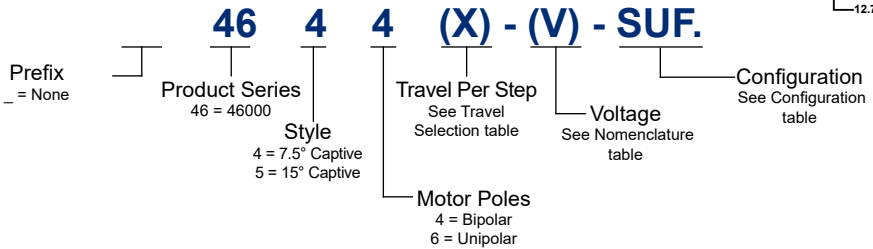
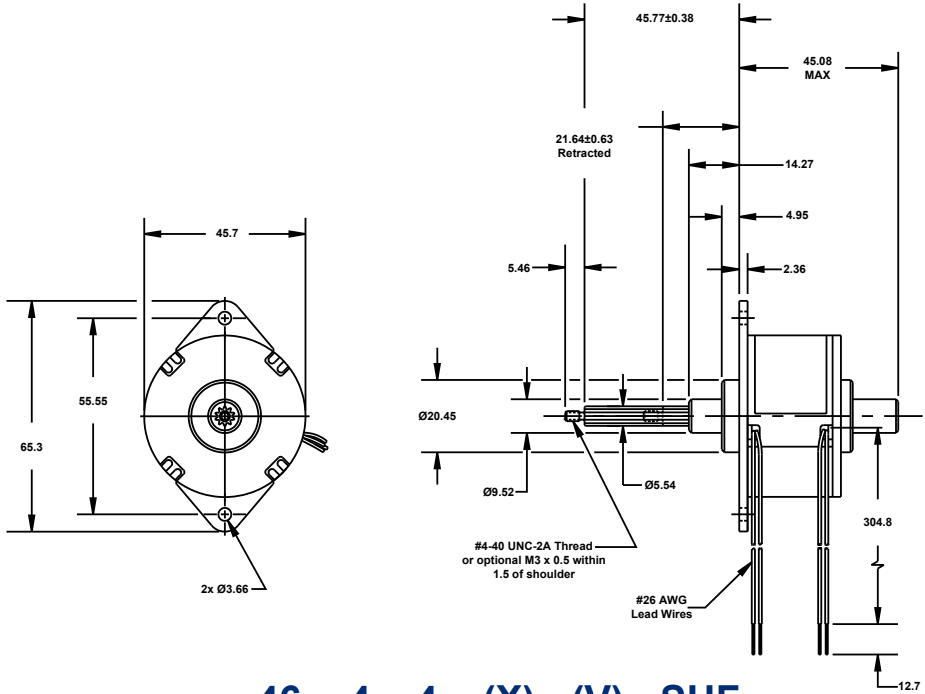

Technical Support

- Selection Guide : Page 1-01
- Product Overview : Page 1-144
- Performance curves : Page 1-244



Nomenclature

Ø46 mm Can-Stack Linear Actuator									
Part No.	Captive (4)	4644X-V-SUF		4654X-V-SUF		4646X-V-SUF		4656X-V-SUF	
Wiring		Bipolar (4 poles)				Unipolar* (6 poles)			
Step Angle		7.5° (4)		15° (5)		7.5° (4)		15° (5)	
Winding Voltage (V)		5 VDC	12 VDC	5 VDC	12 VDC	5 VDC	12 VDC	5 VDC	12 VDC
Current (RMS)/ Phase		1.0A	0.41A	1.0 A	0.41A	1.0A	0.41A	1.0 A	0.41A
Resistance/ Phase		5 Ω	29 Ω	51 Ω	29 Ω	5 Ω	29 Ω	51 Ω	29 Ω
Inductance/ Phase		9 mH	52mH	7.1 mH	39mH	4.5 mH	26 mH	3.5 mH	20 mH

Motor Specification

Ø46 mm Can-Stack Linear Actuator	
Power consumption	10 W Total
Rotor Inertia	25 gcm ²
Insulation Class	Class B
Weight	255g
Insulation Resistance	20MΩ

Standard motors are Class B rated for maximum temperature of 130°C.

*Unipolar drive gives approximately 30% less thrust vs. bipolar drive.

Travel Selection

Linear Travel/ Step	0.013	0.0254	0.051	0.102	0.203
Step Angle 7.5°					
Part No (X)	3	1	2	4	8
Linear Travel/Step	0.102	0.203	0.406		
Step Angle 15°					
Part No (X)	4	8	G		



All dimensions in mm

Actuators

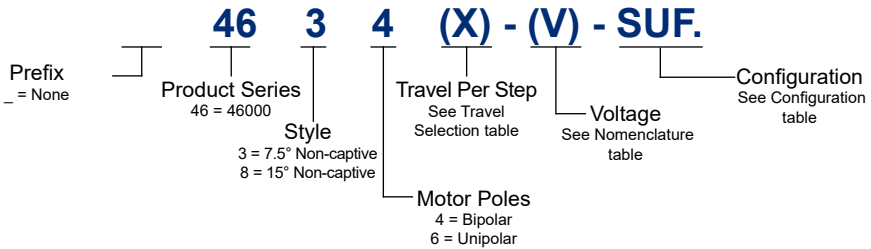
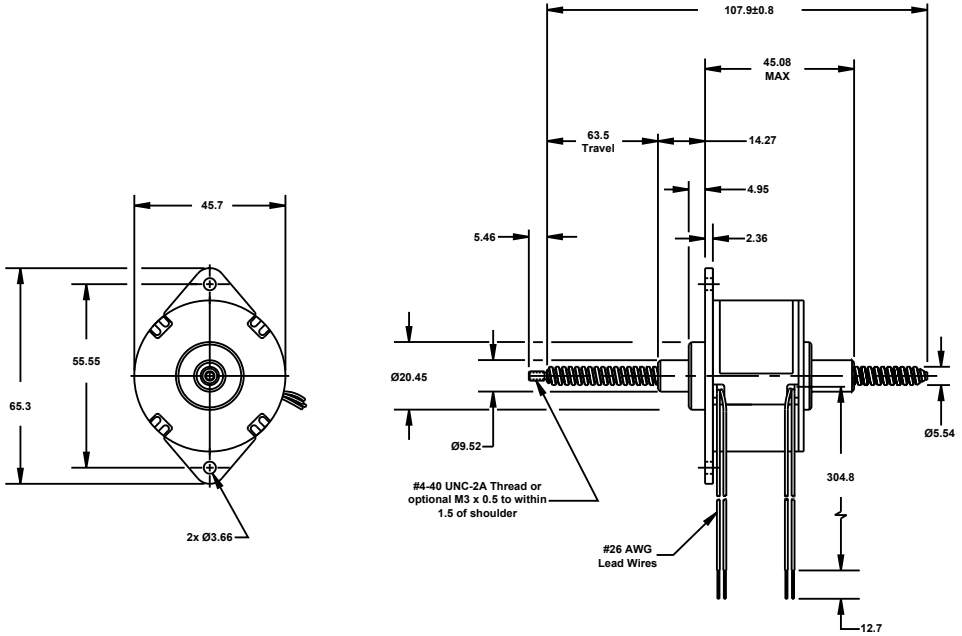

Technical Support

- Selection Guide : Page 1-01
- Product Overview : Page 1-144
- Performance curves : Page 1-244





Nomenclature

Ø46 mm Can-Stack Linear Actuator									
Part No.	Non-captive (3)	4634X-V-SUF		4684X-V-SUF		4636X-V-SUF		4686X-V-SUF	
Wiring		Bipolar (4 poles)				Unipolar* (6 poles)			
Step Angle		7.5° (4)		15° (5)		7.5° (4)		15° (5)	
Winding Voltage (V)		5 VDC	12 VDC	5 VDC	12 VDC	5 VDC	12 VDC	5 VDC	12 VDC
Current (RMS)/ Phase		1.0A	0.41A	1.0 A	0.41A	1.0A	0.41A	1.0 A	0.41A
Resistance/ Phase		5 Ω	29 Ω	51 Ω	29 Ω	5 Ω	29 Ω	51 Ω	29 Ω
Inductance/ Phase		9 mH	52mH	7.1 mH	39mH	4.5 mH	26 mH	3.5 mH	20 mH

Motor Specification

Ø46 mm Can-Stack Linear Actuator	
Power consumption	10 W Total
Rotor Inertia	25 gcm ²
Insulation Class	Class B
Weight	255g
Insulation Resistance	20MΩ

Standard motors are Class B rated for maximum temperature of 130°C.

*Unipolar drive gives approximately 30% less thrust vs. bipolar drive.

Travel Selection

Linear Travel/ Step	0.013	0.0254	0.051	0.102	0.203
Step Angle 7.5°					
Part No (X)	3	1	2	4	8
Linear Travel/Step	0.102	0.203	0.406		
Step Angle 15°					
Part No (X)	4	8	G		



All dimensions in mm

Actuators

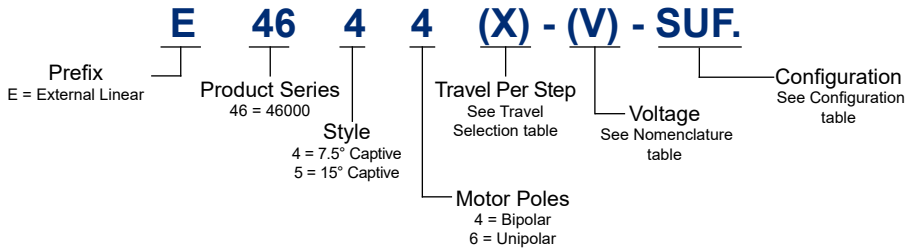
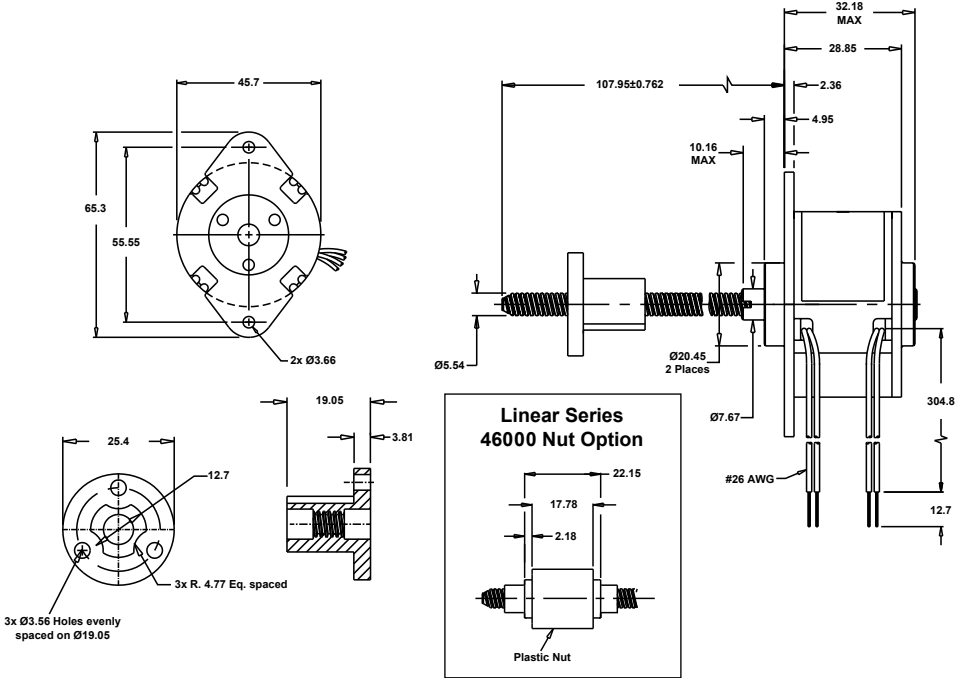

Technical Support

- Selection Guide : Page 1-01
- Product Overview : Page 1-144
- Performance curves : Page 1-244



Nomenclature

Ø46 mm Can-Stack Linear Actuator									
Part No.	External Linear (4)	E4644X-V-SUF		E4654X-V-SUF		E4646X-V-SUF		E4656X-V-SUF	
Wiring		Bipolar (4 poles)				Unipolar* (6 poles)			
Step Angle		7.5° (4)		15° (5)		7.5° (4)		15° (5)	
Winding Voltage (V)		5 VDC	12 VDC	5 VDC	12 VDC	5 VDC	12 VDC	5 VDC 12 VDC	
Current (RMS)/ Phase		1.0A	0.41A	1.0 A	0.41A	1.0A	0.41A	1.0 A 0.41A	
Resistance/ Phase		5 Ω	29 Ω	51 Ω	29 Ω	5 Ω	29 Ω	51 Ω 29 Ω	
Inductance/ Phase		9 mH	52mH	7.1 mH	39mH	4.5 mH	26 mH	3.5 mH 20 mH	

Motor Specification

Ø46 mm Can-Stack Linear Actuator	
Power consumption	10 W Total
Rotor Inertia	25 gcm ²
Insulation Class	Class B
Weight	255g
Insulation Resistance	20MΩ

Standard motors are Class B rated for maximum temperature of 130°C.

*Unipolar drive gives approximately 30% less thrust vs. bipolar drive.

Travel Selection

Linear Travel/ Step	0.013	0.0254	0.051	0.102	0.203
Step Angle 7.5°					
Part No (X)	3	1	2	4	8
Linear Travel/Step	0.102	0.203	0.406		
Step Angle 15°					
Part No (X)	4	8	G		



All dimensions in mm

This series is available with a NEMA mounting flange which is fitted as an adapter between the motor and the mating component.

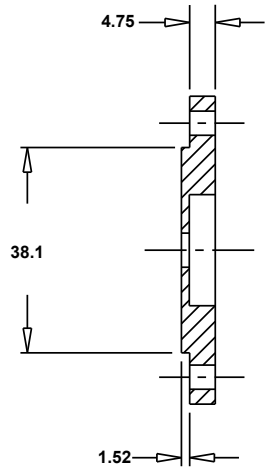
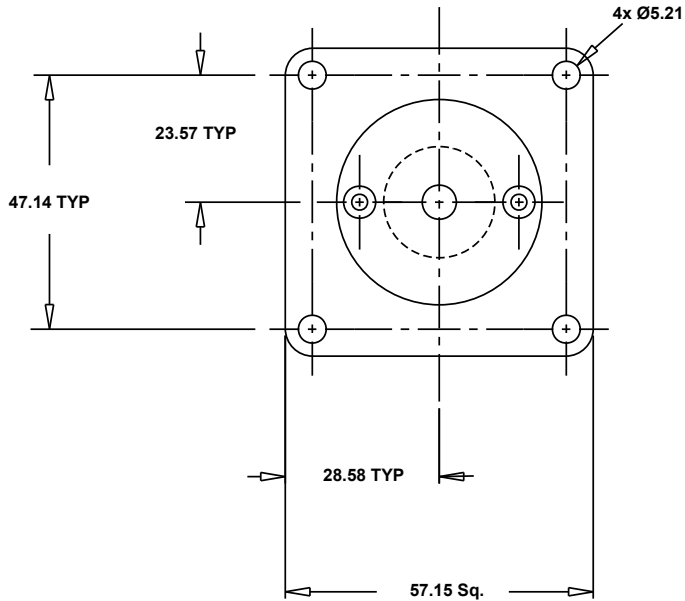

Actuators



Force vs. Pulse Rate Bipolar. L/R Drive. 100% Duty Cycle

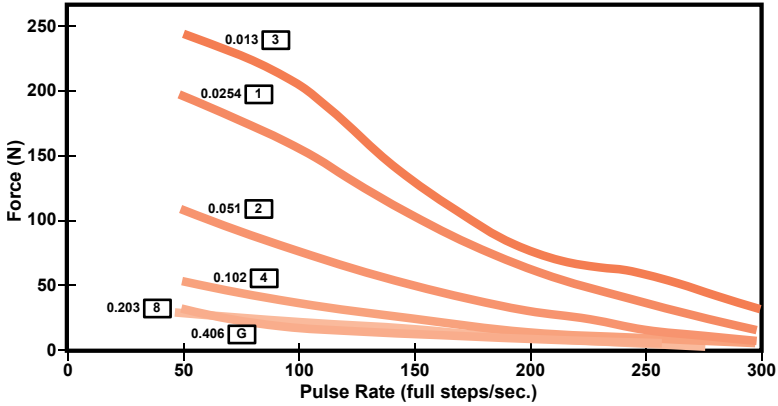

Force vs. Pulse Rate Bipolar. L/R Drive. 25% Duty Cycle

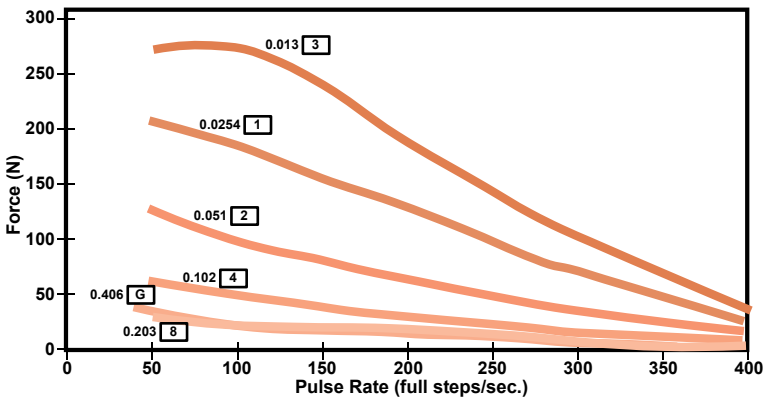

Actuators



Actuators

Force vs. Pulse Rate Bipolar. Chopper. 100% Duty Cycle

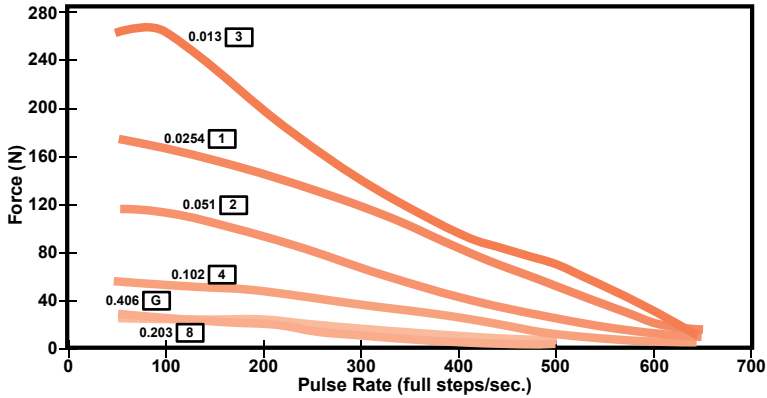

Force vs. Pulse Rate Bipolar. Chopper. 25% Duty Cycle

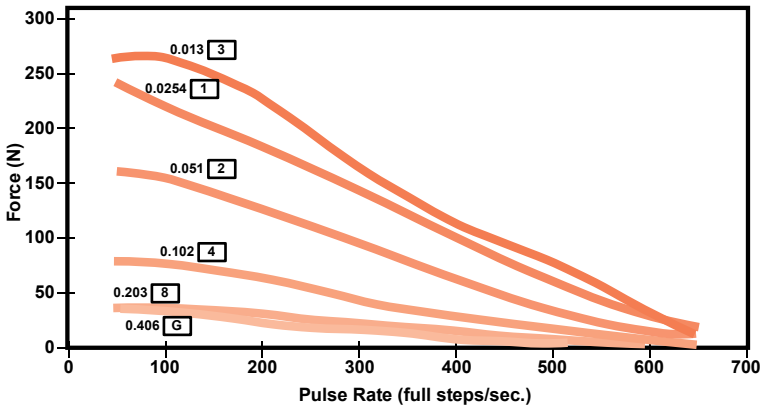

Note: All chopper drive curves were created with a 5 Volt motor and a 40 Volt power supply

Ramping can increase the performance of a motor either by increasing the top speed or getting heavier load accelerated up to speed faster. Also, deceleration can be used to stop the motor without overshoot.



Specially engineered can-stack linear actuators for high temperature applications

A line of stepping motors specially designed for high temperature environments, constructed using proven techniques and special materials which meet class F temperature ratings. Specialised components include high temperature bobbins coils, lead wires, lubricant and adhesives.

Actuators

20000 Series High Temperature Force vs Pulse Rate L/R Drive 100% Duty Cycle

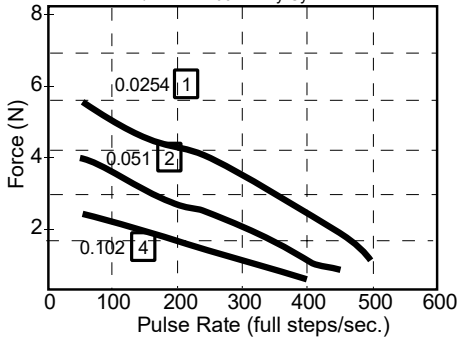

26000 Series High Temperature Force vs Pulse Rate L/R Drive 100% Duty Cycle

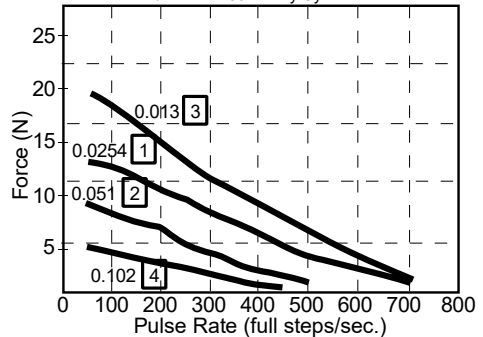

36000 Series High Temperature Force vs Pulse Rate L/R Drive 100% Duty Cycle

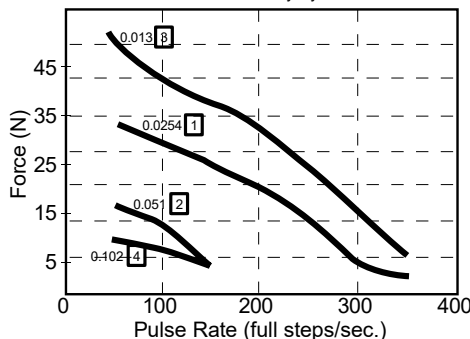



TFE coated leadscrews for applications that require a permanent, dry lubricant

The TFE coating allows for a greaseless screw and nut interface, so is ideal for applications where conventional oils and greases cannot be used. A non-lubricated TFE coated lead screw offers improved performance in both life and load capacity. The coating can be applied to a wide variety of lead screw pitches and is available for captive, non-captive and external linear actuators. Typical applications include medical equipment, laboratory instrumentation and applications where contamination from grease or lubricants must be avoided, such as silicon wafer handling and clean room assembly.

TFE 26000 Series - P/N T26542
Force vs Pulse Rate
L/R Drive 100% Duty Cycle

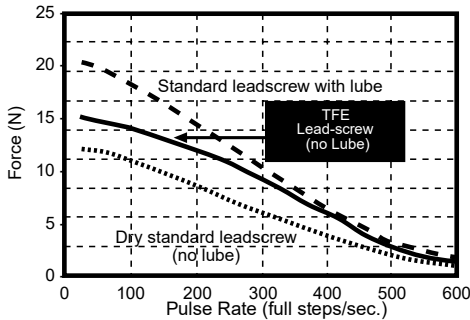

TFE 36000 - P/N T36441
Force vs Pulse Rate
L/R Drive 100% Cycle

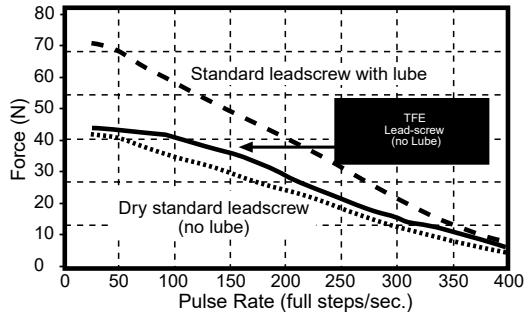



Home Position Switch

A miniature electronic home position switch capable of monitoring the home positions of linear actuators. The switch mounts on the rear sleeve of captive linear motors and allows the user to identify start, stop or home positions. Contacts can be normally open or normally closed. The contact closure is repeatable to within one step position, identifying linear movements as low as 0.0133mm per step. Multiple contact switches are also available.

The switch allow device manufacturers the ability to monitor movements more precisely for greater control and improved Q.C. When ordering motors with the home position switch, the part number should be preceded by an "S".



Actuators

Technical data

Contact Rating (standard): 1.00 AMP @ 120 VAC
1.00 AMP @ 28 VDC

Operating Temperature: -30°C TO +55°C

Contact Resistance: < 20 milliohms typ. initial at 2-4 V DC, 100mA

Electrical Life: Tested to 60,000 make-and-break cycles at full load

Schematic:

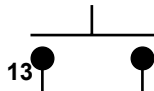

Multiple contact options available.



End of Stroke Proximity Sensor

The sensor incorporates a hall effect device, which is activated by a rare earth magnet embedded in the end of the internal screw. The compact profile of the sensor allows for installation in limited space applications.

The sensor has virtually unlimited cycle life. Special cabling and connectors can also be provided.

Technical data

Supply Voltage:	3.8min. to 24max
Current Consumption:	10mA max.
Output Voltage (Operated):	0.15 typ., 0.40 max.; Sinking 20mA max.
Output Current:	20mA max.
Output leakage current (released):	10µA max. @Vout = 24 VDC; Vcc = 24VDC
Output switching time:	
Rise, 10 to 90%:	.05µ typ., 1.5µs max. @ Vcc = 12V, RL = 1.6 KOhm
Fall, 90% to 10%:	.15µ typ., 1.5µs max. @ 20 pF

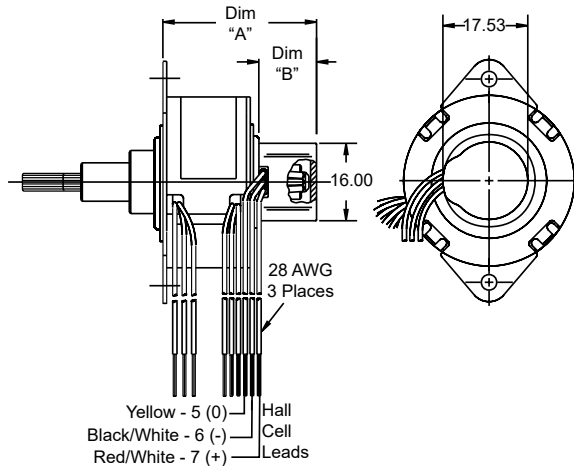
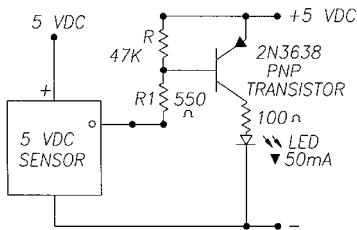

Note: Sensor is category 2 ESD sensitive per DOD-STD-1686A. Assembly operations should be performed at workstations with conductive tops and operators grounded.

Series	Dim "A"	Dim "B"
P36000	31.0	12.0
P26000	24.13	9.4
P20000	28.45	12.0

Actuators



Section contents

Programmable Stepper Motor Drive	Page 2-2
Brushless Motor Controller	Page 2-10
Drives for Stepper Motors	Page 2-14



The IDEA™ Drive Stepper Motor Controller



A stepper motor drive and fully programmable control unit that uses a Graphic User Interface. The IDEA Drive is available as an external programmable drive and controller, or integrated with a linear actuator to form a complete package of motor, actuator, and programmable drive.

Features include:

- RoHS Compliant
- Stand-alone unit or integrated with linear actuators / rail systems
- Programming done through Graphic User Interface
- Automatic population of motor and drive parameters
- Programmable Speed / Current / Accel-Decel / Current Boost / Interrupts / I/O
- Encoder Input / Stall Detection with Compensation / Position Verification
- USB or RS-485 Communication protocols
- Movement profile plotter
- Interactive program debug feature



IDEA™ Drive Part Number	PCM4806E	PCM4826E	ACM4806E	ACM4826E
Drive Input Voltage Range	12 to 48 VDC	12 to 48 VDC	12 to 48 VDC	12 to 48 VDC
Max Drive Current/Phase	0.6 A rms	2.6 A rms	0.6 A rms	2.6 A rms
Current Boost Capability	Optional 30% current boost capability during ramping			
Communication	USB (mini B)	USB (mini B)	RS-485	RS-485
Step Modes	Full, Half, 1/4, 1/8, 1/16, 1/32, 1/64			
Digital I/O Voltage Range	5 to 24 VDC			
Digital Inputs	4			
Digital Input Max Current	8 mA (each)			
Digital Outputs (Sinking)	4			
Digital Output Max Current (Sinking)	200 mA			
Maximum Temperature	70° measured at heat sink			
Program Storage Size	85 Kbytes			
Program Storage Memory Type	Flash			
Maximum Number Stored Programs	85 - referenced by 10 character program names			
Position Counter Range	64 bit			
Ramping	Trapezoidal			
Interrupt Sources	4 inputs (rising, falling or both edges) Internal Position counter (When reaching a programmed position)			
Max. # Drives per Communication Bus	1	1	225	225

Accessories	PART No.
USB Cable (A to mini B), 2 metres	56-1346
Power Cable, 1 metre	56-1348
I/O cable, 1 metre	56-1352
RS-485 Cable, 1 metre	56-1536-4
Encoder Cable, 0.3 metre	56-1715
Software Installation Disk	55-010
Motor Connector Assembly	56-1453
USB to RS-485 Adapter	UTR4852



IDEA™ Drive Software is simple to use with on-screen buttons and easy to understand programming guides

The software program generates motion profiles directly into the system and also contains a "debug" utility allowing line by line execution of a motion program for easy troubleshooting.



TYPICAL I/O INPUT (FOR PINS 3 – 6)

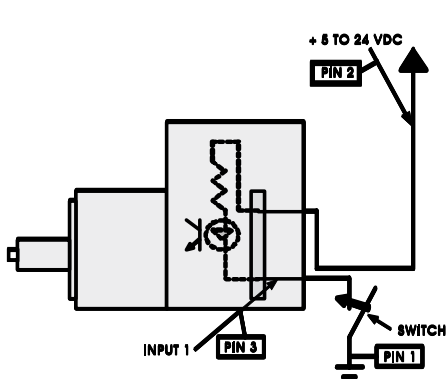

TYPICAL I/O OUTPUT (FOR PINS 7 – 10)

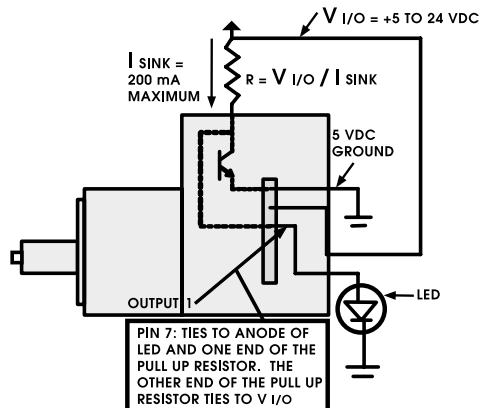



PCM4806E and PCM4826E IDEA™ Drive Engineering Drawings

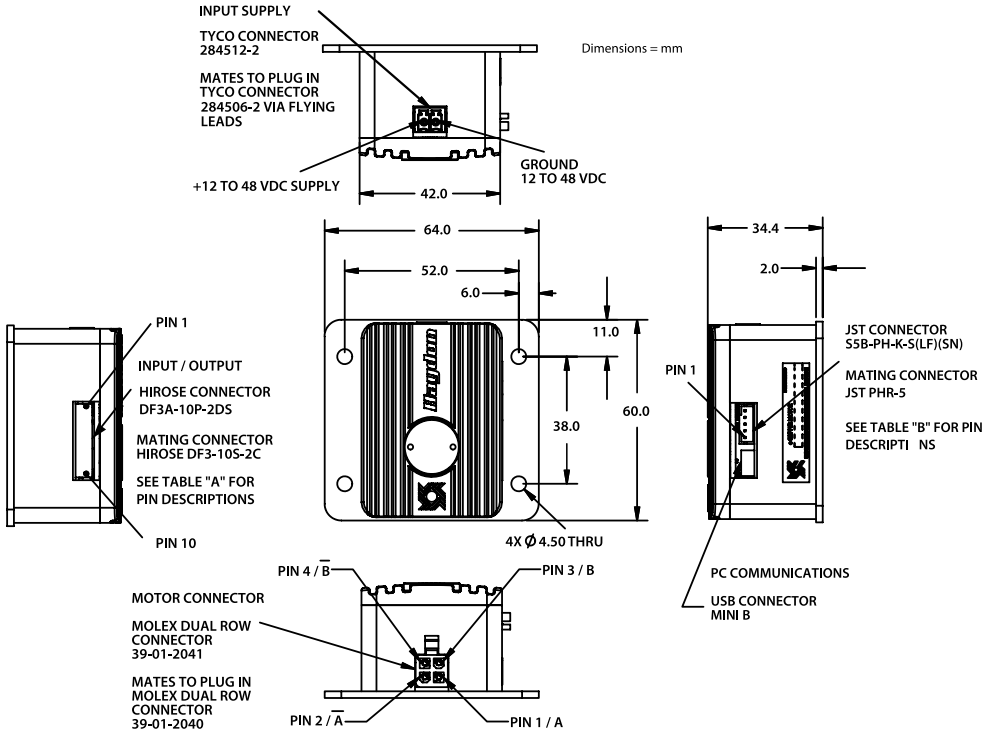

Table "A"

Pin Position	Description	Notes
Pin 1	Ground I/O Supply	5 to 24 VDC
Pin 2	+ I/O Supply	5 to 24 VDC
Pin 3	Input 1	
Pin 4	Input 2	
Pin 5	Input 3	
Pin 6	Input 4	
Pin 7	Output 1	
Pin 8	Output 2	
Pin 9	Output 3	
Pin 10	Output 4	

Table "B"

Pin #	Description
1	+5V
2	Ground
3	Index/ No connection
4	"B" Channel
5	"A" Channel



ACM4806E and ACM4826E IDEA™ Drive Engineering Drawings

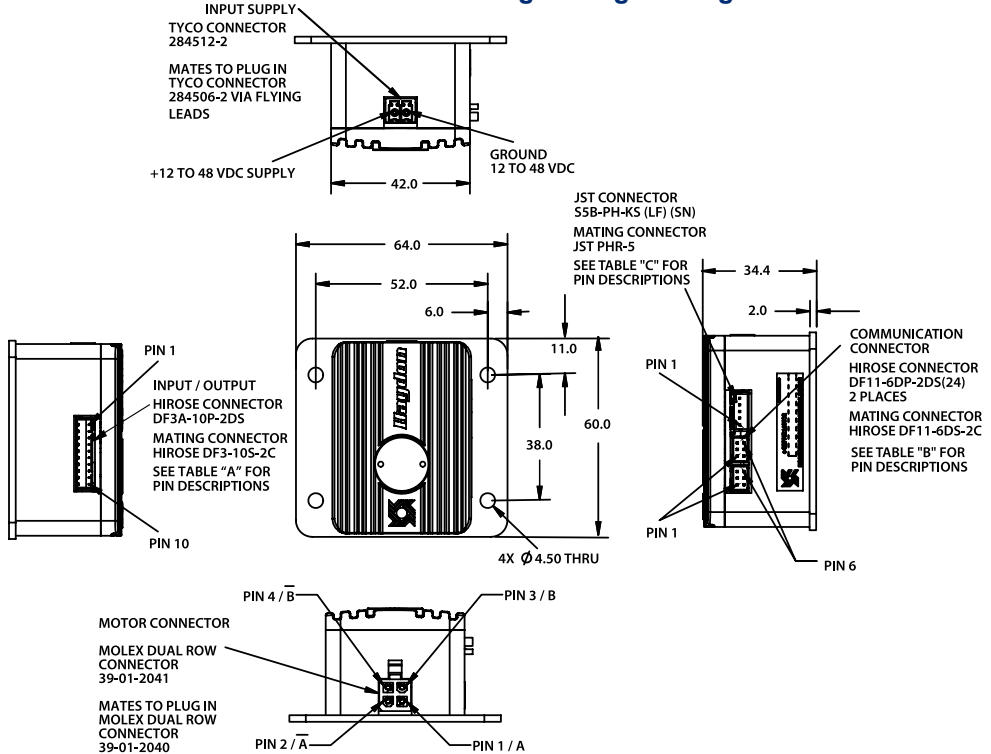

Table "A"

Pin Position	Description	Notes
Pin 1	Ground I/O Supply	5 to 24 VDC
Pin 2	+ I/O Supply	5 to 24 VDC
Pin 3	Input 1	
Pin 4	Input 2	
Pin 5	Input 3	
Pin 6	Input 4	
Pin 7	Output 1	
Pin 8	Output 2	
Pin 9	Output 3	
Pin 10	Output 4	

Table "B"

Pin #	Description
1	Y / Non-inverting driver output
2	Z / Inverting driver output
3	Ground
4	Ground
5	A / Non-inverting receiver input
6	B / Inverting receiver input

Table "C"

Pin #	Description
1	+5V
2	Ground
3	Index/ No connection
4	"B" Channel
5	"A" Channel



DCM4826X IDEA™ Drive



The DCM4826 IDEA Stepper Motor Drive is ideal for controlling both rotary stepper motors and stepper motor based linear actuator systems using a simple “pulse”, “direction”, and “enable” signal from a stepper motor control board. Input voltage to the drive is 12–48 VDC. The stepper motor drive can provide a load current of 2.6 A rms per phase. The PDE signals are optically isolated from the rest of the drive providing the ability to reference a separate electrical ground.



Attribute	Value
Drive Input Voltage Range	12 to 48 VDC
Max Drive Current / Phase	2.6 A rms
Step Modes	Full, Half, 1/4, 1/8, 1/16, 1/32, 1/64
Communicates	RS-485
Digital Input Voltage Range	0 to 24 VDC
Digital Input Maximum Current	35 mA (each)
Digital Input Maximum Pulse Width	5 µs
Maximum Pulse Input Frequency (0.5 V Square Wave)	100 Khz
Maximum Temperature	70° (Measured at heat sink)
RS-485 Cable, 1 metre	56-1536-4
Motor Connector Assembly	56-1453
USB to RS-485 Adapter	UTR4852



DCM4826X IDEA™ Drive

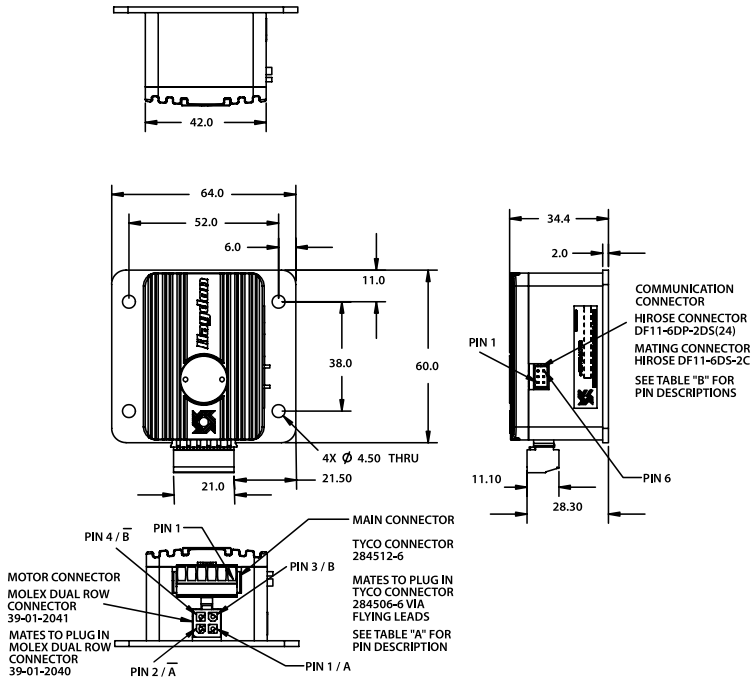

Table "A"

Pin Position	Description
Pin 1	Optoground
Pin 2	Enable
Pin 3	Direction
Pin 4	Pulse
Pin 5	Ground
Pin 6	+5 to 24 VDC

Table "B"

Pin #	Description
1	Y / Non-inverting Driver Output
2	Z / Inverting Driver Output
3	Ground
4	Ground
5	A / Non-inverting Receiver Input
6	B / Inverting Receiver Input



The IDEA™ Drive Brushless Motor Controller

The IDEA™ Drive Brushless Motor Controller is a servo drive and fully programmable control unit which has an intuitive Graphic User Interface removes the complexity of programming while support tools simplify its quick integration.

Features Include:

- RoHS Compliant
- Stand-alone drive unit
- Programming done though Graphic User Interface (GUI)
- Automatic population of motor and drive parameters
- Programmable Speed / Current / Accel-Decel / Current Boost / Interrupts / I/O
- Sinusoidal and S-Curve motion profiles
- USB Communication protocol
- Movement Program Debug feature
- Optional motor cables



Accessories	PART No.
USB Cable (A to mini B), 2 metres	56-1346
Power Cable, 1 metre	56-1348
I/O cable, 1 metre	56-1352
Motor Connector Screw Terminal	56-1570
Hall Cell & Encoder Cable	56-1856

Drives & Controllers

IDEA™ Drive Part Number	PBL4850E
Drive Input Voltage Range	12 to 48 VDC
Max Drive Current/Phase	4.0 A rms/ 6.5 A peak
Current Boost Capability	Optional 30% current boost capability during ramping (6.5 A peak max.)
Communication	USB (mini B)
Commutation	Sinusoidal (Hall and encoders required)
Motor	3 Phase Brushless
Hall cell spacing	60° / 120°
Encoder (min Requirement)	5V, Incremental encoders with 128 CPR min.
Digital I/O Voltage Range	5 to 24 VDC
Digital Input	4
Digital Input Max Current	8 mA (each)
Digital Outputs (Sinking)	4
Digital Outputs Max Current (Sinking)	200 mA
Maximum Temperature	70° measured at heat sink
Program Storage Size	85 Kbytes
Program Storage Memory Type	Flash
Maximum Number Stored Programs	85 - referenced by 10 character program names
Position Counter Range	64 bit
Ramping	Trapezoidal 0r S-Curve
Interrupt Sources	4 Inputs (rising, falling or both edges) Internal Position Counter (When reaching a programmed position)



IDEA™ Drive Software is simple to use with on-screen buttons and easy to understand programming guides

Common user interface between stepper and brushless drives allow our users to seamlessly transition across motor technologies.

Start performing moves with a brushless motor after entering a few motor characteristics. The graphical user interface is designed with the end user in mind, automatically calculating and populating motion parameters to speed up the development process. The interface can be set to units of inches, millimeters and revolutions to allow users to easily integrate the drive into linear or rotary based systems. The software program generates motion profiles directly into the system and also contains a "debug" utility allowing line by line execution of a motion profile for easy troubleshooting.

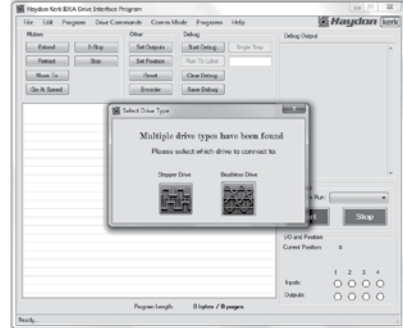
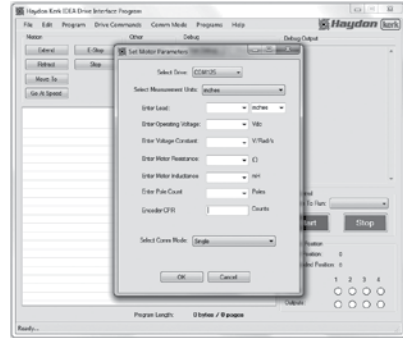

TYPICAL I/O INPUT (FOR PINS 3 - 6)

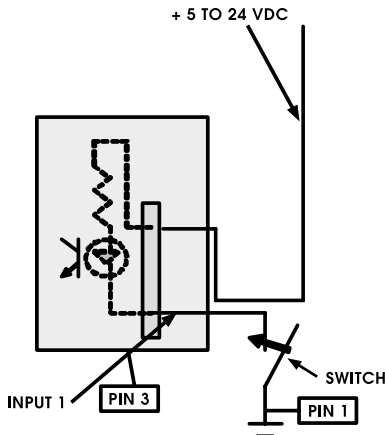

TYPICAL I/O OUTPUT (FOR PINS 7 - 10)

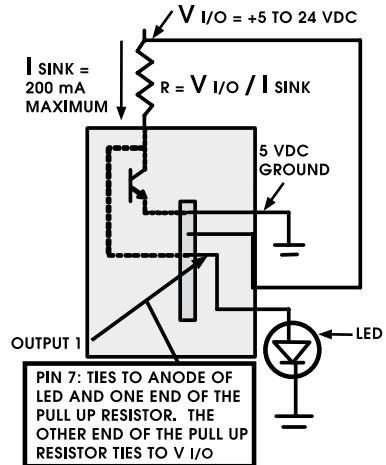



PBL4850E IDEA™ Engineering Drawings

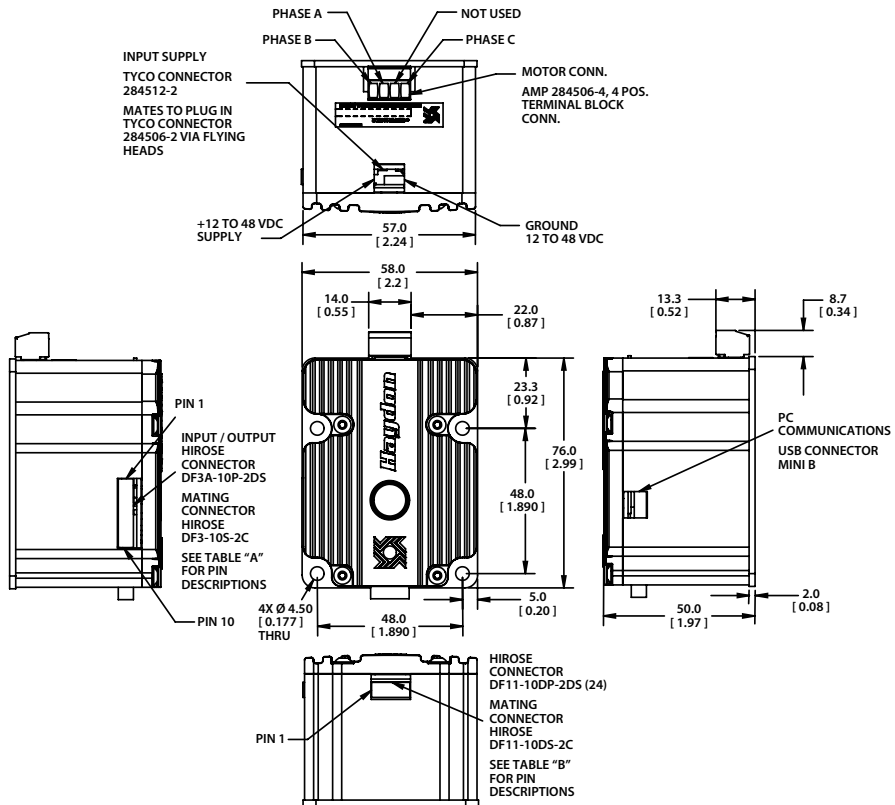

Table "A"

Pin Position	Description	Notes
Pin 1	Ground I/O Supply	5 to 24 VDC
Pin 2	+ I/O Supply	5 to 24 VDC
Pin 3	Input 1	
Pin 4	Input 2	
Pin 5	Input 3	
Pin 6	Input 4	
Pin 7	Output 1	
Pin 8	Output 2	
Pin 9	Output 3	
Pin 10	Output 4	

Table "B"

Pin #	Description
1	"A" Channel
2	Hall Cell A
3	"B" Channel
4	Hall Cell B
5	Index/ Encoder
6	Hall Cell C
7	+ 5V cc
8	+ 5V cc
9	Ground
10	Ground



Micro Stepping Drives DCM8027 & DCM8054

The DCM8027 and DCM8054 provide a cost effective solution for production volume requirements, the small size allow use in limited space and they are also easily integrated with other electronic systems. They are suitable for driving 2-Phase step motors (Maximum current ratings of 2.8 A and 5.5 A rms per phase). By using a bipolar constant-current chopping technique, and a maximum input voltage of 70 VDC, they can produce more speed and power from the same motor, compared with traditional technologies such as L/R drives.

The DCM8027 and DCM8054 feature micro step resolution from 1/2 step to 1/256. Fourteen micro step resolutions selectable in decimal and binary. The output current levels and micro step resolutions are easily set via the 8 bit DIP switch. These drivers are suitable for 4, 6 and 8 lead motors.



Drive DCM8027 & DCM8054 Drive Features

- User friendly chopper drive
- Input voltage range 20 to 70 VDC
- Suitable for 4, 6 and 8 lead motors
- Inaudible 20 khz chopping frequency
- TTL compatible and optically isolated input signals
- 14 selectable microstep resolutions in decimal and binary
- Current up to 5.5 A rms/phase
- Automatic idle current reduction

Micro Stepping Drives DCM8027 & DCM8054 Technical Data

Size:	97mm x 119mm x 48mm
Power requirement:	+20 - 70 VDC
Output current:	Adjustable from 5.5 A/Ø to 2.8 A/Ø RMS
Input pulse frequency:	200 KHz
Micro-stepping capability :	Between 400 and 50000 depending on DIP switch positions selected



Bipolar Chopper Drive DCS4020

DCS4020 Chopper Drive delivers optimum performance through a wide speed range. The DCS4020 is ideal for development projects where a single power supply will run the motor. The motor current is set using an on-board potentiometer and no external current setting resistors are required.

The DCS provides all the basic motor controls including full or half-stepping of bipolar steppers, directional control, and output enable control. An oscillator circuit is standard on the drive with an on-board speed control potentiometer. In addition, external input/output signals allow complete remote control of all drive functions. All electrical connectors have removable plugs incorporating screw type terminals.



Bipolar Chopper Drive DCS4020 Features

- On-board or external step pulse clock
- On-board or external single step switch
- On-board or external step rate control potentiometer
- On-board or external direction control
- On-board or external full step / half step control
- On-board or external enable control
- On-board current control potentiometer

Bipolar Chopper Drive DCS4020 Technical Data

Size:	85.85mm x 113.54mm x 33.27mm
Power requirement:	+24 - 40 VDC
Output current:	Adjustable 66mA/Ø to 2A/Ø RMS
Input pulse frequency:	2 KHz
Micro-stepping capability :	Full Step - 2 Phases On plus Half stepping



Whisper™ Drive 44103

A compact, micro-stepping drive for bipolar stepper motors that provides a cost effective solution for production volumes. The Whisper incorporates micro-stepping technology, a controller and runs off a single power supply. With eight micro-steps per full step, the Whisper can smooth out cogging often associated with Can-Stack steppers and the drive has a mixed current decay mode for reduced resonance and improved micro-stepping reduce audible noise in the motor.







Whisper™ Drive 44103 Features

- Bipolar chopper / constant current technology
- Automatic mixed current decay
- Selectable step: FULL, 1/2, 1/4, 1/8 step
- Use single power supply for motor and drive
- Step inhibit control
- Physically compact

Whisper™ Drive 44103 Technical Data

Size:	67.31 mm X 64.77 mm X 21.84 mm
Power requirement:	Regulated, 24 VDC to 28 VDC power supply
Output current:	Up to 1 A rms/Ø
Required motor coil voltage:	Bipolar, 5 VDC
External step pulse range:	Up to 8000 PPS for 1000 full steps/sec
Stepping:	Up to 8 microsteps per full step



	Introduction to Reliance	i-6
	Linear Actuators	1-1
	Hybrid Linear Actuators	1-26
	Can-Stack Linear Actuators	1-144
	Drives & Controllers	2-001



Rowley Mills, Penistone Road, Lepton
Huddersfield, HD8 0LE, England

+44 (0) 1484 601002
www.reliance.co.uk
sales@reliance.co.uk